

**TM 9-1345-203-12**

---

**TECHNICAL MANUAL**

**OPERATOR'S AND UNIT MAINTENANCE MANUAL**

**FOR**

**LAND MINES**

DISTRIBUTION STATEMENT A - Approved for public release; distribution is unlimited.

**HEADQUARTERS, DEPARTMENT OF THE ARMY**

---

**30 OCTOBER 1995**

## WARNING SUMMARY

Position mine so that friendly troops to rear and side of mine will not be endangered. Firing position should be at least 16 meters to rear or sides of mine.

Mine M18A1 will be prepared for non-electric detonation if there is a possibility of spontaneous initiation during electric storms which could endanger friendly troops. Keep friendly troops away from blast. Refer to FM 5-250.

Assure that face of mine marked "FRONT TOWARD ENEMY" and arrow on top of mine point in direction of enemy.

Mine firing position should be located in a cleared foxhole, a shielded or protected position, or at least 16 meters behind or to side of emplaced mine.

Care must be taken during emplacement of mines to secure firing device so that mine will not be dislodged by a pull of detonating cord or tripwire. If mine becomes dislodged thereby affecting aiming, it will be aimed in a direction other than intended.

A dislodged or overturned mine is a potential hazard to friendly personnel and should not be fired.

If taut wires are encountered when attempting to neutralize mine, do not cut wires under any circumstances. Attach long rope or wire to mine without disturbing taut tripwire; then, from an unmined protected position, remove mine cautiously - mine may detonate - by pulling rope or wire. If this method is not practical, refer matter to specially trained personnel.

Wear gloves and safety glasses or goggles when cutting strapping from pallets. Avoid being struck by ends of straps when tension is released.

To prevent injury, release tension on wooden boxes by pressing down on top of box while cutting straps on side of box.

Primers (for mine fuze) will be cleaned only with rags dampened with alcohol or acetone.

Avoid improper handling of mines. It may prove hazardous to personnel and impair reliability and safety of materials.

### **Mine, Antipersonnel: M86, Pursuit Deterrent Munition (PDM)**

Once arming strap is lifted, deployment is mandatory. Do not attempt to resafe.

Safe separation time is 25 seconds after strap is lifted. **Leave area immediately after employment and do not return to area.**

The M86 mine has a self-destruct feature which makes it expendable; therefore, do **not** return to area.

Do not deploy mine below -25°F. If mine is deployed below -25°F, mine may self-destruct either in a 5-minute timeframe or later than the programmed self-destruct timeframe.

**Do not remove nose protector or nose protector tape.** Removal of tape may damage the electromagnetic radiation (EMR) and the electrostatic discharge (ESD) protective paints.

If one or more triplines are found deployed **prior** to use, **do not** arm or attempt to use the PDM. Turn in mine for disposal.

## **WARNING SUMMARY - Continued**

### **Mine, Antitank, Training: M80 with Fuze Mine, M606 Inert**

The dimensions are identical with the live mine and the inert mine. Care must be exercised not to use live components in the inert mine.

### **Mine, Antipersonnel: M16 Series (M16, M16A1, M16A1 Inert, M16A2) with Fuze, Mine Antipersonnel: M605**

Mine, antipersonnel, M16A1 inert is a completely inert mine without any explosive components. It is used for training purposes only. The dimensions are identical with the live mine and the inert mine. Care must be exercised not to use any live components with the inert mine.

When handling the M605 fuze, always take care to avoid pushing on the circular depression in the body of the fuze opposite the tripwire pulling boss. This is the slider holding the firing pin and any movement (even the small amount allowed with the safety cotter pin in place) can place the firing pin closer to the point of release.

When arming the M605 fuze, always pull the positive safety pin with fingers (rather than just pulling on the string) to avoid imparting the shock to the fuze which could actuate it.

Do not attempt to neutralize a damaged mine. Either destroy it in place with prepared charge, or attach 50-meter length of wire or rope to head of fuze and, from secure protected position, pull mine from hole. Destroy mine by detonating remotely in a safe area.

### **Mine, Antipersonnel: M18A1, with Electric Initiation System**

A continuity test of firing circuit should be conducted before blasting cap is placed into detonator well.

Operator will retain possession of M57 firing device at all times during laying of mine and testing of firing circuit. This prevents accidental firing by a second individual.

Firing device should not be connected to the firing wire until the actual time of firing.

Before connecting blasting cap to firing device, safety bail must be in "SAFE" position and all personnel who are within 250 meters of front and sides of mine and 100 meters of rear of mine must be under cover.

The M57 firing device may not be safe if handle is depressed or sustains a sharp impact, even with bail up in "SAFE" position, when it is connected to the firing circuit. Movement of handle can produce electrical energy and premature mine detonation. This effect may be intermittent and it varies between and among M57 lots.

Before replacing blasting cap, disconnect firing wire from test set and reinstall shorting plug in test set and at end of firing wire.

**Mine, Antipersonnel: M18A1, with Non-Electric Initiation System**

Operator will retain possession of the shock tube initiator at all times during setting up the mine and unspooling the shock tube. This prevents accidental firing by a second individual.

There is a possibility of hot gaseous by-products being released from the igniter forward end opening (shock tube insertion point) when initiating the munition. During firing of the igniter, keep hands clear of this area.

Do not ingest or inhale explosive powder in shock tube. After handling shock tube, wash hands before eating or drinking.

If initiation of the M18A1 fails, wait 30 minutes before approaching munition.

**Mine, Antipersonnel, Practice: M8, with Fuze, Mine Combination, Practice: M10 or M10A1; Mine Antipersonnel, Practice: M8A1, and Fuze, Mine Combination, Practice: M10A2**

Use extreme care when handling mine M8. It contains a spotting charge assembly which can be dangerous to personnel who are not under cover.

Mine M8 contains a cap, projectile, and spotting charge. When the mine functions, the cap, projectile, and spotting charge are propelled upward. Mine M8A1 has a plug which is propelled upward. Personnel should be away from mines and under cover to avoid being struck by falling parts.

**Mine, Antipersonnel, Practice: M68**

Use practice blasting cap M10 only with mine M68. Do not use M6, M7, or any other live cap with it. No substitutions are allowed.

**Mine, Antitank: HE, Heavy, M15, with Fuze, Mine, AT, M603 and Activator, AT, Mine: M1 or with Fuze, Mine: M624**

Do not carry this mine by the handle. The handle may open up and the mine will fall off.

The M624 fuze cannot be deployed by the M57 antitank mine dispenser or by any other mechanical means. The dispenser will initiate the M624 fuze.

When removing safety pin, **carefully** pull and slide out while laying in the prone position. Once armed, do **not** touch or apply pressure to the extension rod! A minimum horizontal force of 3.75 pounds (small force) at the end of extension rod, or a minimum horizontal force of 45 pounds on the side of the pressure ring will initiate fuze. Carefully follow instructions and figures in procedures.

Do not mistake chemical mine for a mine M15. The mine M23 is similar in size and shape to the mine M15. The chemical mine can be distinguished visually and by touch from the mine M15 by eight raised projections spaced in pairs around the periphery of the top of the chemical mine.

**Mine, Antitank: HE, Nonmetallic (NM): M19, with Fuze, Mine, M606**

Mines may have drifted downstream and/or contain antipersonnel or antihandling devices. Removal by methods other than explosive breaching (TM 9-1375-213-12) is extremely hazardous and is not recommended. If the situation demands such recover, proceed with utmost caution.

**WARNING SUMMARY - Continued**

**Mine, Antitank: HE, M24, with Fuze M404**

In positioning peepsight on launcher, keep hands and arms clear of launcher ends.

In all handling and sighting operations, remain clear of rear and front of launcher. Sight with body stretched at right angles to launcher.

Do not attempt testing after rocket cable assembly is connected to firing device.

When mine system is fully armed, it will fire when pressure is applied to discriminator. Stand clear of front and rear of launcher.

CHANGE )  
          )  
NO. 4

HEADQUARTERS  
DEPARTMENT OF THE ARMY  
WASHINGTON, DC, 24 October 2006

**Operator's and Unit Maintenance Manual  
for  
Land Mines**

DISTRIBUTION STATEMENT A - Approved for public release; distribution in unlimited.

TM 9-1345-203-12, 30 October 1995, is changed as follows:

1. File this change sheet after the Warning Summary for reference purposes.
2. Remove old pages and insert new pages as indicated below.
3. New or changed material is indicated by a vertical bar in the outer margin of the page.
4. Added or revised illustrations are indicated by a vertical bar adjacent to the illustration identification number.
5. Added or revised appendixes are indicated by a vertical bar adjacent to the appendix title.
6. This change also implements the Army Maintenance Transformation and changes the Maintenance Allocation Chart (MAC) to support Field and Sustainment Maintenance.
7. Front Cover reprinted due to moving the Warnings on inside cover to a Warning Summary.

Remove Pages

None  
A and B  
i thru vi  
1-1 thru 1-4  
1-7 and 1-8  
1-11 and 1-12  
1-19 thru 1-26  
2-5 thru 2-8  
2-11 thru 2-18  
2-21 thru 2-26  
None  
2-33 and 2-34  
2-49 and 2-50  
2-73 and 2-74  
5-1 and 5-2  
A-1 and A-2  
C-1 thru C-6  
DA Form 2028-2  
Front Cover

Insert Pages

a thru d  
A and B  
i thru vi  
1-1 thru 1-4  
1-7 and 1-8  
1-11 and 1-12  
1-19 thru 1-26  
2-5 thru 2-8  
2-11 thru 2-18  
2-21 thru 2-26  
2-26.1 thru 2-26.10  
2-33 and 2-34  
2-49 and 2-50  
2-73 and 2-74  
5-1 and 5-2  
A-1 and A-2  
C-1 thru C-26  
DA Form 2028  
Front Cover

By Order of the Secretary of the Army:

Official:

  
JOYCE E. MORROW

Administrative Assistant to the  
Secretary of the Army

0613804

PETER J. SCHOOMAKER  
General, United States Army  
Chief of Staff

DISTRIBUTION: To be distributed in accordance with the initial distribution number (IDN) 400950 requirements for TM 9-1345-203-12.

CHANGE  
NO. 3

HEADQUARTERS  
DEPARTMENT OF THE ARMY  
Washington, DC, 15 May 2002

**OPERATOR'S AND UNIT  
MAINTENANCE MANUAL  
FOR  
LAND MINES**

DISTRIBUTION STATEMENT A: Approved for public release; distribution is unlimited.

TM 9-1345-203-12, dated 30 October 1995, is changed as follows:

1. File this change sheet in front of the publication for reference purposes.
2. Remove old pages and insert new pages as indicated below.
3. New or changed material is indicated by a vertical bar in the margin of the page.
4. Added or revised illustrations are indicated by a vertical bar adjacent to the illustration identification number.
5. Added or revised appendixes are indicated by a vertical bar adjacent to the appendix title.

**Remove pages**

A and B  
i and ii  
2-33 and 2-34  
2-45 and 2-46  
3-5 and 3-6  
4-3 and 4-4  
4-7 and 4-8  
A-1 and A-2

**Insert pages**

A and B  
i and ii  
2-33 and 2-34  
2-45 and 2-46  
3-5 and 3-6  
4-3 and 4-4  
4-7 and 4-8  
A-1 and A-2

By Order of the Secretary of the Army:

Official:

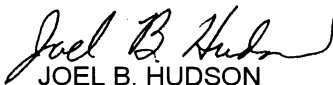
  
JOEL B. HUDSON  
Administrative Assistant to the  
Secretary of the Army

0211202

ERIC K. SHINSEKI  
General, United States Army  
Chief of Staff

Distribution:

To be distributed in accordance with IDN 400950, requirements for TM 9-1345-203-12.

CHANGE  
NO. 2

HEADQUARTERS  
DEPARTMENT OF THE ARMY  
Washington, DC, 30 September 1997

**OPERATOR'S AND UNIT MAINTENANCE MANUAL  
FOR  
LAND MINES**

DISTRIBUTION STATEMENT A: Approved for public release; distribution unlimited.

TM 9-1345-203-12, dated 30 October 1995, is changed as follows:

1. Cross out information on inside cover. The information is changed and placed on page a.
2. Remove old pages and insert new pages as indicated below. Changed material is indicated by a vertical bar in the margin of the page. Added or revised illustrations are indicated by a vertical bar adjacent to the identification number.

Remove pages

A and B  
i and ii  
2-1 and 2-2  
2-3 and 2-4

Insert pages

A and B  
i and ii  
2-1 and 2-2  
2-3 and 2-4

2. File this change sheet in front of the publication for reference purposes.

By Order of the Secretary of the Army:

DENNIS J. REIMER  
General, United States Army  
Chief of Staff

Official:

  
JOEL B. HUDSON

*Administrative Assistant to the  
Secretary of the Army*

04049

Distribution:

To be distributed in accordance with IDN 400950, with requirements for TM 9-1345-203-12.



CHANGE

HEADQUARTERS  
DEPARTMENT OF THE ARMY  
Washington, DC, 30 June 1997

NO. 1

**OPERATOR'S AND UNIT MAINTENANCE MANUAL  
FOR  
LAND MINES**

DISTRIBUTION STATEMENT A: Approved for public release; distribution unlimited.

TM 9-1345-203-12, dated 30 October 1995, is changed as follows:

1. Cross out information on inside cover. The information is changed and placed on page a.
2. Remove old pages and insert new pages as indicated below. Changed material is indicated by a vertical bar in the margin of the page. Added or revised illustrations are indicated by a vertical bar adjacent to the identification number.

Remove pages

A and B  
i and ii  
1-3 and 1-4  
1-21 and 1-22  
C-5 and C-6  
E-5 and E-6

Insert pages

A and B  
i and ii  
1-3 and 1-4  
1-21 and 1-22  
C-5 and C-6  
E-5 and E-6

2. File this change sheet in front of the publication for reference purposes.

By Order of the Secretary of the Army:

DENNIS J. REIMER  
General, United States Army  
Chief of Staff

Official:

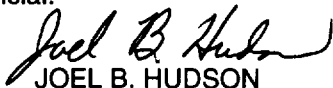
  
JOEL B. HUDSON

*Administrative Assistant to the  
Secretary of the Army*  
03788

Distribution:

To be distributed in accordance with IDN 400950, with requirements for TM 9-1345-203-12.

**LIST OF EFFECTIVE PAGES**

INSERT LATEST CHANGED PAGES. DESTROY SUPERSEDED PAGES.

NOTE The portion of the text affected by the changes is indicated by a vertical line in the outer margins of the page. Changes to illustrations are indicated by a vertical line adjacent to the identification number.

Dates of issue for original and changed pages are:

Original . . . . . 0 . . . . . 30 October 1995	Change . . . . . 3 . . . . . 15 May 2002
Change . . . . . 1 . . . . . 30 June 1997	Change . . . . . 4 . . . . . 24 October 2006
Change . . . . . 2 . . . . . 30 September 1997	

TOTAL NUMBER OF PAGES IN THIS PUBLICATION IS 184, CONSISTING OF THE FOLLOWING:

Page No.	*Change No.	Page No.	*Change No.	Page No.	*Change No.
Cover	0	4-5 thru 4-7	0		
Inside Cover	4	4-8	3		
a thru d	4	5-1 and 5-2	4		
A	4	A-1 and A-2	4		
B	0	B-1 thru B-4	0		
i thru vi	4	C-1 thru C-26	4		
1-1 thru 1-4	4	D-1 thru D-4	0		
1-5 and 1-6	0	E-1 thru E-4	0		
1-7	4	E-5	1		
1-8 thru 1-11	0	E-6	0		
1-12	4				
1-13 thru 1-18	0				
1-19 thru 1-25	4				
1-26	0				
2-1 thru 2-4	2				
2-5	0				
2-6 and 2-7	4				
2-8 thru 2-11	0				
2-12 thru 2-14	4				
2-15	0				
2-16 thru 2-18	4				
2-19 thru 2-21	0				
2-22 thru 2-25	4				
2-26	0				
2-26.1 thru 2-26.10	4				
2-27 thru 2-32	0				
2-33 and 2-34	4				
2-35 thru 2-44	0				
2-45	3				
2-46 thru 2-49	0				
2-50	4				
2-51 thru 2-72	0				
2-73	4				
2-74 thru 2-76	0				
3-1 thru 3-5	0				
3-6	3				
4-1 thru 4-3	0				
4-4	3				

\*Zero in this column indicates an original page

**THIS PAGE INTENTIONALLY LEFT BLANK**

**TECHNICAL MANUAL**

**No. 9-1345-203-12**

**HEADQUARTERS  
DEPARTMENT OF THE ARMY  
Washington, DC, 30 OCTOBER 1995**

**Operator's and Unit Maintenance Manual  
for  
Land Mines**

**REPORTING ERRORS AND RECOMMENDING IMPROVEMENTS**

You can help improve this manual. If you find any mistakes or if you know of a way to improve the procedures, please let us know. Mail your letter or DA Form 2028 (Recommended Changes to Publications and Blank Forms) located in the back of this manual directly to Logistics Research and Engineering Directorate (AMSRD-AAR-AIL-LS), U.S. Army RDECOM, Armament Research, Development and Engineering Center, Picatinny Arsenal, NJ 07806-5000. You may also send in your recommended changes via electronic mail or by fax. Our e-mail address is LSB@PICA.ARMY.MIL. Our fax number is DSN 880-4633, Commercial (973) 724-4633. A reply will be furnished to you.

	Page
CHAPTER I INTRODUCTION .....	1-1
Section I. GENERAL .....	1-1
1-1. Scope .....	1-1
1-2. Forms, Records, and Reports .....	1-1
1-3. Destruction of Army Materiel to Prevent Enemy Use .....	1-1
Section II. DESCRIPTION AND DATA .....	1-1
1-4. General .....	1-1
1-5. Mine, Antipersonnel: M14, with Integral Fuze .....	1-4
1-6. Mine, Antipersonnel: M16 Series (M16, M16A1, M16A1 Inert, M16A2) with Fuze, Mine Antipersonnel: M605 .....	1-4
1-7. Mine, Antipersonnel: M18A1 and Accessories Packed in Bandoleer M7 .....	1-6
1-8. Mine, Antipersonnel: M86, Pursuit Deterrent Munition (PDM) .....	1-10
1-9. Mine, Antipersonnel, Practice: M8, with Fuze, Mine Combination, Practice: M10 or M10A1; Mine, Antipersonnel, Practice: M8A1, with Fuze, Mine Combination, Practice: M10A2 .....	1-12
1-10. Mine, Antipersonnel, Practice: M68 .....	1-12
1-11. Mine, Antitank: HE, Heavy, M15, with Fuze, Mine, AT, M603 and Activator M1 or with Fuze, Mine: M624 .....	1-14
1-12. Mine, Antitank: HE, Nonmetallic (NM), M19, with Fuze, Mine, M606 .....	1-16
1-13. Mine, Antitank: HE, Heavy, M21, with Fuze, Mine, AT, M607 .....	1-17
1-14. Mine, Antitank: HE, M24, with Fuze M404 .....	1-18
1-15. Mine, Antitank, Practice: Heavy, M12A1 .....	1-20
1-16. Mine, Antitank, Practice: Heavy, M20 .....	1-20
1-17. Mine, Antitank, Training: M80 with Fuze Mine, M606 Inert .....	1-20
1-18. Canister, Mine: M87 and M87A1 .....	1-22
1-19. Canister, Mine, Practice: M88 .....	1-23
1-20. Canister, Mine, Practice: M89 .....	1-24
Section III. SAFETY, CARE, AND HANDLING .....	1-24
1-21. Safety .....	1-24
1-22. Care and Handling .....	1-25

CHAPTER 2	OPERATING INSTRUCTIONS . . . . .	2-1
	2-1. Mine, Antipersonnel: M14, with Integral Fuze . . . . .	2-1
	2-2. Mine, Antipersonnel: M16 Series (M16, M16A1, M16A1 Inert, M16A2) with Fuze, Mine, Antipersonnel: M605 . . . . .	2-6
	2-3. Mine, Antipersonnel: M18A1, with Electric Initiation System . . . . .	2-12
	2-3.1. Mine, Antipersonnel: M18A1, with Non-Electric Initiation System . . . . .	2-26.1
	2-4. Mine, Antipersonnel: M86 . . . . .	2-27
	2-5. Mine, Antipersonnel, Practice: M8, with Fuze, Mine Combination, Practice: M10 or M10A1: Mine, Antipersonnel, Practice: M8A1, and Fuze, Mine Combination, Practice: M10A2 . . . . .	2-32
	2-6. Mine, Antipersonnel, Practice: M68 . . . . .	2-33
	2-7. Mine, Antitank: HE, Heavy, M15, with Fuze, Mine, AT, M603 and Activator, AT, Mine: M1 or with Fuze, Mine: M624 . . . . .	2-34
	2-8. Mine, Antitank: HE, Nonmetallic (NM): M19, with Fuze, Mine, M606 . . . . .	2-47
	2-9. Mine, Antitank: HE, Heavy, M21, with Fuze, Mine, Combination, AT M607 . . . . .	2-56
	2-10. Mine, Antitank: HE, M24, with Fuze M404 . . . . .	2-61
	2-11. Mine, Antitank, Practice: Heavy, M21A1 and M20 . . . . .	2-73
CHAPTER 3	OPERATOR MAINTENANCE INSTRUCTIONS . . . . .	3-1
Section I.	SERVICE UPON RECEIPT OF MATERIEL . . . . .	3-1
	3-1. General . . . . .	3-1
	3-2. Unpacking Precautions . . . . .	3-1
Section II.	TOOLS AND EQUIPMENT . . . . .	3-6
	3-3. Common Tools and Equipment . . . . .	3-6
	3-4. Repair Parts and Special Tools . . . . .	3-6
Section III.	MAINTENANCE . . . . .	3-6
	3-5. General . . . . .	3-6
	3-6. Inspection . . . . .	3-6
	3-7. Cleaning/Preservation . . . . .	3-6
	3-8. Adjustment of Firing Device and Fuze Safety Pin . . . . .	3-6
	3-9. Inspection of Mine Canisters . . . . .	3-6
CHAPTER 4	UNIT MAINTENANCE INTRUCTIONS . . . . .	4-1
	4-1. General . . . . .	4-1
	4-2. Expendable Materials . . . . .	4-1
	4-3. Inspection of Packaging . . . . .	4-1
	4-4. Inspection of Mines and Mine Canisters . . . . .	4-3
	4-5. Cleaning, Touch-up, and Marking of Mines and Mine Canisters . . . . .	4-4
	4-6. Maintenance of Packaging Hardware . . . . .	4-5
	4-7. Maintenance of Packaging Containers and Materials . . . . .	4-6
	4-8. Marking of Packaging Material . . . . .	4-7
	4-9. Repacking Procedures . . . . .	4-7
	4-10. Painting and Marking of Boxes with Light Loads . . . . .	4-8

CHAPTER 5	SHIPMENT/MOVEMENT AND STORAGE . . . . .	5-1
Section I.	SHIPMENT/MOVEMENT . . . . .	5-1
	5-1. Precautions . . . . .	5-1
	5-2. Instructions . . . . .	5-1
	5-3. Data . . . . .	5-1
Section II.	STORAGE . . . . .	5-1
	5-4. Precautions . . . . .	5-1
	5-5. Data . . . . .	5-2
	5-6. Procedures . . . . .	5-2
APPENDIX A	REFERENCES . . . . .	A-1
APPENDIX B	PACKING MATERIALS, ACCESSORIES, AND TOOLS . . . . .	B-1
Section I.	INTRODUCTION . . . . .	B-1
Section II.	PACKING MATERIALS AND ACCESSORIES . . . . .	B-1
Section III.	SPECIAL PACKING TOOLS . . . . .	B-3
APPENDIX C	MAINTENANCE ALLOCATION CHART . . . . .	C-1
Section I.	INTRODUCTION . . . . .	C-1
Section II.	MAINTENANCE ALLOCATION CHART FOR LAND MINES . . . . .	C-3
APPENDIX D	EXPENDABLE AND DURABLE ITEMS LIST . . . . .	D-1
Section I.	INTRODUCTION . . . . .	D-1
Section II.	EXPENDABLE AND DURABLE ITEMS LIST . . . . .	D-2
APPENDIX E	PACKING, MARKING, AND STORAGE DATA . . . . .	E-1
Section I.	INTRODUCTION . . . . .	E-1
Section II.	PACKING, MARKING, AND STORAGE DATA . . . . .	E-1

## LIST OF ILLUSTRATIONS

Number	Title	Page
1-1	Mine, antipersonnel: M14, with integral fuze . . . . .	1-4
1-2	Mine, antipersonnel: M16A1 inert . . . . .	1-6
1-3	Mine, antipersonnel, training: M81 . . . . .	1-6
1-4	Mine, antipersonnel: M18A1 . . . . .	1-7
1-5	Mine, antipersonnel: M18A1 and accessories packed in bandoleer M7 . . . . .	1-9
1-6	Mine, antipersonnel: M86 . . . . .	1-11
1-7	Mine, antipersonnel: M86, packed two to a bandoleer . . . . .	1-11
1-8	Mine, antipersonnel, practice: M8, with fuze, mine combination, practice: M10 or M10A1 . . . . .	1-12
1-9	Mine, antipersonnel, practice, NM: M68 . . . . .	1-13
1-10	Mine, antitank: HE, heavy, M15, with fuze, mine, AT, M603 . . . . .	1-14
1-11	Mine, antitank: HE, heavy, M15, with fuze, mine M624 (ARMED) . . . . .	1-15
1-12	Mine, antitank: HE, NM, M19, with fuze, mine, M606 . . . . .	1-16

## LIST OF ILLUSTRATIONS - Continued

Number	Title	Page
1-13	Mine, antitank: HE, heavy, M21, with fuze, mine, AT, M607 . . . . .	1-17
1-14	Basic components, mine, AT: HE, M24 . . . . .	1-18
1-15	Emplaced mine, antitank: HE, M24 . . . . .	1-19
1-16	Mine, antitank, practice: heavy, M12A1 . . . . .	1-20
1-17	Mine, antitank, practice: heavy, M20 . . . . .	1-21
1-18	Mine, antitank, training: M80 with fuze, mine, M606 inert . . . . .	1-21
1-19	Canister, mine: M87 and M87A1 . . . . .	1-22
1-20	Canister, mine, practice: M88 . . . . .	1-23
1-21	Canister, mine, training: M89 . . . . .	1-24
2-1	Cutaway view of mine, antipersonnel: M14, with integral fuze . . . . .	2-1
2-2	Fuze wrench M22 (old and new styles) . . . . .	2-2
2-3	Mine M14 components . . . . .	2-3
2-4	Silicone grease G-697 being applied to joint between detonator holder and bottom of mine, AP, M14 . . . . .	2-4
2-5	Mine, antipersonnel: M16A1, with fuze, mine antipersonnel: M605, with tripwire and fuzing wrench M25 . . . . .	2-7
2-6	Applying silicone grease G-697 on mine M16A2 . . . . .	2-8
2-7	Installation of tripwire for mine M16A2 . . . . .	2-11
2-8	Mine, antipersonnel: M18A1, electric initiation system with accessories . . . . .	2-13
2-9	Casualty and danger areas of antipersonnel mine M18A1 with electric initiation system . . . . .	2-14
2-10	Aiming antipersonnel mine M18A1 with electric initiation system (equipped with knife-edge sight) . . . . .	2-17
2-11	Electric blasting cap assembly M4, with blasting cap M6 . . . . .	2-17
2-12	Mine M18A1 set up for nonelectric detonation . . . . .	2-19
2-12.1	Mine, antipersonnel: M18A1, with non-electric initiation system . . . . .	2-26.1
2-12.2	Casualty and danger areas of antipersonnel mine M18A1 with non-electric initiation system . . . . .	2-26.2
2-12.3	Aiming antipersonnel mine M8A1 with non-electric initiation system (equipped with knife-edge sight) . . . . .	2-26.4
2-12.4	Non-electric blasting cap assembly with factory crimped blasting cap and permanently attached shock tube igniter . . . . .	2-26.4
2-12.5	Mine M18A1 set up for non-electric detonation with shock tube . . . . .	2-26.8
2-13	Packing for mine, antipersonnel: M86 . . . . .	2-27
2-14	Packing (inner, intermediate, and outer) for mine, antipersonnel: M86 . . . . .	2-29
2-15	Arming sequence, mine, antipersonnel: M86 . . . . .	2-30
2-16	Mine, antipersonnel, practice: M8, with fuze, mine combination, practice: M10 or M10A1 . . . . .	2-33
2-17	Mine, antipersonnel, practice: M8A1, with fuze, mine combination, practice: M10A2 . . . . .	2-33
2-18	Packing box for two antipersonnel practice mines M8 and twenty of each replacement part . . . . .	2-33
2-19	Packing box for mine M15 and M624, fuze M603, and activator M1 . . . . .	2-34
2-20	Arming wrench M20 . . . . .	2-34
2-21	Fuze well . . . . .	2-35
2-22	Fuze M603 metal container . . . . .	2-35
2-23	Fuze, mine, AT, M603 . . . . .	2-35
2-24	Coating fuze M603 with silicone grease G-697 . . . . .	2-35
2-25	Setting knob in SAFE and ARMED positions . . . . .	2-36
2-26	Inserting M603 fuze and arming mine M15 . . . . .	2-36
2-27	Emplacing mine M15 . . . . .	2-37
2-28	Laying mine into pit . . . . .	2-37
2-29	Outer packing for M624 fuze . . . . .	2-38
2-30	Inner packing for M624 fuze . . . . .	2-39

2-31	Correct configuration of M624 fuze . . . . .	2-41
2-32	Wrong. Safety pin loop should be on right side . . . . .	2-41
2-33	Wrong. Safety pin left leg should not be assembled inside safety band . . . . .	2-41
2-34	Safety pin and M624 fuze greasing . . . . .	2-42
2-35	Unscrew and remove end closure . . . . .	2-42
2-36	Tighten fuze by hand . . . . .	2-42
2-37	Tighten fuze with extension rod . . . . .	2-42
2-38	Recommended burial for tilt rod fuze AT mines . . . . .	2-43
2-39	Extension rod assembly . . . . .	2-43
2-40	Assembly of extension rod into fuze ring . . . . .	2-43
2-41	Left hand grasping fuze (arming fuze) . . . . .	2-44
2-42	Pull with right hand (arming fuze) . . . . .	2-44
2-43	Removal of safety pin (arming fuze) . . . . .	2-44
2-44	Remove safety band and stop (fuze is armed) . . . . .	2-45
2-45	Antihandling devices . . . . .	2-45
2-46	One method of boobytrapping mine M15 . . . . .	2-45
2-47	Removing fuze M606 from fuze well of mine M19 . . . . .	2-48
2-48	Armed and unarmed firing pin in fuze M606 . . . . .	2-49
2-49	Depth of water chart for emplacement of mine M19 . . . . .	2-52
2-50	Stream and river emplacement of mines M19 . . . . .	2-53
2-51	Triangulation method of emplacing mines M19 in streams . . . . .	2-54
2-52	Outriggers for amphibious emplacement of mines M19 . . . . .	2-55
2-53	Cutaway view of mine, antitank: M21 . . . . .	2-56
2-54	Wirebound packing box for mine, antitank: M21 and components . . . . .	2-57
2-55	Removal of closure assembly from fuze M607 . . . . .	2-58
2-56	Arming wrench M26 . . . . .	2-59
2-57	Band, stop, and pull ring assembly in place . . . . .	2-59
2-58	Accessories pouch fastened to dispenser pouch (mine M24) . . . . .	2-61
2-59	Discriminator spool with accessories compartment cover removed (mine M24) . . . . .	2-62
2-60	Demolition firing device M61 . . . . .	2-63
2-61	Unreeling discriminator . . . . .	2-63
2-62	Emplacement for wheeled and tracked vehicles . . . . .	2-64
2-63	Connecting discriminator to firing device . . . . .	2-66
2-64	Preferred launcher placement . . . . .	2-67
2-65	Launcher with cable assembly attached to rocket . . . . .	2-67
2-66	Emplaced launcher and sighting assembly, weighted . . . . .	2-68
2-67	Safety band in place and removed . . . . .	2-69
2-68	Depressing ejection pin . . . . .	2-69
2-69	Exposed shorting clip . . . . .	2-69
2-70	Launcher with bipod assembly and elevation and azimuth sighting assembly . . . . .	2-70
2-71	Emplaced launcher and sighting assembly with bipod - weighted . . . . .	2-72
3-1	Typical wirebound box . . . . .	3-1
3-2	Sallee closer . . . . .	3-2
3-3	Typical fiber containers . . . . .	3-3
3-4	Ammunition metal container . . . . .	3-4
3-5	Mine Canister metal container . . . . .	3-5



## LIST OF TABLES

Number	Title	Page
1-1	Mines, Miscellaneous Components, and Mine Canisters.....	1-1
1-2	Service Mines, Mine Canisters, and Practice Counterparts. ....	1-3
3-1	Defective Material - Operator Level .....	3-6
4-1	Inspection Criteria for Packaging .....	4-1
4-2	Inspection Criteria for Mines and Fuzes .....	4-3
4-3	Inspection Criteria for Mine Canisters. ....	4-4
5-1	Quantity-Distance Data for Field Storage Category E. ....	5-2

# CHAPTER 1 INTRODUCTION

## Section I. GENERAL

### 1-1. Scope

These instructions are for use by operator and unit maintenance personnel. Refer to FM 20-32 for emplacement techniques and tactical requirements of land mine warfare.

reported in DA Form 285 (Accident Report) in accordance with AR 385-40. Explosive ammunition malfunctions will be reported in accordance with AR 75-1.

### 1-2. Forms, Records, and Reports

Department of the Army maintenance forms and reporting procedures are prescribed in DA Pam 750-8. Accidents involving injury to personnel or damage to materiel will be

### 1-3. Destruction of Army Materiel to Prevent Enemy Use

Destruction of land mines subject to capture or abandonment will be undertaken by the user only when such action is indicated by orders of, or policy established by, the Army commander (see TM 43-0002-33).

## Section II. DESCRIPTION AND DATA

### 1-4. General

a. Land mines covered in this manual are listed in table 1-1. Included are fuzes, miscellaneous components, and mine canisters.

(2) Practice mines are generally duplicates of service mines. They are used for training purposes and may contain a small black powder or pyrotechnic charge to give a puff of smoke or a noise to simulate functioning of the mine.

b. Land mines and related components are classified under service or practice categories (tables 1-1 and 1-2).

(3) Inert mines are usually metal or plastic counterparts of the service mines, but they contain no explosive element. They are used for training with inert material, such as sand, to simulate the weight of the service mine.

(1) Service mines contain high explosive charges. They are the primary tactical munitions.

c. Service mines and mine canisters, with their practice counterparts, are listed in table 1-2.

Table 1-1. Mines, Miscellaneous Components, and Mine Canisters .

Nomenclature	Color Identification	National Stock Number (NSN)	Department of Defense Identification Code (DODIC)
<b>ANTIPERSONNEL</b>			
<b>SERVICE</b>			
Mine, Antipersonnel: M14, with Integral Fuze	Olive Drab Yellow Lettering	1345-00-096-3093	K121
Mine, Antipersonnel: M16 Series (M16, M16A1, M16A1 Inert, M16A2) with Fuze, Mine Antipersonnel: M605	Olive Drab Yellow Lettering	1345-00-965-0742 1345-00-799-7391	K092
Mine, Antipersonnel: M18A1, Electric Initiation	Olive Drab Yellow Lettering	1345-00-710-6946 1345-00-926-3950	K143 K145 (Limited access)
Mine, Antipersonnel: M18A1, Non-Electric Initiation with Accessories	Olive Drab Yellow Lettering	1345-01-526-6440	J007
Mine, Antipersonnel: M26, with Integral Fuze	Olive Drab Yellow Lettering	1345-00-678-9822	K146
Mine, Antipersonnel: M86, Pursuit Deterrent Munition (PDM)	Olive Drab Yellow Lettering	1345-01-243-5089	K152

Table 1-1. Mines, Miscellaneous Components, and Mine Canisters - Continued.

Nomenclature	Color Identification	National Stock Number (NSN)	Department of Defense Identification Code (DODIC)
ANTIPERSONNEL - Continued			
PRACTICE			
Mine, Antipersonnel, Practice: M8, with Fuze, Mine Combination, Practice: M10 or M10A1; Mine, Antipersonnel, Practice: M8A1, with Fuze, Mine Combination, Practice: M10A2	Blue White Lettering Brown Band	1345-00-028-5092 1345-00-555-5870	K105
Mine, Antipersonnel, Practice: M68 Inert Mini Det Assembly	Blue Bronze	1345-00-402-2226 1375-01-529-4258	K139 MP04
Mine, Antipersonnel, Training: M81	Bronze White Lettering	6920-01-136-3628	
ANTITANK			
SERVICE			
Mine, Antitank: HE, Heavy, M15 with Fuze, Mine, AT, M603	Olive Drab Yellow Lettering	1345-00-028-5118 1345-00-173-2715	K180
Mine, Antitank: HE, NM, M19, with Fuze, Mine, M606	Olive Drab Yellow Lettering	1345-00-348-8646 1345-00-849-9768	K250
Mine, Antitank: HE, Heavy, M21, with Fuze, Mine Combination, AT, M607	Olive Drab Yellow Lettering	1345-00-729-4263 1345-00-173-2716	K181
Mine, Antitank: HE, M24, with Fuze, M404	Olive Drab Yellow Lettering	1345-00-782-5513	K182
PRACTICE			
Mine, Antitank, Practice: Heavy, M12A1	Blue, White Lettering	1345-00-028-5117	K230
Mine, Antitank, Practice: Heavy, M20	Blue, White Lettering	1345-00-344-2368	K231
Mine, Antitank, Training: M80 with Fuze, Mine, M606 Inert	Olive Drab with Bronze Circles White Lettering	1345-00-799-7390	K242
MISCELLANEOUS COMPONENTS			
Activator, Antitank, Mine: M1	N/A	1345-00-028-5124	K001
Activator, Antitank, Mine: Practice, M1	Black Body, Blue Cap	1345-00-028-5105	K002
Activator, Antitank, Mine: M2	Olive Drab Yellow Lettering	1345-00-324-1424	K003
Arming, Plug, Antitank Mine: M4	Olive Drab	1345-00-028-5115	K273
Body, Antipersonnel, Mine: For Practice, AP, Mine, M8A1	Blue, White Lettering Brown Band	1345-00-665-3955	K280
Cap, Antipersonnel, Mine: For Mine, AP, Practice: M8	Blue	1345-00-028-5126	M271
Charge, Spotting, Mine: For Mine, AP, Practice: M8	N/A	1345-00-028-5127	K040
Firing Device, AP Mine: M57, For Use with Mine, AP M18A1	Olive Drab	1345-00-070-1010	K008
Fuze, Mine: M10A1	Olive Drab	1345-00-028-5121	K055
Mine Antipersonnel: M2A4	No Color, Metallic	1345-00-028-5076	K090
Fuze, Mine: M604	Blue, White Lettering	1345-00-028-5130	K051
Fuze, Mine, M624	M607 Fuze Olive Drab Adapter Anodized Black Yellow Lettering	1345-01-228-8477	K068
Fuze, Mine: M605	Olive Drab Yellow Lettering	1345-00-965-0694	M058

Table 1-1. Mines, Miscellaneous Components, and Mine Canisters - Continued.

Nomenclature	Color Identification	National Stock Number (NSN)	Department of Defense Identification Code (DODIC)
Primer, Ignite, Mine Fuze: For Fuze, Mine Combination: M10A1	N/A	1345-00-028-5128 1345-00-965-0550	K030 K031
Retainer, Antitank Mine Booster: For Booster M120	Metallic	1345-00-077-2203 1345-00-028-5107	K274
Simulator, Antipersonnel Mine, Projectile: For Mine, AP: Practice, M8	N/A	1345-00-028-5123	K270
Test Set: M40, For Use with Mine, AP: M18A1	Olive Drab	4925-00-073-5159	N/A
MINE CANISTERS			
Canister, Mine: M87	Green, Yellow Band	1345-01-233-2029	K045
Canister, Mine: M87A1	Green, Yellow Band	1345-01-384-3617	J003
Canister, Mine, Practice: M88	Light Blue, Brown and Blue Bands	1345-01-233-2030	K042
Canister, Mine, Training: M89	Blue	1345-01-333-0298	

Table 1-2. Service Mines, Mine Canisters, and Practice Counterparts.

Service Mine	Practice Counterpart
<p>Antipersonnel</p> <p>M14, AP, NM, with Integral Fuze</p> <p>M16 Series (M16, M16A1, M16A2), AP, with Fuze, Mine Combination: M605</p> <p>M18A1, AP, with Accessories</p> <p>M18A1, AP, Non-Electric</p> <p>M26, AP, with Integral Fuze</p> <p>Antitank</p> <p>M15, AT, HE, Heavy, with Fuze, Mine, AT, M603 or with Fuze, Mine: M624</p> <p>M19, AT, HE, NM, with Fuze, Mine M606</p> <p>M21, AT, HE, Heavy, with Fuze, Mine, AT, M607</p> <p>M24, AT, HE, with Fuze M404</p> <p>Service Mine Canister</p> <p>Canister, Mine: M87</p> <p>Canister, Mine: M87A2</p>	<p>None</p> <p>M8 Series (M8, M8A1), AP, Practice and Fuze, Mine Combinations: M10/M10A1/M10A2 and Mine AP M16A1 Inert</p> <p>M68, AP, Practice, with Accessories</p> <p>M35, AP, Practice (not in production)</p> <p>M12A1, AT, Practice, Heavy with Fuze M604</p> <p>M20, AT, Practice with Fuze M604</p> <p>M80, Mine, AT, Training</p> <p>None</p> <p>None</p> <p>Practice Counterpart</p> <p>Canister, Mine, Practice: M88</p> <p>Canister, Mine, Training: M89</p>

**1-5. Mine, Antipersonnel: M14, with Integral Fuze**

a. *Description.*

(1) This blast-type, high-explosive mine (fig. 1-1) has a cylindrical, all-plastic body. Six external body ribs provide strength and identify the mine in the dark. Pressure plate, slotted for insertion of steel U-shaped safety clip, has a yellow indicating arrow and is indented to accommodate mine and fuze wrench M22. Letters A and S on top of the fuze body signify Armed and Safe, respectively.

(2) A force of 20 to 35 pounds is needed to depress pressure plate which, in turn, depresses the belleville spring. The belleville spring snaps into reverse, driving firing pin into detonator M46; the detonator explodes main charge of 1 ounce of tetryl.

b. *Use.* Because it is small, the mine can be used in large numbers and may be readily concealed. Mine is capable of inflicting serious casualties, since it explodes upon direct contact. Because of its all-plastic construction (except for metal firing pin), it is difficult to detect by mine detectors.

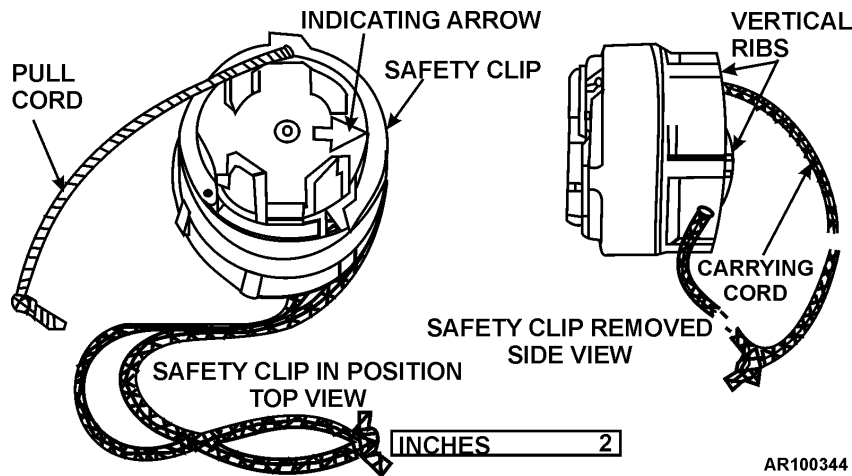

Figure 1-1. Mine, antipersonnel: M14 with integral fuze.

**1-6. Mine, Antipersonnel: M16 Series (M16, M16A1, M16A1 Inert, M16A2) with Fuze, Mine Antipersonnel: M605**

a. *Description.*

(1) These mines are a bounding, fragmentation-type, consisting of a antipersonnel mine fuze, M605, a propelling charge, and a projectile, all contained in a cylindrical, sheet steel case. A fuze screws through the top of the case into the fuze well, which extends through the projectile to the bottom of the case where the propelling charge is located. The mine is operated by pressure or a tripwire attached to release pin ring of fuze. The different models differ mainly in the inner construction of detonators and boosters.

(2) Pressure of 8 to 45 pounds acting on one or more of the three prongs of the fuze or pull of 3 to 15 pounds on a tripwire attached to the release pin ring of the fuze causes release of firing pin which then strikes the primer. Primer initiates delay which, in turn, initiates igniter charge; igniter transmits flame to propelling charge and propelling charge initiates delay charges and expels the projectile from mine. Delay charges in projectile then cause detonator, booster, and bursting charge to function, bursting the shell at a height of approximately 0.3 - 1.7 meters.

b. *Use.* Mine is highly effective. Primarily, it is employed in mixed mine fields to protect antitank mines against enemy breaching parties. It can be used in preparation of ambushes or nuisance mining of areas likely to be occupied by enemy troops and in hasty protective mine-fields.

**THIS PAGE INTENTIONALLY LEFT BLANK**

(1) The M16A1 inert mine (fig. 1-2) is used for training and handling only. It contains no explosive components and uses the M605 inert fuze.

(2) The M81 training mine (fig. 1-3) is used for training and handling only. It has the same configuration as the M16A2 AP Mine, contains no explosive components and uses the M605 inert fuze.

**1-7. Mine, Antipersonnel: M18A1 and Accessories Packed in Bandoleer M7**

*a. Description.*

(1) Mine (fig. 1-4) is a curved, rectangular, olive-drab, molded case of fiberglass-filled polystyrene (plastic) containing several hundred steel balls and high explosive, C4. The inside of the front face is lined with the steel balls, embedded in a plastic matrix, in back of which (behind matrix) is the layer of C4 explosive. The fragmentation face is convex (toward enemy) to direct the fragments in a 60° arc. A built-in sight and two pairs of scissors-type folding legs allow aiming of mine. It functions effectively in temperatures of -40° to 125°F and after having been submerged in salt water or fresh water for 2 hours.

(a) Two detonator wells located on top of mine enable it to be fired from two locations electrically or by nonelectric, single, or dual priming. Plug ends of shipping plug priming adapters seal wells, preventing entry of foreign matter. Slotted end of shipping plug priming adapter holds an electric or nonelectric lasting cap in place when mine is armed.

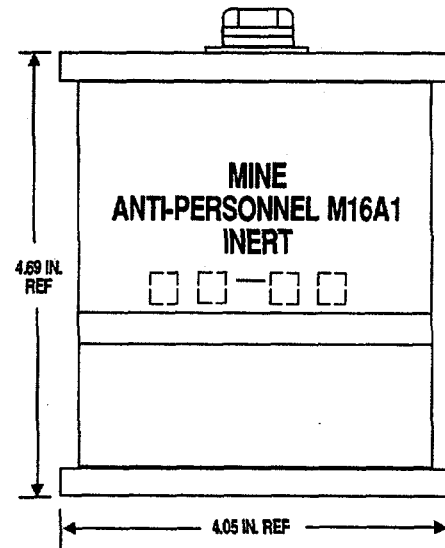

U  
AR 101909-A

**Figure 1-2. Mine, antipersonnel: M16A1 inert.**

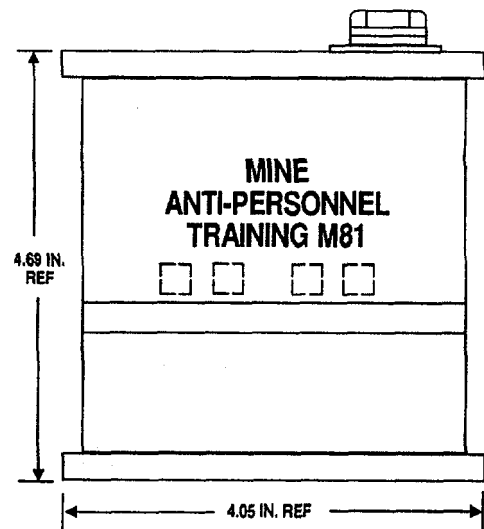

U  
AR 6376

**Figure 1-3. Mine, antipersonnel, training: M81.**

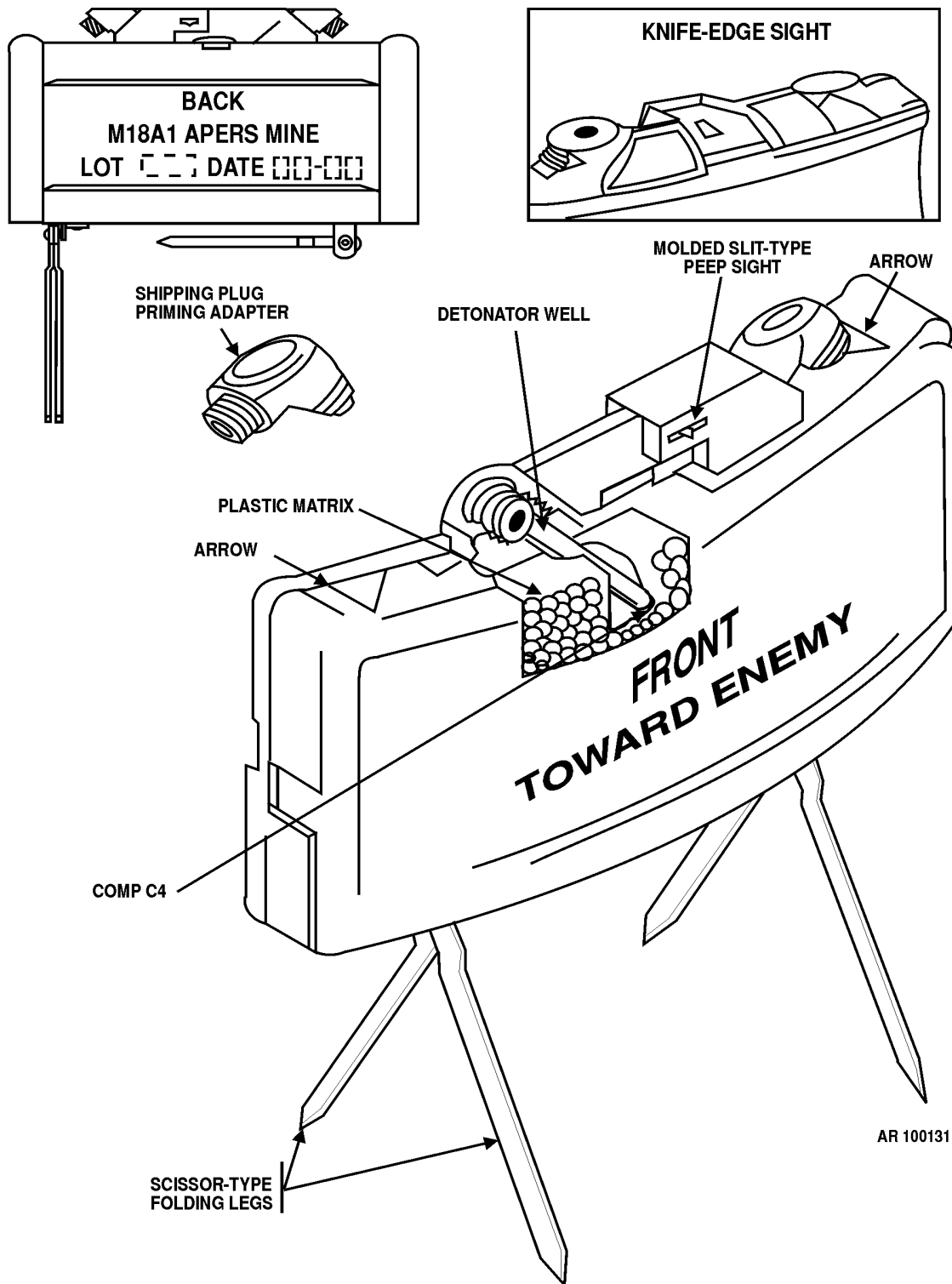

Figure 1-4. Mine, antipersonnel: M18A1.



**NOTE**

Shipping plug-priming adapter is reversed when mine is to be armed.

(b) The molded, knife-edge sight on later models (slit-type peep-sight on old model(s)) is used to aim mine.

(c) Two pairs of folding legs make possible the emplacement of mine on all types of surfaces. Mine can also be tied to posts, trees, etc.

(2) The accessories of the mine (fig. 1-5) consist of a firing device M57, and hand-held pulse generator, test set M40 (used for checking continuity of mine firing circuit), and an electric blasting cap assembly M4, which initiates main charge of mine. The blasting cap assembly M4 con-

sists of an electric blasting cap M6, and 100 feet of firing wire terminating in an electrical connector and shorting plug.

(3) When mine M18A1 (fig. 1-4) has been armed, actuation of firing device handle (safety bail in armed position) produces an electrical pulse that will detonate blasting cap. The detonation of the blasting cap, in turn, detonates mine high explosive charge (comp C-4). Detonation of high explosive charge propels steel balls in mine toward the enemy in a fan-shaped pattern.

b. *Use.* Mine is of a directional, fixed, fragmentation-type, used primarily for defense of bivouac areas, outposts, and against infiltration tactics. It is also effective against such thin-skinned vehicles as jeeps, automobiles, trucks, etc.

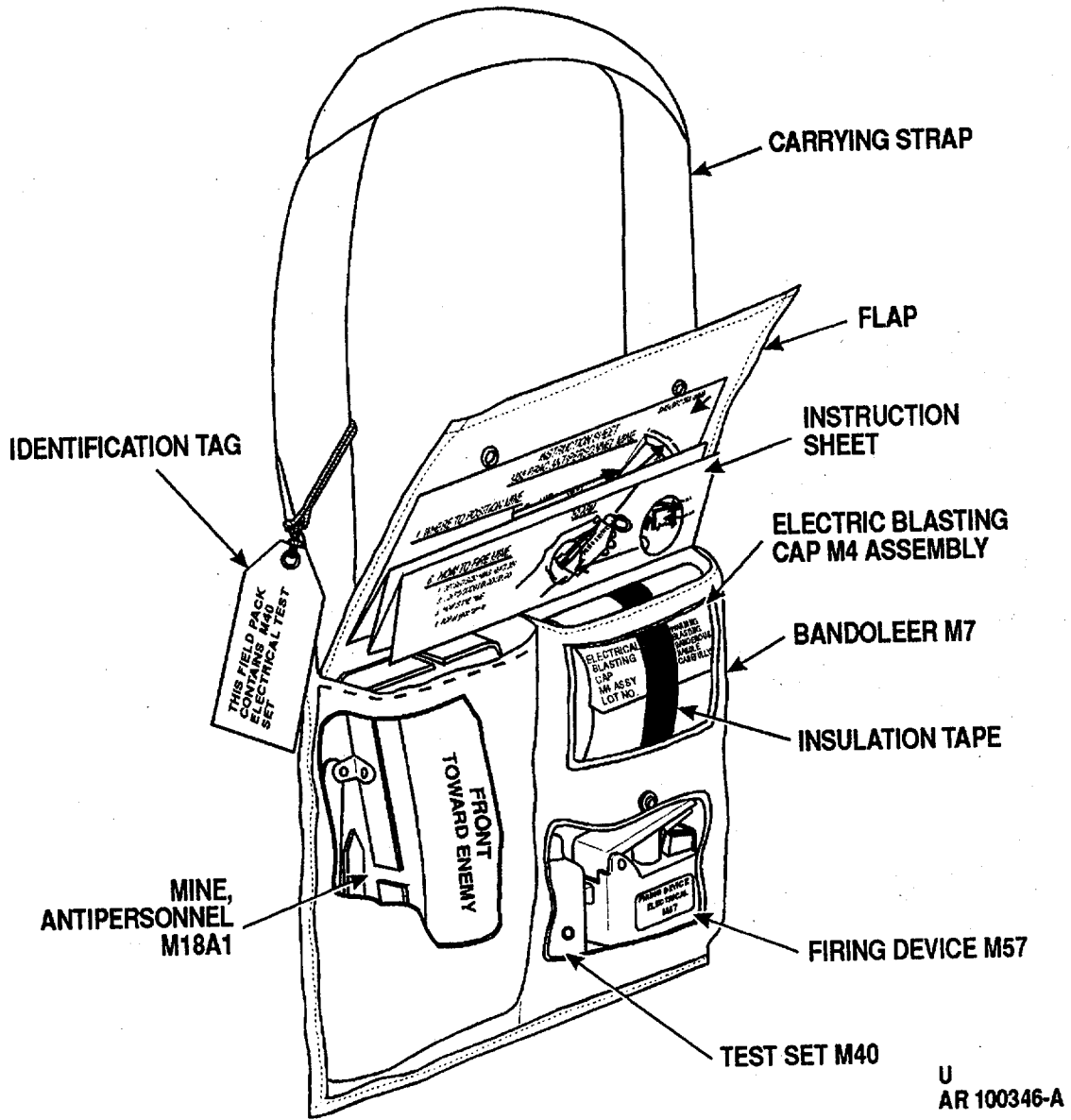

Figure 1-5. Mine, antipersonnel: M18A1 and accessories packed in bandoleer M7.

### 1-8. Mine, Antipersonnel: M86, Pursuit Deterrent Munition (PDM)

#### a. Description.

(1) Mine, M86 (fig. 1-6) is wedge shaped and similar in configuration to, and possesses functioning characteristics of the Adam Mine presently loaded in the 155mm projectile, M731. It contains a safety clip, arming strap assembly, and internal safing and arming device, seven tripline sensors, a reserve battery, electronic circuitry, and a kill mechanism, all encapsulated in molded plastic form. It is packed two to a bandoleer (fig. 1-7).

#### **WARNING**

- **ONCE ARMING STRAP IS LIFTED, DEPLOYMENT IS MANDATORY. DO NOT ATTEMPT TO RESAFE.**
- **SAFE SEPARATION TIME IS 25 SECONDS AFTER STRAP IS LIFTED. LEAVE AREA IMMEDIATELY AFTER EMPLOYMENT AND DO NOT RETURN TO AREA.**
- **THE M86 MINE HAS A SELF-DESTRUCT FEATURE WHICH MAKES IT EXPENDABLE; THEREFORE, DO NOT RETURN TO AREA.**
- **DO NOT DEPLOY MINE BELOW -25°F. IF MINE IS DEPLOYED BELOW -25°F, MINE MAY SELF-DESTRUCT EITHER IN A 5-MINUTE TIMEFRAME, OR LATER THAN**

**THE PROGRAMMED SELF-DESTRUCT TIMEFRAME.**

- **DO NOT REMOVE NOSE PROTECTOR OR NOSE PROTECTOR TAPE. REMOVAL OF TAPE MAY DAMAGE THE ELECTROMAGNETIC RADIATION (EMR) AND ELECTRO-STATIC DISCHARGE (ESD) PROTECTIVE PAINTS.**
- **IF ONE OR MORE TRIPLINES ARE FOUND DEPLOYED PRIOR TO USE, DO NOT ARM OR ATTEMPT TO USE THE PDM. TURN IN MINE FOR DISPOSAL.**

(2) The arming sequence is started by removing the safety clip and the arming strap assembly. The electronics within the mine is then activated by a reserve battery, triplines are deployed, and the mine is then armed. Disturbance of a tripline, or of the mine itself, triggers a switch which initiates a thin layer of liquid propellant resting under the kill mechanism. This action then shatters the plastic mine body and propels the kill mechanism upwards from 6 inches to 8 feet above the ground, where it detonates, propelling fragments at high velocity in a spherical pattern. If the mine is not activated by tripline or disturbance mode, a factory preset self-destruct feature initiates the mine in 4 hours plus 0-20 percent.

b. *Use.* The mine is to be hand emplaced or deployed as a deterrent munition by special forces or selected personnel on operations where they may be pursued by an enemy force on special missions.

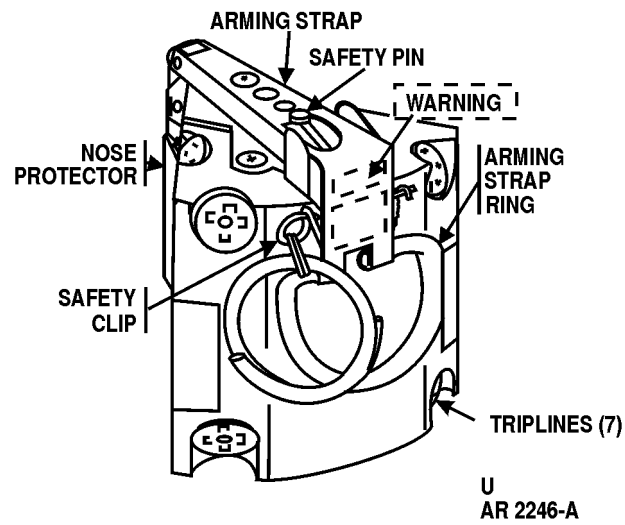

Figure 1-6. Mine, antipersonnel: M86.

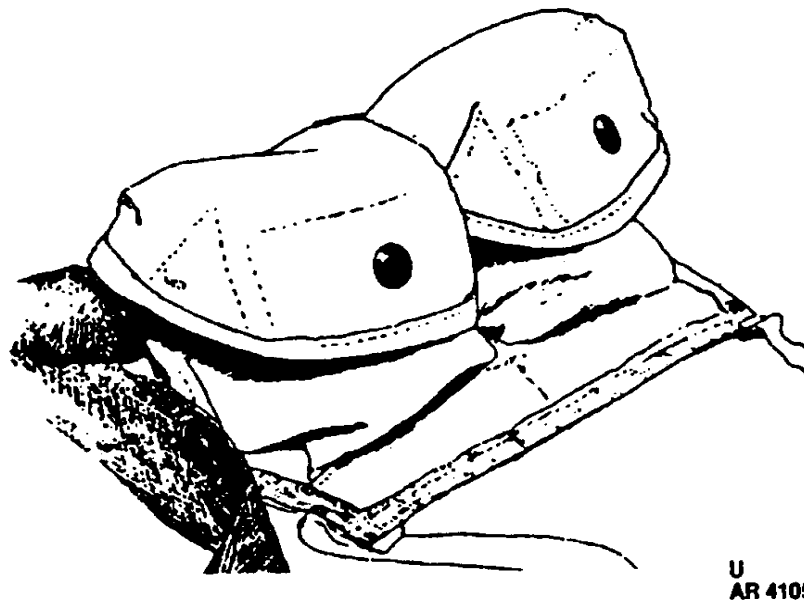

Figure 1-7. Mine, antipersonnel: M86, packed two to bandoleer.

**1-9. Mine, Antipersonnel, Practice: M8, with Fuze, Mine Combination, Practice: M10 or M10A1; Mine, Antipersonnel, Practice: M8A1, with Fuze, Mine Combination, Practice: M10A2 (Figs. 1-8 and 2-17)**

**WARNING**

**USE EXTREME CARE WHEN HANDLING MINE M8. IT CONTAINS A SPOTTING CHARGE ASSEMBLY WHICH CAN BE DANGEROUS TO PERSONNEL WHO ARE NOT UNDER COVER.**

a. *Description.*

(1) Operation of practice mines M8 (fig. 1-8) and M8A1 simulates that of M16 series mines. Physically, the practice mines are the same; the difference between the models is the internal configuration. The projectile in the M8, made of cardboard, contains a spotting charge assembly of black powder, which resembles a blank-loaded shotgun shell with a delay fuze element instead of a primer. The M8A1 uses smoke pellets to indicate activation of mine.

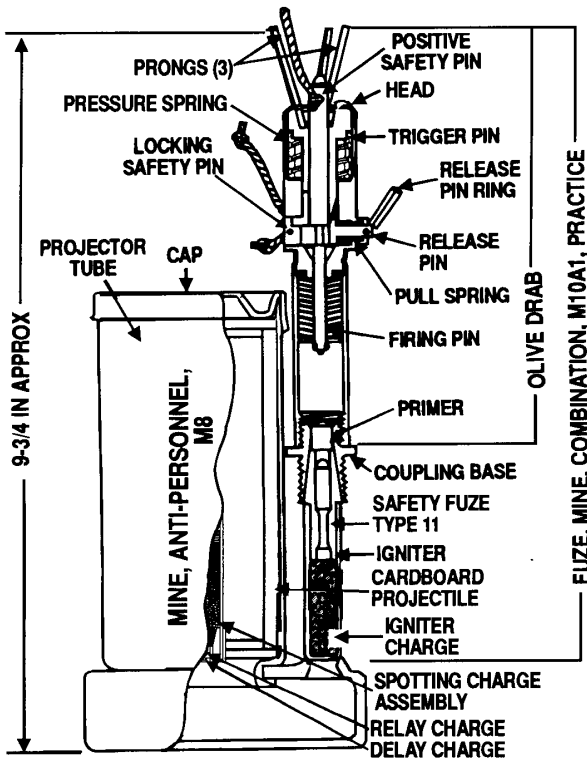

U  
AR 100348

Figure 1-8. Mine, antipersonnel, practice: M8, with fuze, mine combination, practice: M10 or M10A1.

(2) Functioning of mines M8 and M8A1 occurs when the fuze firing mechanism is activated by an applied load of 8 to 20 pounds on any of the prongs or by a pull of 3 to 10 pounds of the trip wire. In the M8, the fuze firing train ignites the delay element in the projectile, and propels it about 2 meters into the air. The delay initiates the spotting charge, which explodes with a loud report and emits smoke. In the M8A1, the fuze firing train ignites yellow smoke pellets through a 4 to 5 second delay. The plastic plug is propelled in the air, allowing yellow smoke to be emitted from top of container.

**NOTE**

No propelling charge is used in these mines, although a propelling charge is used in the M16 series mines. The igniter charge in the fuze expels the cardboard projectile.

b. *Use.* Mines M8 and M8A1 simulate the action of M16 series antipersonnel service mines, and are used to indoctrinate trainees with proper care, handling, emplacement, arming, and disarming techniques applicable to the M16 series mines. They may be used repeatedly by replacing the fuzes and separately requisitionable components. The M8 requires replacement of a mine cap (metal) and cardboard projectile, which contains a spotting charge. The M8A1 requires replacement of a mine plug (polystyrene) and smoke pellets.

**1-10. Mine, Antipersonnel, Practice: M68**

**NOTE**

Plastic body of the inert mine, without components, has been designated Body, AP, Mine M33; for Mine M68.

If non-electric training is required, inert shock tube must be separately requisitioned.

For training with non-electric initiations, inert mini det assembly must be separately requisitioned.

a. *Description.* Figure 1-9 depicts the practice counterpart of mine M18A1. The mines are similar except that the inert loaded mine M33 body replaces the high explosive-loaded mine M18A1 body, and the empty practice blasting cap M10 replaces the loaded blasting cap M4 assembly. For additional information, see paragraph 1-7.

b. *Use.* This mine was developed solely to indoctrinate trainees with proper handling, emplacement, arming, and disarming techniques applicable to service mine M18A1.

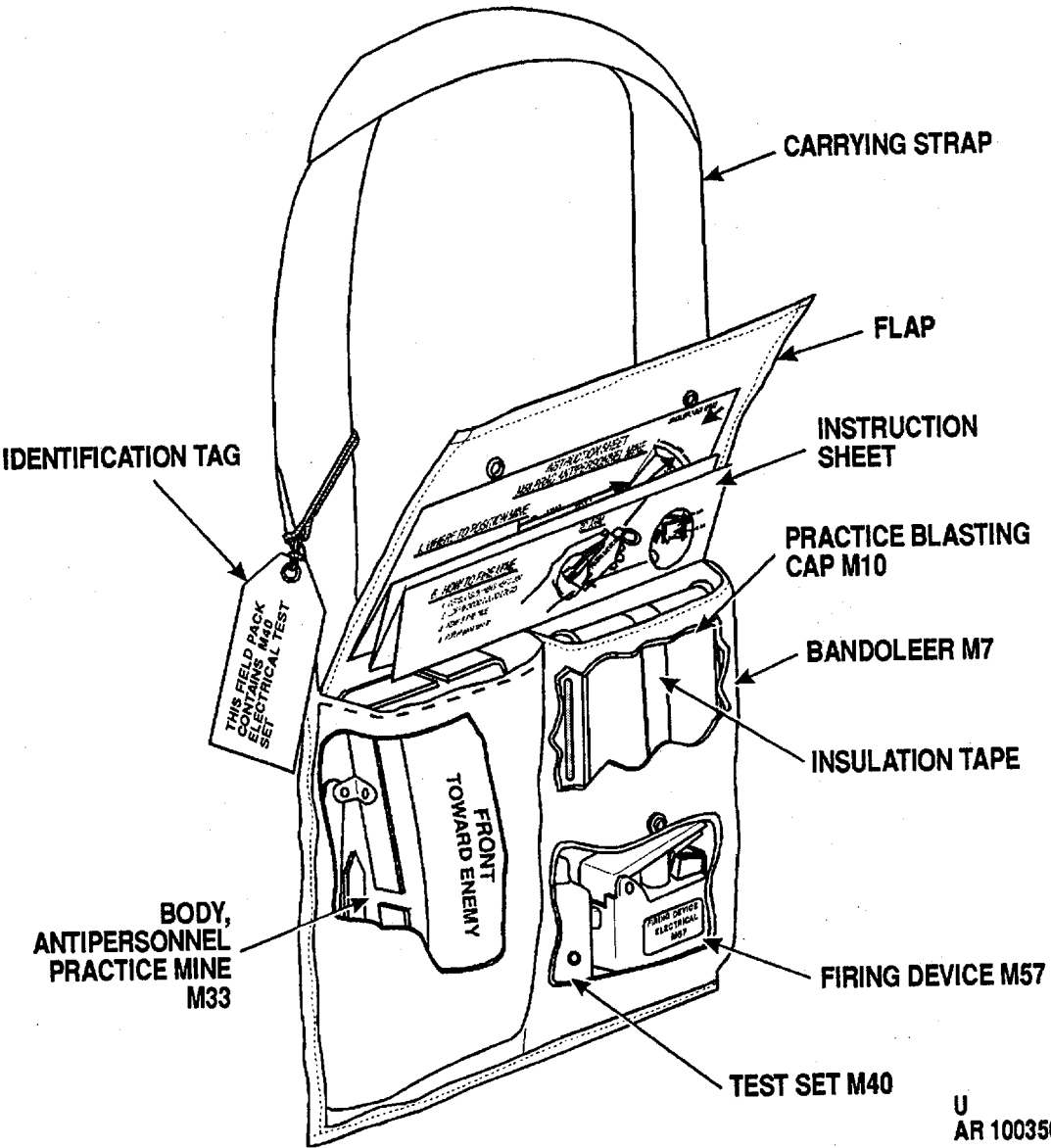

U  
AR 100350-B

Figure 1-9. Mine, antipersonnel, practice, NM: M68.

**1-11. Mine, Antitank: HE, Heavy, M15, with Fuze, Mine, AT, M603 and Activator M1 or with Fuze, Mine: M624**

a. Description.

(1) These mines (figs. 1-10 and 1-11) have a cylindrical, steel body, consisting of a primary fuze well located in center of mine and two secondary wells, one in the side and one in the bottom. Primary fuze well houses the M603 Fuze or M624 Fuze. The activator M1 may be screwed into either secondary fuze well for boobytrapping purposes. A carrying handle is attached to the underside of the mine for carrying purposes.

(2) When armed with the M603 Fuze and the shutter of the arming plug in the ARMED position, a force of 350-750 pounds on pressure plate of mine

depresses the belleville spring of the mine, causing the shutter to depress the pressure plate of the fuze. The fuze pressure plate depresses the fuze belleville spring which snaps into reverse, driving firing pin into the detonator and exploding it. Explosion of the detonator explodes the booster (M120) which, in turn, explodes the main charge.

(3) The M624 fuze consists of an extension rod, adaptor, delay assembly, and the M607 Fuze, which incorporates a tilt rod, safety pin, plastic collar, belleville spring, and PA523 detonator.

(4) To arm the M624 Fuze, the safety pin, band, and stop are removed. The M624 Fuze will function with or without the extension rod.

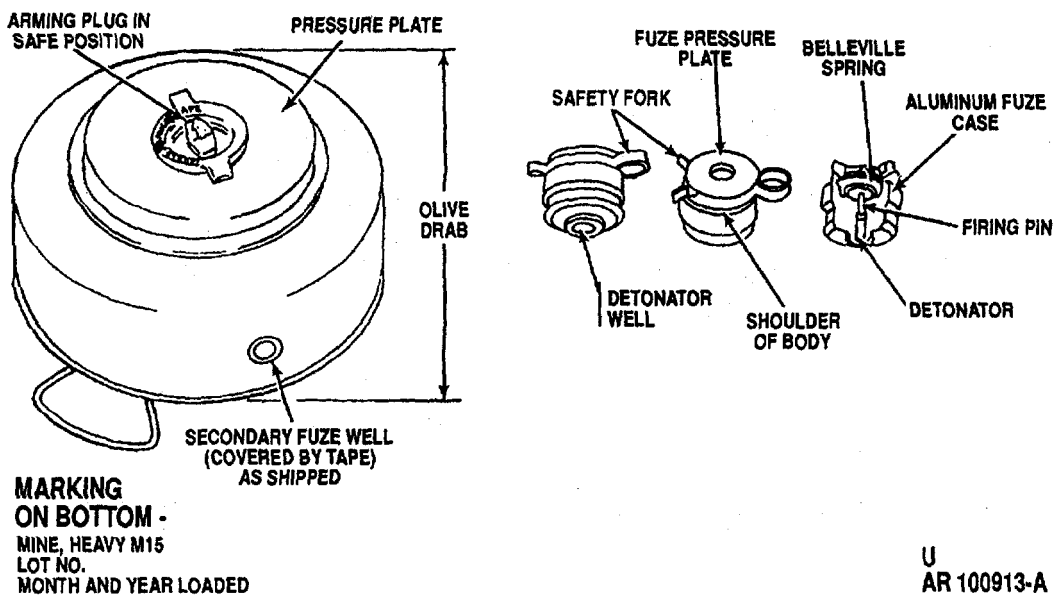

U  
AR 100913-A

Figure 1-10. Mine, antitank: HE, heavy, M15, with fuze, mine, AT, M603.

(a) With the extension rod assembled to the fuze, tilting the end of the rod with a minimum horizontal force of 3.75 pounds, acting through an angle of 20 degrees or more, will shatter or break the plastic collar. This will cause the belleville spring to snap into reverse position and function the PA523 detonator.

(b) When used without the extension rod, a minimum force of 290 pounds on the pressure ring of the fuze causes the belleville spring in the fuze to snap into reverse position and function the PA523 detonator.

(c) The PA 523 detonator initiates the

delay assembly in the adaptor. This sets off the booster charge, M120, which in turn initiates the main charge.

b. Use.

(1) The M15 mine with M603 fuze is a high-capacity mine intended for use against heavy tanks. They may not always destroy an armored tank, but can be relied upon to incapacitate it by damaging its tracks.

(2) The M15 mine with the M624 fuze is effective against vehicles which straddle the mine (tilt rod action), as well as those which run directly over it (pressure action).

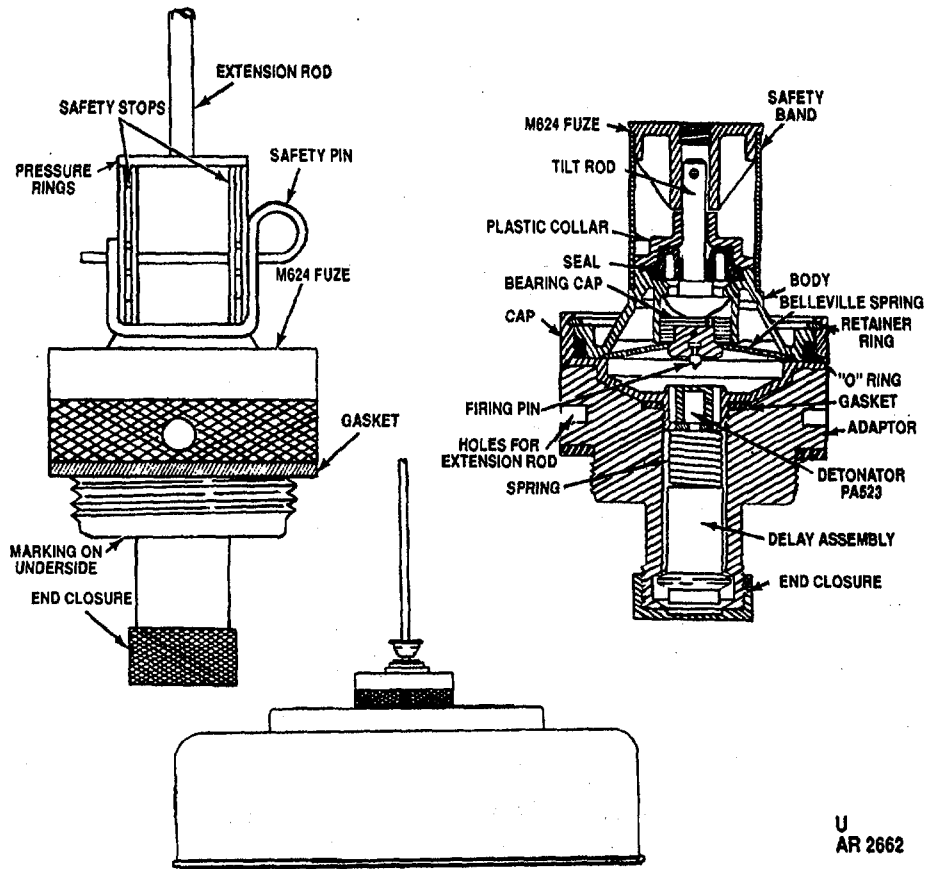

U  
AR 2662

Figure 1-11. Mine, antitank: HE, heavy, M15, with fuze, mine M624 (ARMED).



**1-12. Mine, Antitank: HE, Nonmetallic (NM), M19, with Fuze, Mine, M606**

*a. Description.*

(1) This mine (fig. 1-12) is box-shaped, made of plastic, and has a mechanical, pressure-type, primary fuze M606, also made of plastic. The mine is packed and shipped with fuze assembled, but with detonator packed separately. Due to its all-plastic construction, it is non-detectable by magnetic mine detectors.

(2) When the setting knob on the fuze pressure plate is in the safe position (S), the mine cannot function by action of the main fuze, as the detonator is out of line with the firing pin and the step plate prevents depression of the pressure plate. When the setting knob is turned to the armed position (A), the

movement aligns the detonator with the firing pin and rotates the step plate to a position in which the pressure plate can be depressed. The action permits functioning of the main fuze. The mine is packed and shipped with a fuze safety clip in place to prevent movement of the fuze setting knob. After the safety clip has been removed and the setting knob turned to the armed position (A), a force of 300-500 pounds on the fuze pressure plate depresses a large belleville spring. This action snaps a smaller spring into reverse, driving the firing pin into the detonator and exploding it. Explosion of the detonator initiates the booster pellet which, in turn, explodes the main charge of the mine.

*b. Use.* Mine M19 is intended for use against heavy tanks and heavy tracked and wheeled vehicles.

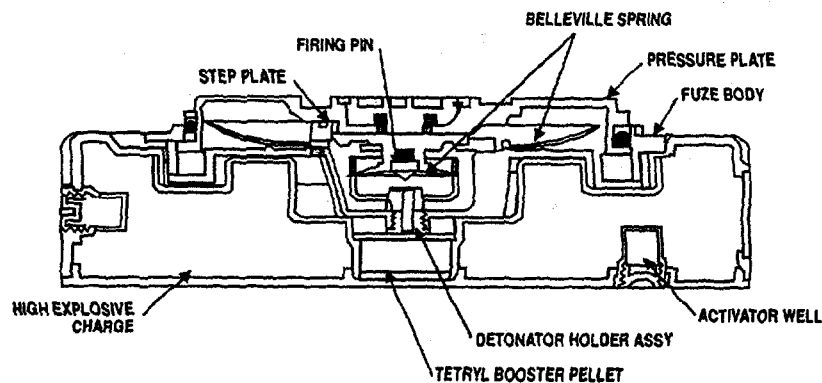
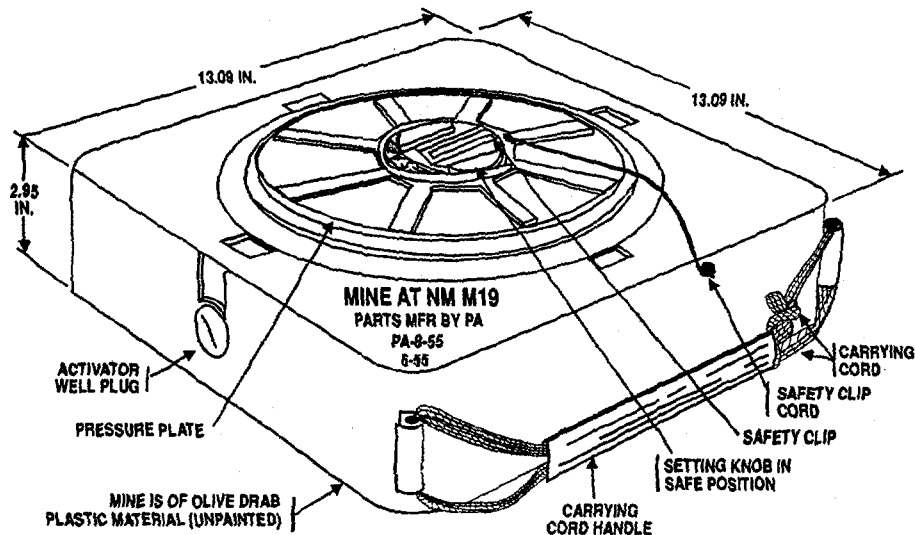

U  
AR 100352

Figure 1-12. Mine, antitank: HE, NM, M19, with fuze, mine, M606.

**1-13. Mine, Antitank: HE, Heavy, M21, with Fuze, Mine, AT, M607**

a. Description.

(1) Mine assembly (fig. 1-13) consists of a cylindrical, steel body which contains a high-explosive charge, a specially-shaped steel dish, and a fuze M607 which is screwed into top of mine. It is effective against the bottom of a vehicle some distance above the ground.

(2) The mine body consists of the following:

(a) The cover assembly, made up of a cover, shipping plug assembly, black powder expelling charge, and charge cap assembly.

(b) The body and base made up of an adjustable carrying strap, attached to the mine for hand or shoulder carrying and for lifting the mine from its emplaced position, a delay assembly, a steel dish, and a high-explosive charge.

(3) The fuze M607 consists of the following:

(a) The firing mechanism formed by an extension rod, tilt rod, firing pin assembly, delay assembly, and detonator M46.

(b) The firing restraint components made up of a band and stop held in place at the top of the fuze by a pull ring assembly.

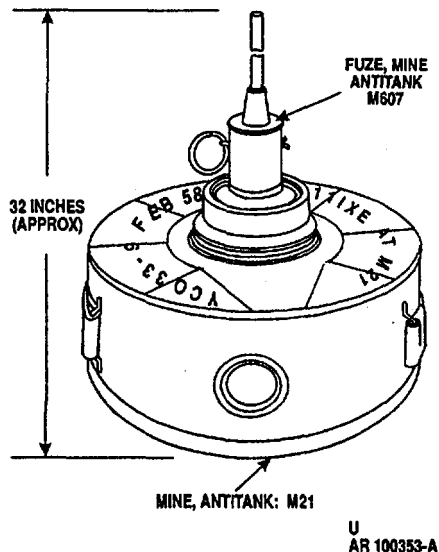

**Figure 1-13. Mine, antitank: HE, heavy, M21, with fuze, mine, AT, M607.**

**NOTE**

**Booster M120 is not shipped in the booster cavity of mine, but in the same packing support.**

(4) The fuze will function without the extension rod.

**NOTE**

**Fuzes manufactured before 1963 have extension rod adapters. Fuzes manufactured after 1963 do not have adapters.**

(a) With the extension rod assembled to the fuze, tilting of the end of the rod with a minimum horizontal force of 3.75 pounds, acting through an angle of 20° or more, will shatter or break the plastic collar and cause the mine to detonate.

(b) When used without the extension rod, a minimum force of 290 pounds on the pressure ring of the fuze causes the belleville spring in the fuze to snap into reverse position and function the detonator M46.

(c) The detonator M46 initiates the black powder charge in the mine body. The blast from the black powder expelling charge blows off the fuze assembly, the cover assembly, and the camouflage material which covers the mine. The pressure created by the burning black powder charge causes the primer to ignite which, in turn, ignites the delay assembly, the relay assembly, the booster, and the high-explosive charge (H6) of the mine.

(d) The detonation of the high-explosive charge blows the body of the mine apart and propels the steel dish upward through the belly of the tank or other vehicle above it.

b. Use. The mine is effective against vehicles which straddle the mine (tilt rod action), as well as those which run directly over it (pressure action).

**1-14. Mine, Antitank: HE, M24, with Fuze M404**

*a. Description.*

(1) Mine (fig. 1-14) is an off-route, anti-tank mine, consisting of a 3.5-inch rocket (modified by adding folding fins), launcher, discriminator firing device, and associated wiring and equipment. Rocket enclosed in a launcher is triggered by the M2 discriminator placed across the target route (fig. 1-15).

(2) A vehicle crossing the discriminator at two segments completes circuitry to the firing device. The firing device, a transistor-controlled firing unit, sends

current through the electrically-initiated squib in the rocket motor igniter, functioning the igniter. The igniter initiates the propellant in the motor, and the rocket is launched from the rocket launcher. The fuze is initiated upon impact and penetration is accomplished by the shaped charge warhead.

*b. Use.* Mine is manually positioned beside wadies, trails, and defiles. It is designed to destroy wheeled and tracked vehicles from remote positions at ranges up to approximately 30 meters.

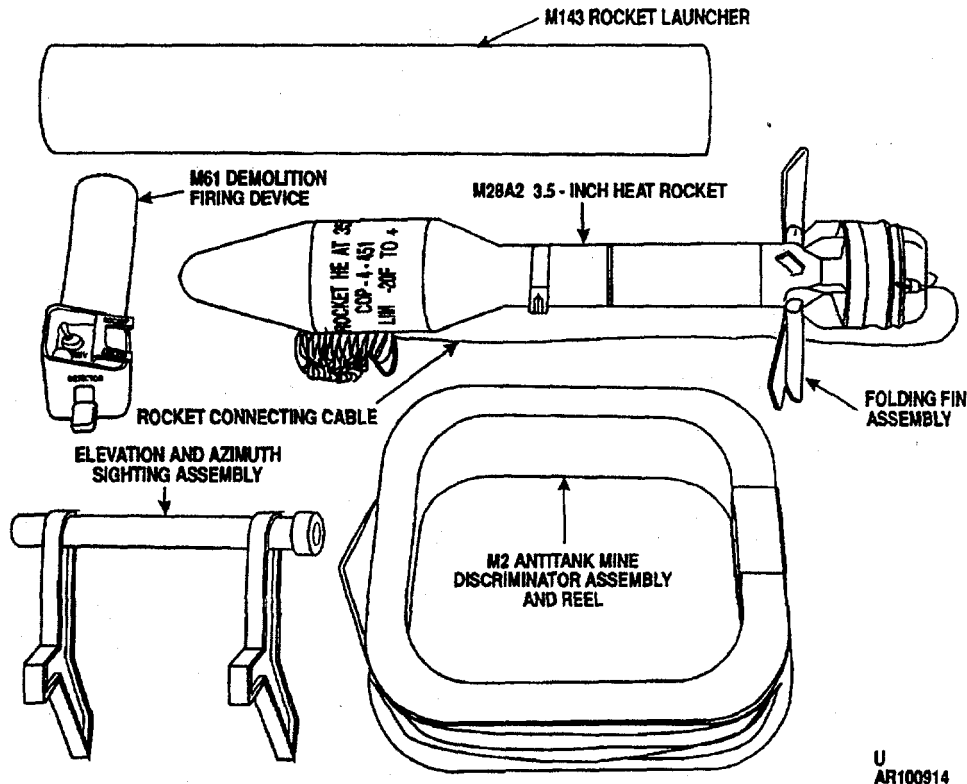

Figure 1-14. Basic components, mine, AT: HE, M24.

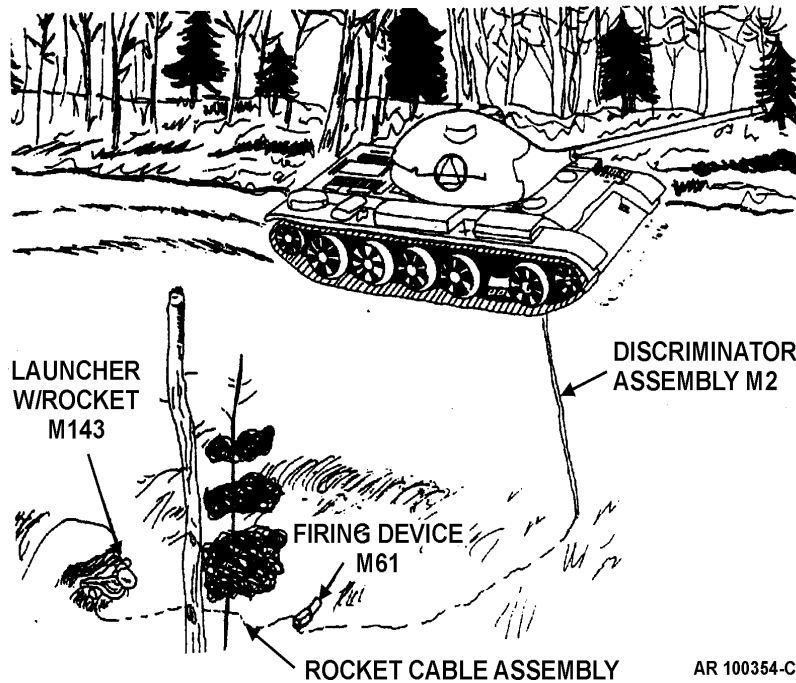

Figure 1-15. Emplaced mine, antitank: HE, M24.

## 1-15. Mine, Antitank, Practice: Heavy, M12A1

### a. Description.

(1) Mine (fig. 1-16) is a flat, cylindrical, steel casing, approximately 3-1/2 inches high and 13-1/4 inches in diameter, similar externally to service mine M15 (except for height). It differs chiefly in having one filler hole in the side and perforations in top and around side secondary fuze well. Mine may be boobytrapped by installation of one or two secondary fuzes, each consisting of practice antitank mine activator M1 and any regular-type firing device having 9/16-inch threads. Although inert, mine has a smoke charge and primer M45 in main fuze M604. Mine is issued empty with arming plug M4 assembled, but without primary or secondary fuze. It may be loaded with sand or inert filler in the field.

(2) A minimum force of  $565 \pm 174$  pounds depresses the pressure plate and the belleville spring of the fuze, which causes depression of the arming plate shutter (Armed position). Depression of the shutter, in turn, depresses the pressure plate and belleville spring of the fuze. Belleville spring of the fuze snaps into reverse, driving the firing pin into the igniter charge of the fuze. The igniter charge of the fuze ignites the smoke composition. The smoke composition explodes, emitting a cloud of smoke and creating a noise.

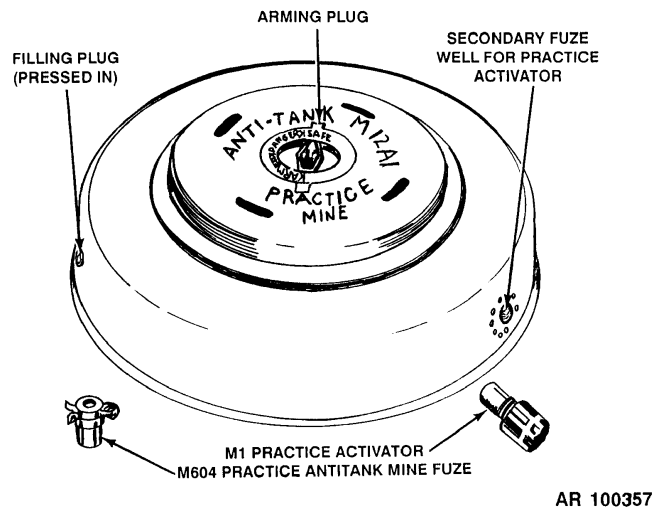

Figure 1-16. Mine, antitank, practice: heavy, M12A1.

b. *Use.* Mine is used for training personnel in precautions and methods to be observed in care, handling, laying and arming, boobytrapping, disarming, and removal of service mine M15. Weight of an intermediate or heavy tank passing over it will cause main fuze of mine to function. Depending upon type of firing device used for boobytrapping, this mine can be functioned by pull or release of either of two tripwires attached to firing device.

**1-16. Mine, Antitank, Practice: Heavy, M20**

a. *Description.*

(1) Mine (fig. 1-17) is a flat, cylindrical, steel casing, approximately 4-7/8 inches high and 13-1/8 inches in diameter, similar externally to service mine M15. It differs chiefly in having three filler holes in the side and perforations in top and around side secondary fuze well. Mine may be boobytrapped by installation of one or two secondary fuzes, each consisting of practice antitank mine activator M1 and any regular-type firing device having 9/16-inch threads. Although inert, mine has a smoke charge and primer M45 in main fuze M604. Mine is issued empty with arming plug M4 assembled, but without primary or secondary fuze. It is to be loaded with sand and fuzed in the field.

(2) For information on functioning of this mine, refer to paragraph 1-15.

b. *Use.* Mine is used for training personnel in precautions and methods to be observed in care, handling, laying

and arming, boobytrapping, disarming, and removal of service mine M15. Weight of an intermediate or heavy tank passing over it will cause main fuze of mine to function. Depending upon type of firing device used for boobytrapping, mine can be functioned by pull or release of either of two tripwires attached to firing device.

**1-17. Mine, Antitank, Training: M80 with Fuze Mine, M606 Inert**

Mine (fig. 1-18) is the duplicate of Mine, AT, HE, NM: M19, and is used for training purposes only. It contains no explosive components and uses the M606 inert fuze.

**WARNING**

**SINCE THE DIMENSIONS ARE IDENTICAL WITH THE LIVE MINE, CARE MUST BE EXERCISED NOT TO USE LIVE COMPONENTS IN THIS INERT MINE.**

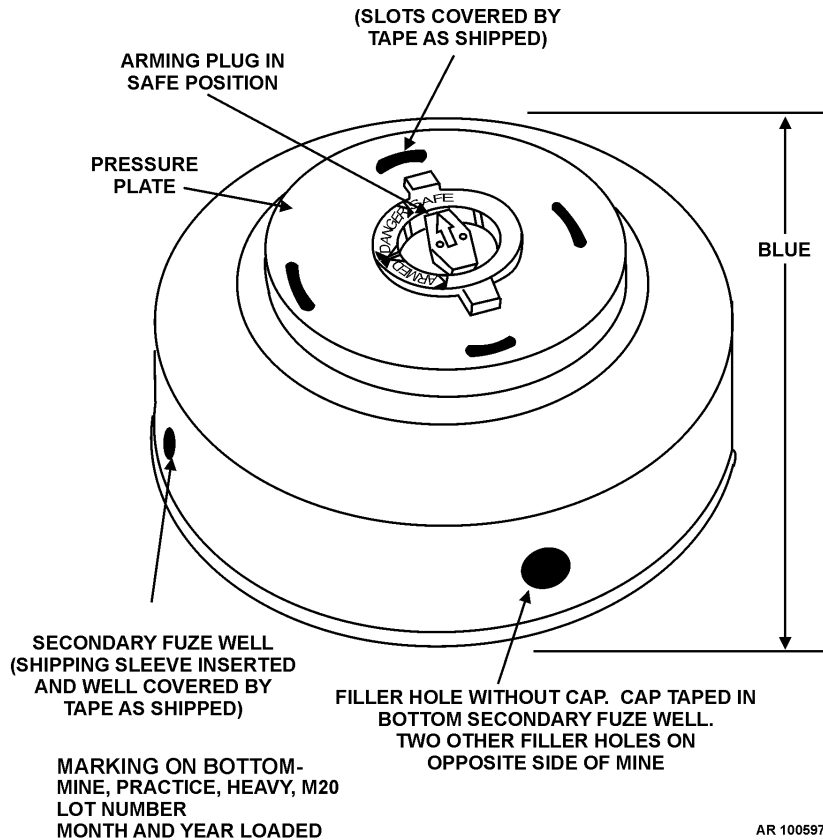

Figure 1-17. Mine, antitank, practice: heavy, M20.

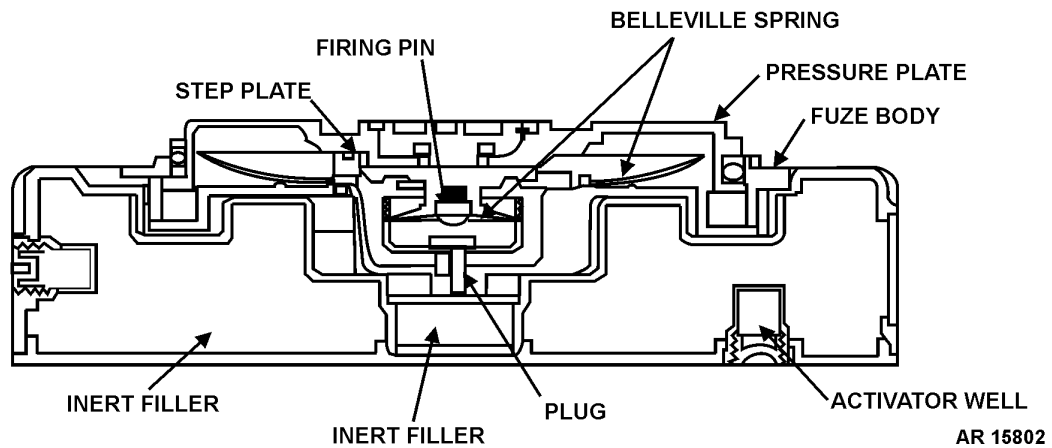
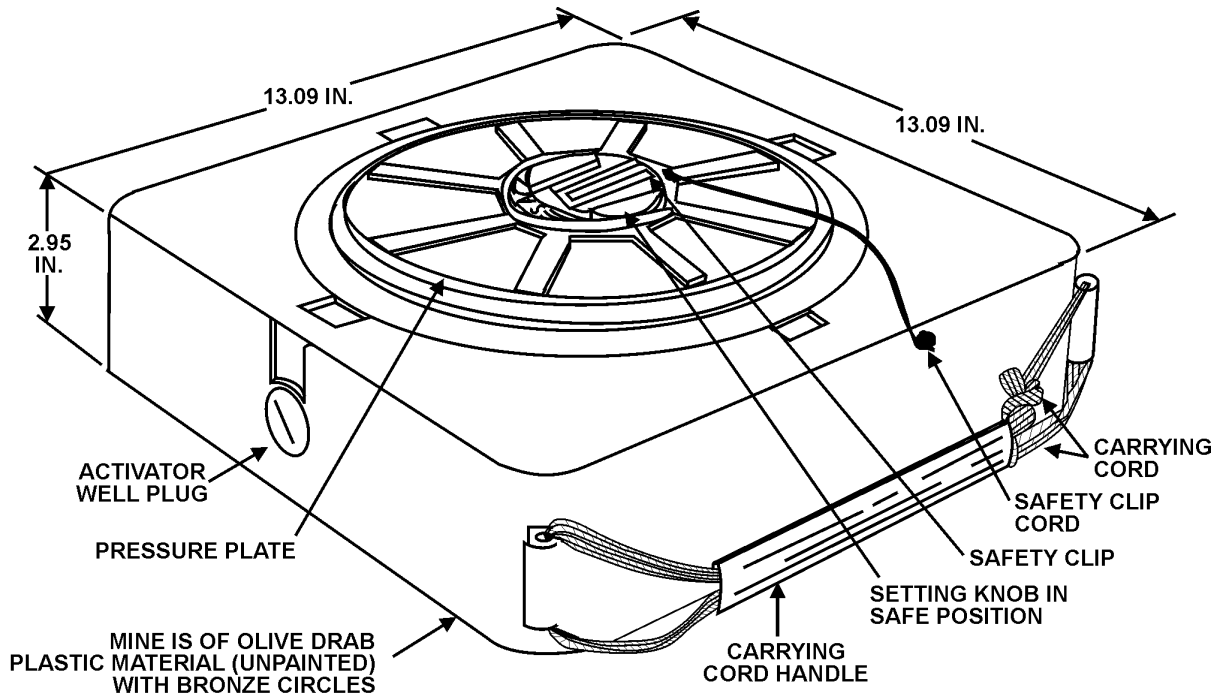

Figure 1-18. Mine, antitank, training: M80 with fuze, mine, M606 inert.

**1-18. Canister, Mine: M87 and M87A1**

a. *Description.*

(1) Each canister mine (fig. 1-19) is an expendable item consisting of an aluminum tube and breech assembly containing five antitank mines and one antipersonnel mine for the M87 canister, and six antitank mines for the M87A1 canister. Also housed in the canister are six transmitter coils attached to a dispersion strap and a propulsion system. The propulsion system consists of a self-contained electrically-initiated primer, and a pressure cartridge assembly containing propellant. The canister is painted in green and has one colored band of yellow triangles near the breech.

(2) When an electrical pulse is received, the electric primer initiates the pressure cartridge expelling a mine stack from the canister. The mine stack consists of five antitank mines and one antipersonnel mine for the M87 canister, and six antitank mines for the M87A1 canister. An interfaced web provides dispersion, self-destruct, and arm signals, set from the dispenser control unit to the mines.

b. *Use.* Canister mine is used with the M139 Mine Dispenser (VOLCANO) (TM 9-1095-208-10-1) to lay a mine field.

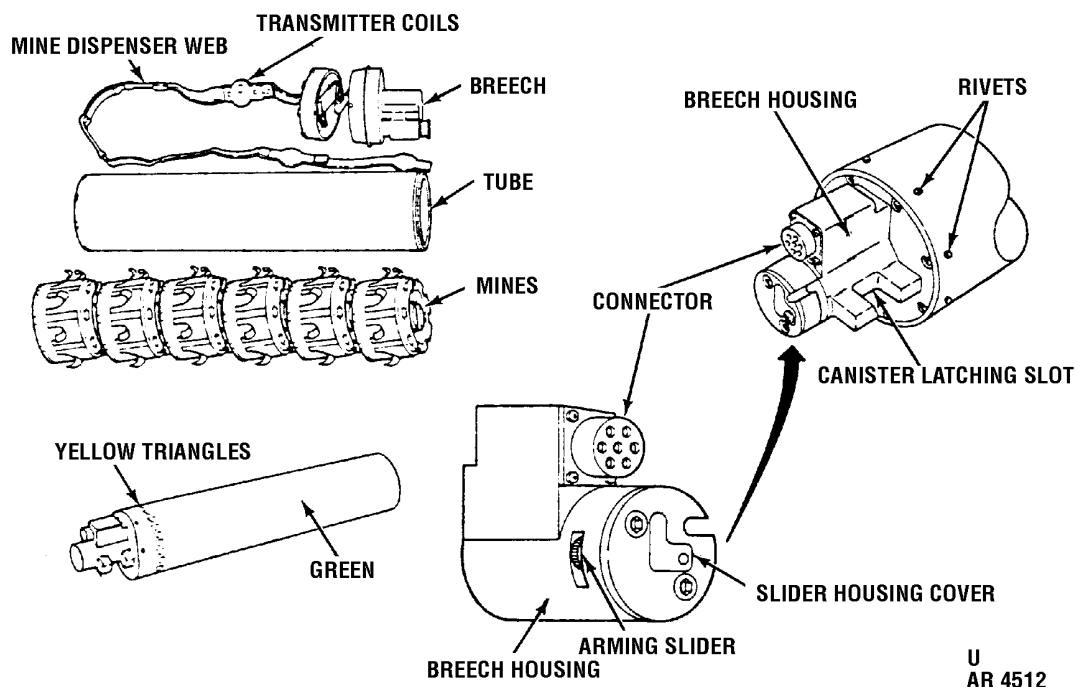

Figure 1-19. Canister, mine: M87 and M87A1.

### 1-19. Canister, Mine, Practice: M88

a. *Description.*

(1) Canister mine (fig. 1-20) is an expendable item consisting of an aluminum tube and breech assembly containing six dummy mines. Also housed in the canister are a dispersion strap and a propulsion system. The propulsion system consists of a self-contained electrically-initiated primer and a pressure cartridge assembly containing propellant. The canister is painted in light blue and has one brown

band and one blue band near the muzzle. The end cap has a brown ring around a blue center dot.

(2) When an electrical pulse is received, the electric primer initiates the pressure cartridge expelling a mine stack from the canister. The stack consists of six dummy mines.

b. *Use.* Canister mine is used with the M139 Mine Dispenser (VOLCANO) (TM 9-1095-208-10-1) in field training in the handling and operation of the M87 Mine Canister and M139 Mine Dispenser.

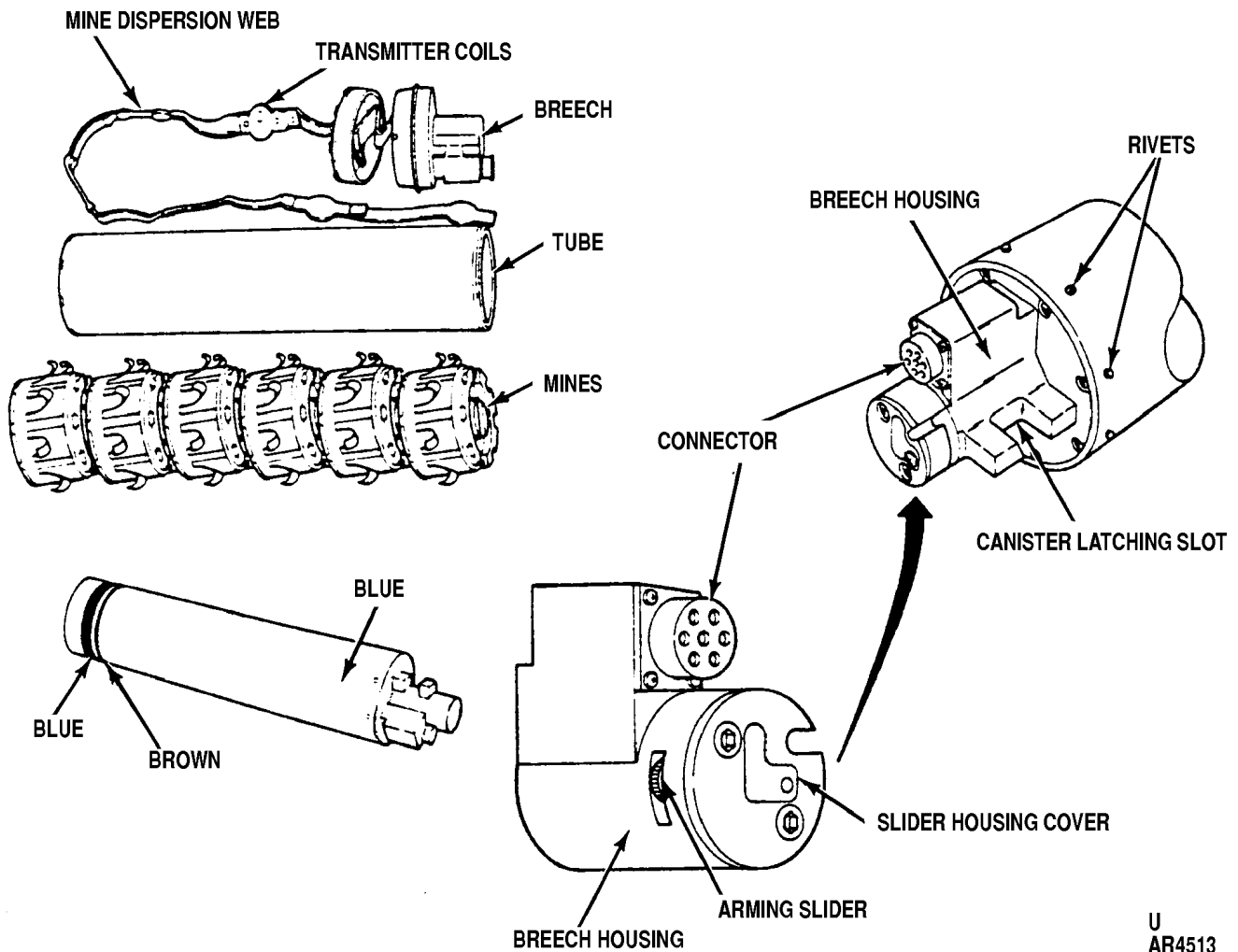

U  
AR4513

Figure 1-20. Canister, mine, practice: M88.



**1-20. Canister, Mine, Training: M89**

a. *Description.*

(1) The M89 Training Canister (fig. 1-21) is a reusable, totally inert canister. The major components of the canister are a breech and connector assembly, a heavy wall tube, an end cap, a switch mounting plate, a rotary four position switch, resistors, and fuse. The M89 Training Canister is physically comparable to the M87 and M88 canisters and is capable of inducing faults into VOLCANO system via the four position switch. The canister is painted in blue.

(2) The M89 Training Canister sends electrical signals to the Dispenser Control Unit (DCU) for simulating the following conditions depending on the switch position setter:

- (a) The functional canister.
- (b) The shorted electric primer canister.
- (c) The launcher rack electronics failure.
- (d) The opened electric primer canister.

b. *Use.* The M89 Training Canisters are used with the M139 Mine Dispenser (VOLCANO) (TM 9-1095-208-10-1) as training tools to practice loading and unloading, to troubleshoot canister and launcher rack errors to practice adjusting the canister loads in the launcher racks to compensate for the bad canister, and to run practice mine laying missions.

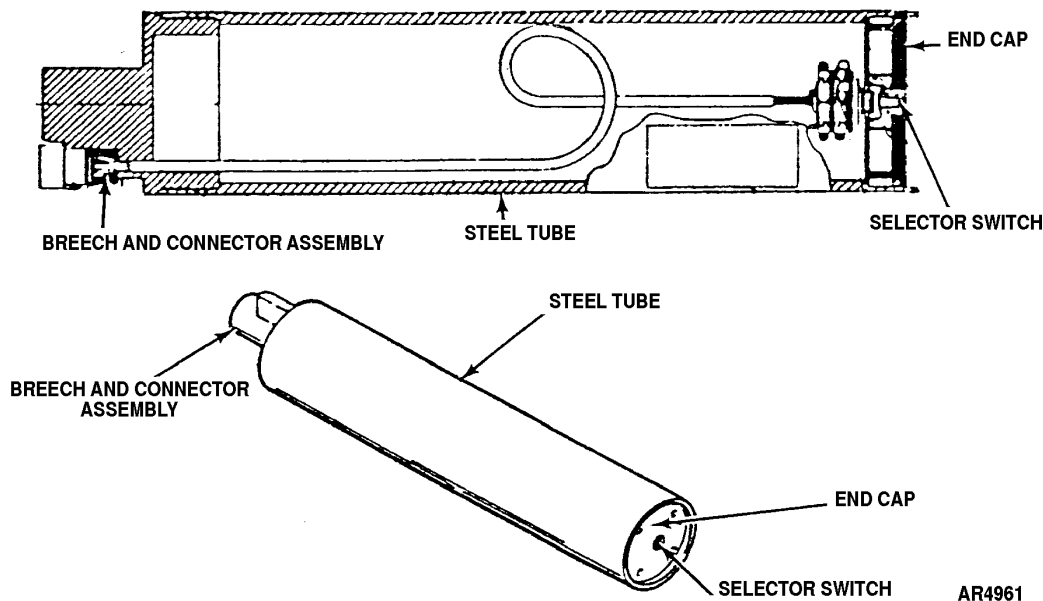

Figure 1-21. Canister, mine, training: M89.

**Section I. SAFETY, CARE, AND HANDLING**

**1-21. Safety**

a. *General Precautions.* Observe precautions generally applicable to use of ammunition and comply with all regulations and local and unit standard operating procedures. For safety rules, missions responsibilities, and safe distance from personnel per pounds of explosive, refer to d(3) below.

b. *Poisonous Fumes.*

(1) The detonation or burning of all explosives produces poisonous fumes. The chemicals used in explosives are poisonous. Personnel should be cautioned against inhal-

ing fumes or ingesting explosives. When explosives are used in closed areas or underground, adequate time must be allowed for the fumes to dissipate before investigation. Explosives should be carefully controlled to prevent diversion to other than the intended purpose; i.e., burning as a source of heat for cooking.

(2) Since explosives contain their own oxidizer, burning explosives cannot be extinguished by smothering. Whenever explosives burn, there is a hazard of possible detonation. Personnel must not attempt to extinguish burning explosives without professional advice and assistance, and should keep their distance because of the toxic fumes.

c. *Misfires.* A misfire is a complete failure to function. Working on or near a misfire is the most hazardous of all operations. Investigation and correction should be undertaken only by the person who placed the charge or by EOD personnel. A misfire should be rare if the procedures in chapter 2 are followed closely.

d. *Safe Distance from Demolitions.*

(1) *Blast effect.* Generally, the greater danger to personnel is the missiles thrown by the explosion. Blast effect (the increase in air pressure) is hazard even though special protection features are used at detonation or demolition sites to eliminate or confine missiles and provide for detonation of charges close to personnel. Personnel provided the minimum protection prescribed in (3) below will not generally be endangered by blast effects.

(2) *Missile hazard.* Explosive can propel lethal missiles great distances. How far an explosion-propelled missile will travel in air depends primarily upon relations between weight, shape, density, initial angle of projection, and initial speed. The missile hazard from steel-cutting charge extends a greater distance under normal conditions than that from cratering, quarrying, or surface charges of bare explosives.

(3) *Safe distances.* The following criteria give the missile hazard distances at which personnel in the open are relatively safe from missiles created by charges placed in or on the ground, regardless of type or condition of the soil (AR 385-63, AR 385-64). Safe distances calculated for selected charge weights are given in table 1-3.

Table 1-3. Minimum Safe Distance for Personnel in the Open

Pounds of Explosive	Safe Distance (in feet)	Pounds of Explosive	Safe Distance (in feet)
1 to 27	900	150	1,590
30	930	175	1,680
35	980	200	1,750
40	1,020	225	1,820
45	1,070	250	1,890
50	1,100	275	1,950
60	1,170	300	2,000
70	1,240	325	2,070
80	1,200	350	2,100
90	1,330	375	2,160
100	1,390	400	2,210
125	1,500	425 or over	2,250

## 1-22. Care and Handling

a. Explosive materials must be handled with appropriate care at all times. The explosive elements in primers, blasting caps, and fuzes are particularly sensitive to shock and high temperatures.

b. Personnel must be trained to handle all items and components, including practice and training items, as potentially dangerous. The same basic safety rules should be followed when using inert training or lecture aids as those when loaded items are being used. Striking, dropping, or handling in other than the manner prescribed for explosive-loaded (live) items should not be permitted. Practice items are painted light blue with white lettering. Practice demolition items with a low-explosive filler have a brown band.

c. In order to keep explosive materials in a serviceable condition and ready for immediate issue and use, the general rules (1) through (5) below apply.

(1) Store explosive materials in the original containers in a dry, well-ventilated place protected from the direct rays of the sun and other sources of excessive heat. Keep sensitive initiators, such as primers, blasting caps, fuzes, and igniters, separate from other explosives.

(2) Keep all materials and containers clean, dry, and protected from possible damage.

(3) Disassembly of explosive components, without specific authorization, is strictly prohibited.

(4) Do not open sealed containers or remove protective safety devices until just before use.

(5) All material prepared for firing but not fired must have protective safety devices installed before returning to original packing. Mark packing appropriately.

d. For more detailed information on care, handling, preservation, and safety-distance requirements, refer to AR 385-64 and DA Pam 385-64.

THIS PAGE INTENTIONALLY LEFT BLANK

## CHAPTER 2 OPERATING INSTRUCTIONS

### NOTE

This chapter contains step-by-step instructions for both normal and long-term emplacement of mines under both dry and wet conditions.

2-1. Mine, Antipersonnel: M14, with Integral Fuze (Fig. 2-1)

a. Casualty Effect and Danger Area.

(1) Mine is capable of inflicting a serious casualty, as it explodes on direct contact.

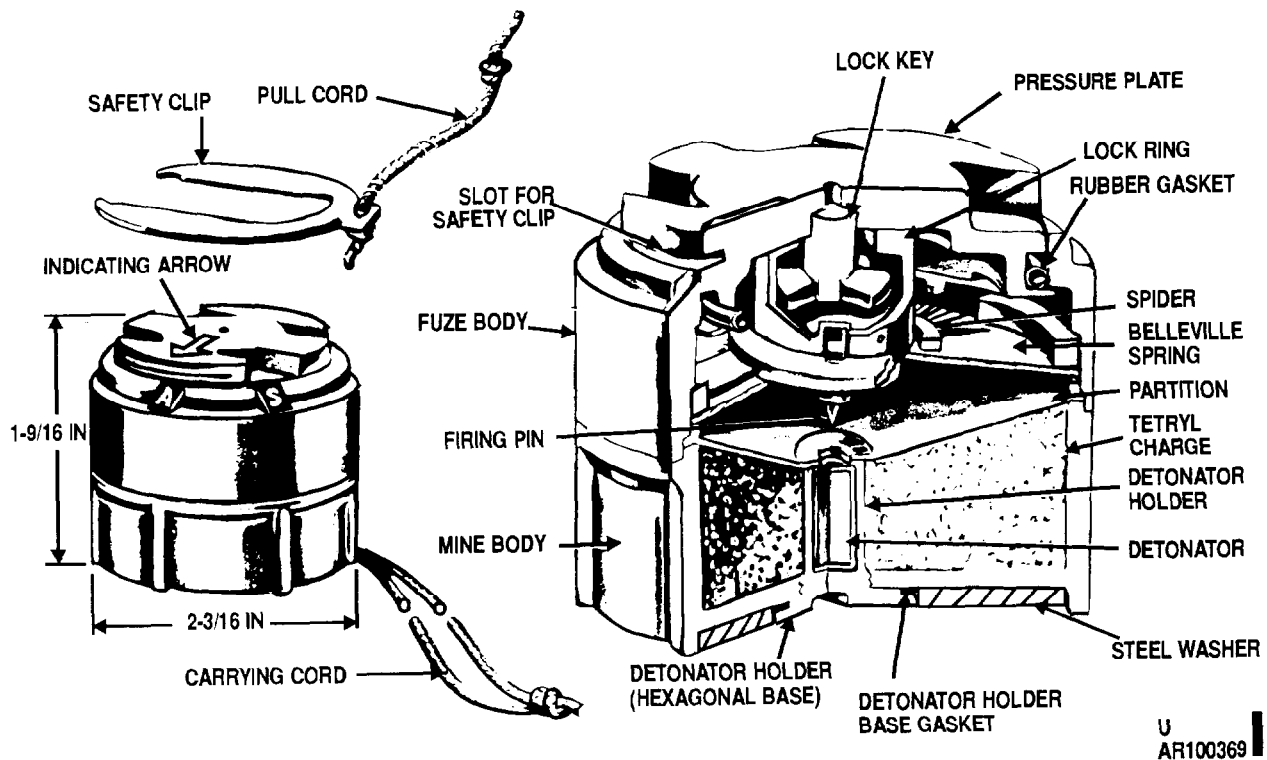

Figure 2-1. Cutaway view of mine, antipersonnel: M14, with integral fuze.

(2) Mine is small, may readily be concealed.

(3) A force of 20-35 pounds on pressure plate will fire the mine.

b. Laying and Arming.

- (1) Remove mine from packing box and examine it. If mine is dented, cracked, damaged, or if washer is missing, do not use.
- (2) Using wrench M22 (fig. 2-2) packed in box with mines, unscrew white plastic shipping plug from detonator well in bottom of mine. Retain shipping plug for future use if required to disarm mine and move to another location.
- (3) Visually inspect position of firing pin. If it extends into detonator well, it is unsafe to use and can function detonator when detonator is assembled to mine. DO NOT USE. Replace shipping plug and set mine aside.
- (4) Inspect detonator well for foreign material. If foreign material is present, remove carefully by tapping mine, held upside down, against palm of the hand until it is removed. If foreign material cannot be removed, replace shipping plug and set mine aside. Do not use.
- (5) Turn mine so that intergral fuze with safety clip is face up.
- (6) Assure that yellow marking indicating arrow points to Safe.
- (7) Grasp mine in one hand and, with the other, pull firmly on carrying cord attached to safety clip (fig. 2-3). Safety clip will come off.

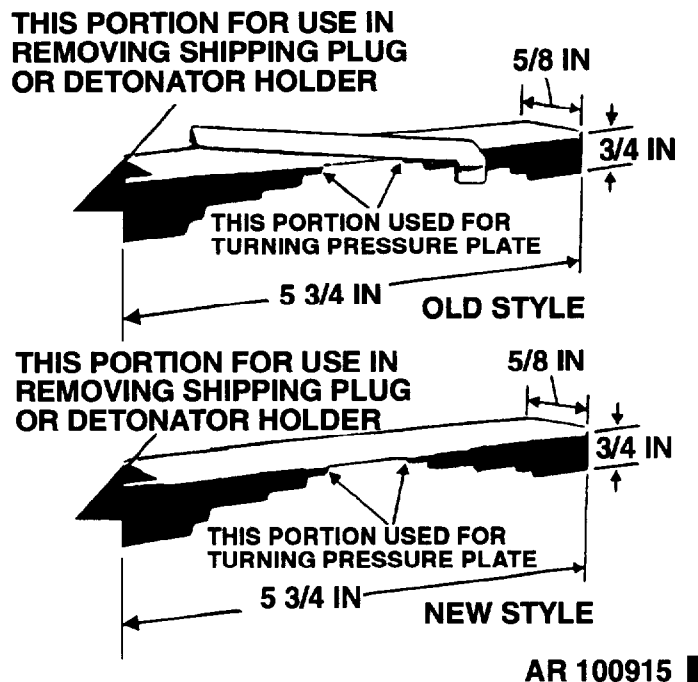
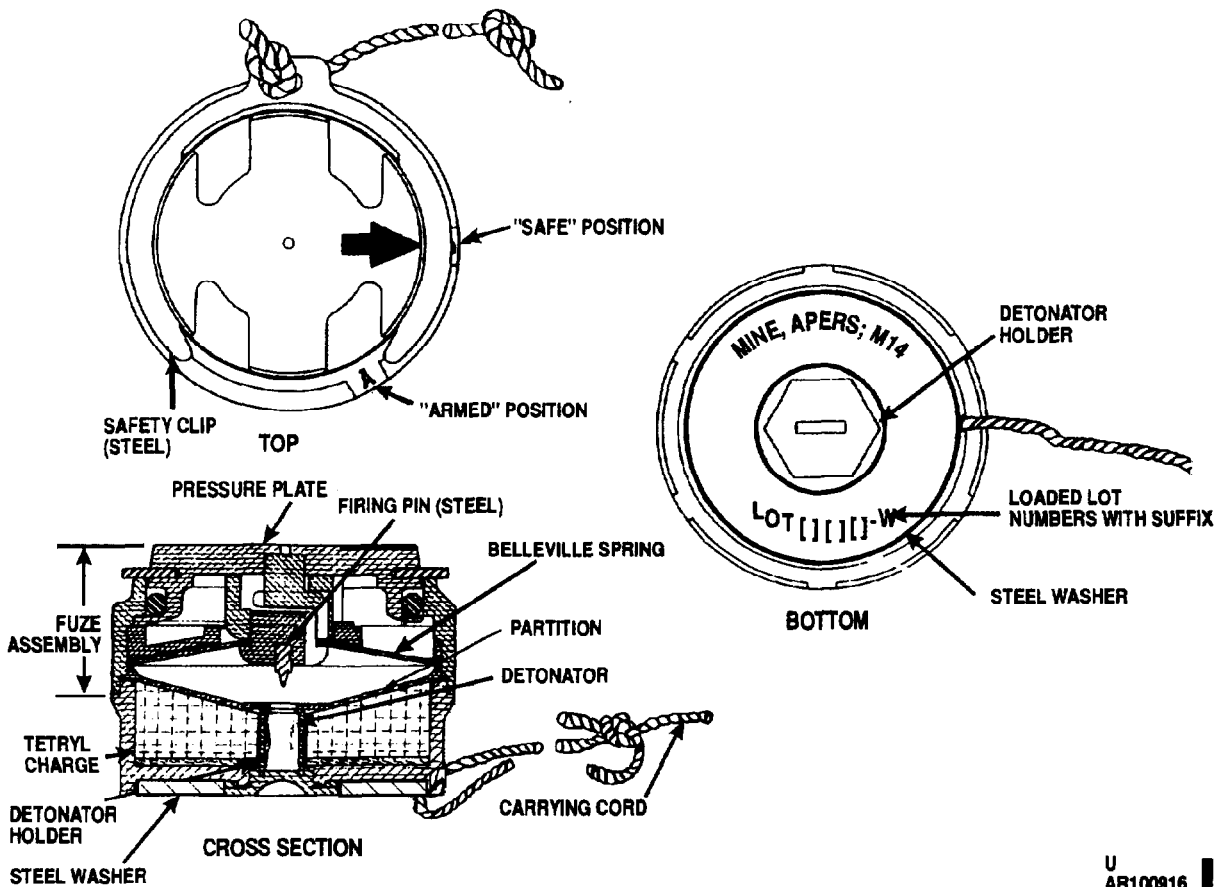

Figure 2-2. Fuze wrench M22 (old and new styles.)



U  
AR100916

Figure 2-3. Mine M14 components.

- (8) Using M22 wrench, turn pressure plate clockwise from S to A (Safe to Armed). If mine pressure plate snaps downward so that top of plate is level with body of mine, and safety clip cannot be inserted, it indicates the mine has functioned. Do not use the mine, discard it and take new one.
- (9) Turn plate counterclockwise so that arrow points to S. Reinsert safety clip.
- (10) Remove detonator holder assembly from mine box and screw tightly into the detonator well. Assure rubber gasket is tightly wedged between the head and body so that no water enters mine, or mine may be a dud.

**NOTE**

For normal emplacement, proceed to (12) below. For long term emplacement, follow procedures in (11) below.

- (11) With index or other convenient finger, smear layer of silicone grease G-697 (about 1/32-inch thick) over and around following locations on mine M14 (fig. 2-4):
  - (a) Detonator holder screwed into mine.
  - (b) On body midway between top and bottom of mine 360° where the two halves of the mine are joined together.
  - (c) On top surface of mine 360° between outer wall and fuze pressure plate of mine. **DO NOT PUT PRESSURE ON PRESSURE PLATE OF ARMED MINE.**
- (12) Dig hole about 4 inches in diameter and just deep enough so that pressure plate extends above ground (about 1-1/2 inches deep). Otherwise, a boot or shoe may bridge the mine.
- (13) Check ground surface at bottom of hole and assure ground is sufficiently solid and able to solidly support mine when pressure is applied to pressure plate. If ground is too soft, place block of wood or other nonmetallic object in bottom of hole for mine to rest on (allow for additional depth if block is used).
- (14) Arm mine with wrench M22 by turning pressure plate to A (Armed). Place mine in hole.
- (15) Hold mine body tightly (no pressure on pressure plate) and remove safety clip.
- (16) Retain safety clip for future use if needed to disarm mine.
- (17) Carefully camouflage mine and remove any excess soil from immediate vicinity of emplaced mine.

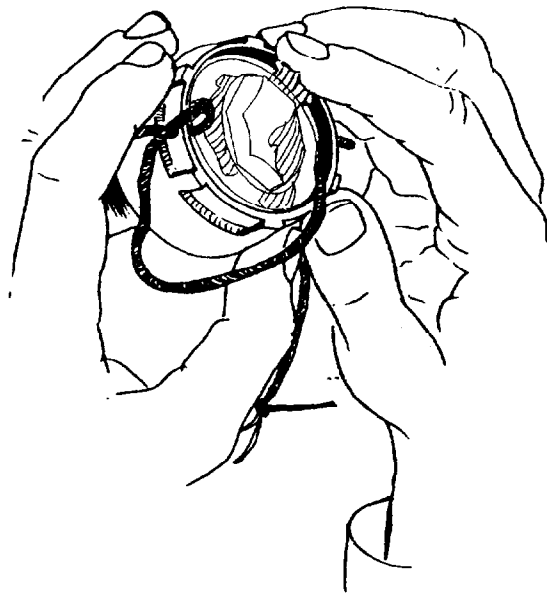

AR 101062

Figure 2-4. Silicone grease G-697 being applied to joint between detonator holder and bottom of mine, AP, M14.

THIS PAGE INTENTIONALLY LEFT BLANK



c. *Boobytrapping.* No provision is made for boobytrapping this mine. There are no secondary fuze wells.

d. *Disarming and Removal.*

- (1) Examine area where mine is emplaced. If it appears tampered with, do not attempt to disarm it. Destroy in place in accordance with FM 20-32.
- (2) If reasonably certain mine or area has not been disturbed, clean topsoil from mine carefully; do not put pressure on mine pressure plate.
- (3) Grasp body of mine firmly with one hand and insert safety clip with other hand.
- (4) With safety clip in place, turn plate with arrow pointing from A to S, thus disarming mine.
- (5) Remove mine from hole.
- (6) Turn mine over and carefully remove detonator from detonator well. Place detonator in safe place.
- (7) Screw plastic shipping plug into detonator well.
- (8) Clean off dirt and grease from body of mine.
- (9) Replace mine into original packing and repack detonator.

e. *Emplacement Life.* The following is the calculated emplacement life in various environments (calculated to 70% effectivity):

Equipment	Estimated life (months)
Temperature zone - clay soil	210
Temperature zone - sandy soil	137
Tropic zone - with heavy rainfall	7

**2-2. Mine, Antipersonnel: M16 Series (M16, M16A1, M16A1 Inert, M16A2) with Fuze, Mine Antipersonnel: M605 (Figs. 1-2, 2-5, 2-6, and 2-7)**

a. *Casualty Effect and Danger Area.*

- (1) Casualty radius is approximately 30 meters.
- (2) Danger area is 200 meters.
- (3) When laying these mines in bare or sparsely covered ground, use of tripwires is undesirable, as a soldier walking erect may see tripwires but is not likely to detect pressure prongs unless alerted to presence of mines.

b. *Laying and Arming* (procedure applicable for all M16 Series Mines).

**WARNING**

**MINE, ANTIPERSONNEL, M16A1 INERT IS A COMPLETELY INERT MINE WITHOUT ANY EXPLOSIVE COMPONENTS. IT IS USED FOR TRAINING PURPOSES ONLY. SINCE THE DIMENSIONS ARE IDENTICAL WITH THE LIVE MINE, CARE MUST BE EXERCISED NOT TO USE ANY LIVE COMPONENTS WITH IT.**

- (1) Remove mine from packing box and examine. If mine is dented, cracked, or otherwise damaged, do not use.
- (2) Unscrew hexagonal plastic shipping plug from fuze well of mine with closed end of fuze wrench M25 (fig. 2-5). Retain shipping plug for future use if required to disarm mine and move to another location.

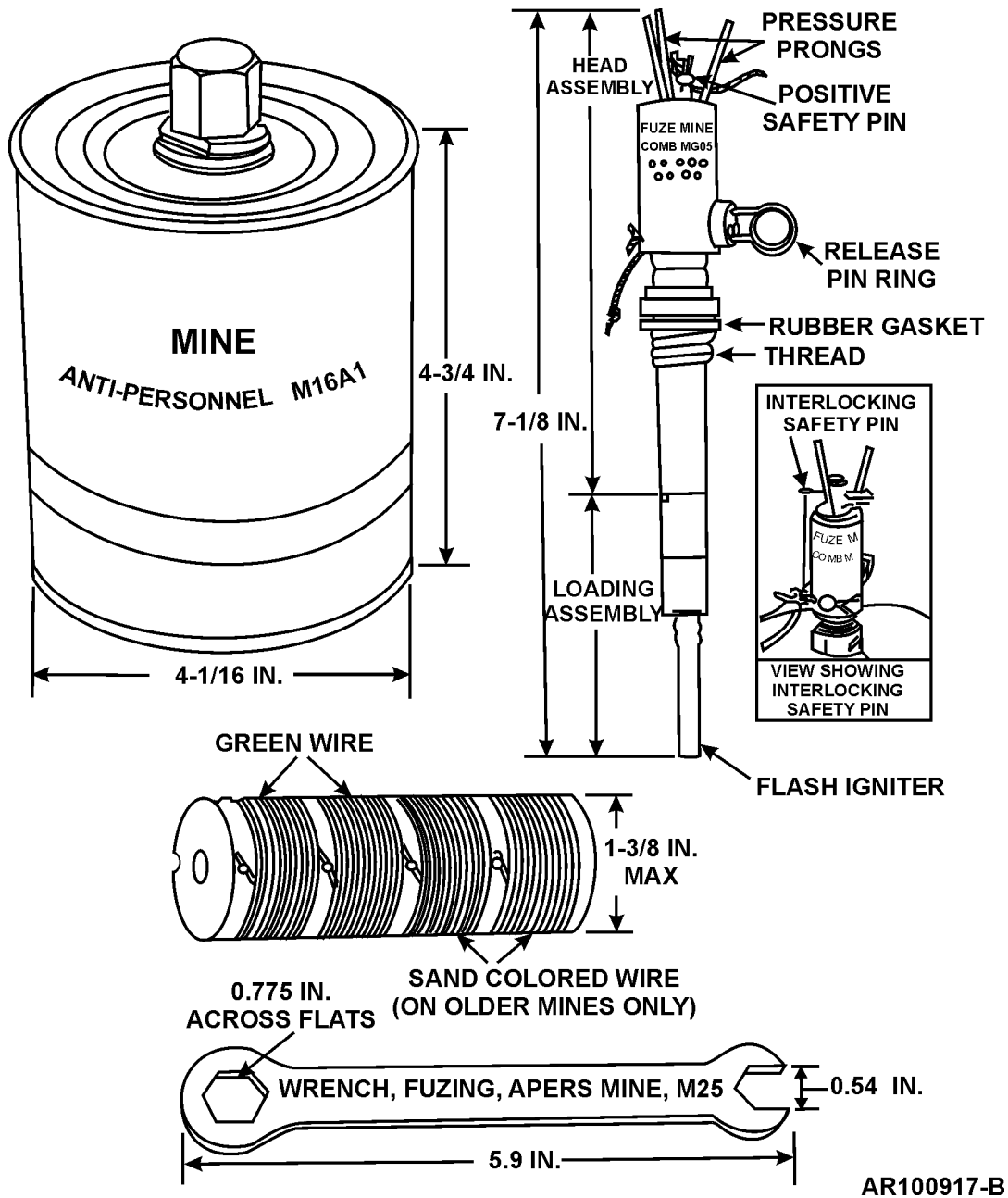

Figure 2-5. Mine, antipersonnel: M16A1, with fuze, mine antipersonnel: M605, with tripwire and fuzing wrench M25.

- (3) Examine fuze well and flash tube of mine for evidence of obstruction or foreign matter. If there is foreign matter present, turn mine upside down and gently tap the bottom to dislodge any foreign matter.
- (4) Set mine down and pick up metal container of fuzes M605. Open container and remove a fuze.

**WARNING**

**WHEN HANDLING THE M605 FUZE, ALWAYS TAKE CARE TO AVOID PUSHING ON THE CIRCULAR DEPRESSION IN THE BODY OF THE FUZE OPPOSITE THE TRIPWIRE PULLING BOSS. THIS IS THE SLIDER HOLDING THE FIRING PIN AND ANY MOVEMENT (EVEN THE SMALL AMOUNT ALLOWED WITH THE SAFETY COTTER PIN IN PLACE) CAN PLACE THE FIRING PIN CLOSER TO THE POINT OF RELEASE.**

**WHEN ARMING THE M605 FUZE, ALWAYS PULL THE POSITIVE SAFETY PIN WITH FINGERS (RATHER THAN JUST PULLING ON THE STRING) TO AVOID IMPARTING A SHOCK TO THE FUZE WHICH COULD ACTUATE IT.**

- (5) Carefully examine fuze assembly for evidence of damage or missing safety pins. Assure that safety pins move freely in safety pin holes. Assure rubber gasket is around fuze base.
- (6) With open end of wrench M25, assure bushing adapter on fuze well is tight.
- (7) Screw fuze assembly into fuze well and, with wrench, assure fuze is tight and rubber gasket is between fuze body and bushing adapter on mine.
- (8) For long term emplacement, smear a layer of silicone grease G-697 on following locations (fig 2-6):
  - (a) Bushing adapter and body of fuze where it enters mine.
  - (b) Base of fuze head where it swivels on fuze body.
  - (c) Upper portion of fuze head where prongs are located.

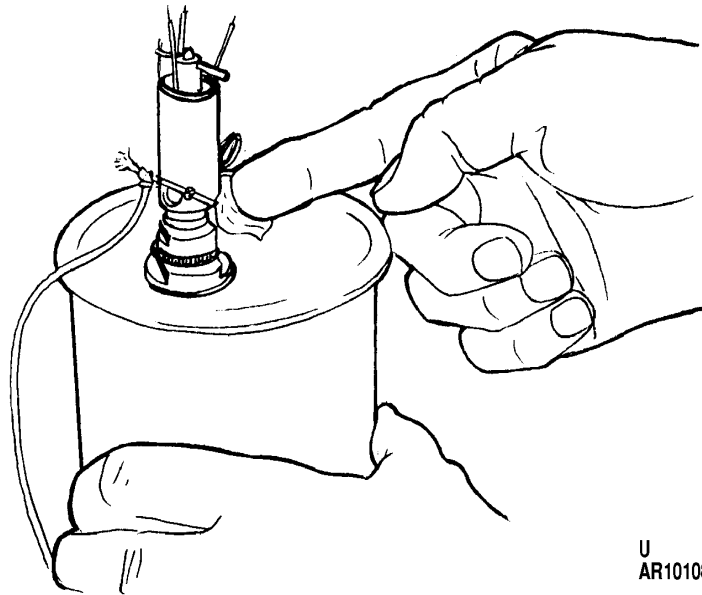

U  
AR101083

Figure 2-6. Apply silicone grease G-697 on mine M16A2.

**THIS PAGE INTENTIONALLY LEFT BLANK**

- (9) Dig hole about 6 inches deep and 5 inches in diameter.
- (10) Place mine in hole. Sympathetic detonation will occur when mines are laid 1.5 to 2 meters apart. For pressure operation, continue with (11) below. For tripwire operation proceed to (12) below.
- (11) Bury mine with fuze pressure prongs extending slightly above ground level.
  - (a) Cover sides of mine with dirt, pressing it firmly around sides of mine, leaving head of fuze exposed.
  - (b) Remove locking safety pin; then remove interlocking safety pin from positive safety pin (fig. 2-5). Retain safety pin for future use if required to disarm mine and move to another location.
  - (c) Arrange pull cord on positive safety pin so that it will withdraw easily.
  - (d) Camouflage installation in accordance with instructions in FM 20-32.
  - (e) Remove positive safety pin, thus arming fuze. If positive safety pin is hard to remove, do not force it. Obtain new fuze. Retain safety pin for future use if required to disarm mine and move to another location.
  - (f) Pressure of 8-45 pounds on pressure prongs will function mine.
- (12) For tripwire installation (fig. 2-7) perform the following operation:
  - (a) Cover mine with dirt, pressing it firmly around sides of mine, 2-10 leaving release pin ring in head of fuze and pressure prongs exposed.
  - (b) Locate two anchor stakes approximately 10 meters from mine and drive stakes into ground so that tripwires when attached will form a wide 'V'.  
A third stake may be used, if desired, for a third tripwire so that the mine can be controlled in all directions.
  - (c) Attach separate wire securely to each stake, then fasten free end to release pin ring on fuze. Leave slight slack in the wires so that no pull will be exerted on release pin ring when the safety pins are removed, as this may cause functioning of the fuze.
  - (d) Remove locking safety pin; then remove interlocking pin from positive safety pin. Retain safety pin for future use if required to disarm mine and move to another location.
  - (e) Arrange pull cords on positive safety for easy withdrawal.
  - (f) Camouflage installation in accordance with instructions in FM 20-32, being careful not to cover pullcord on positive safety pin.
  - (g) Remove positive safety pin, thus arming fuze. If positive safety pin is hard to remove, obtain new fuze. Retain safety pin for future use if required to disarm mine and move to another location.
  - (h) Pull of 3-15 pounds on tripwire attached to release pin ring will release firing pin and function mine.

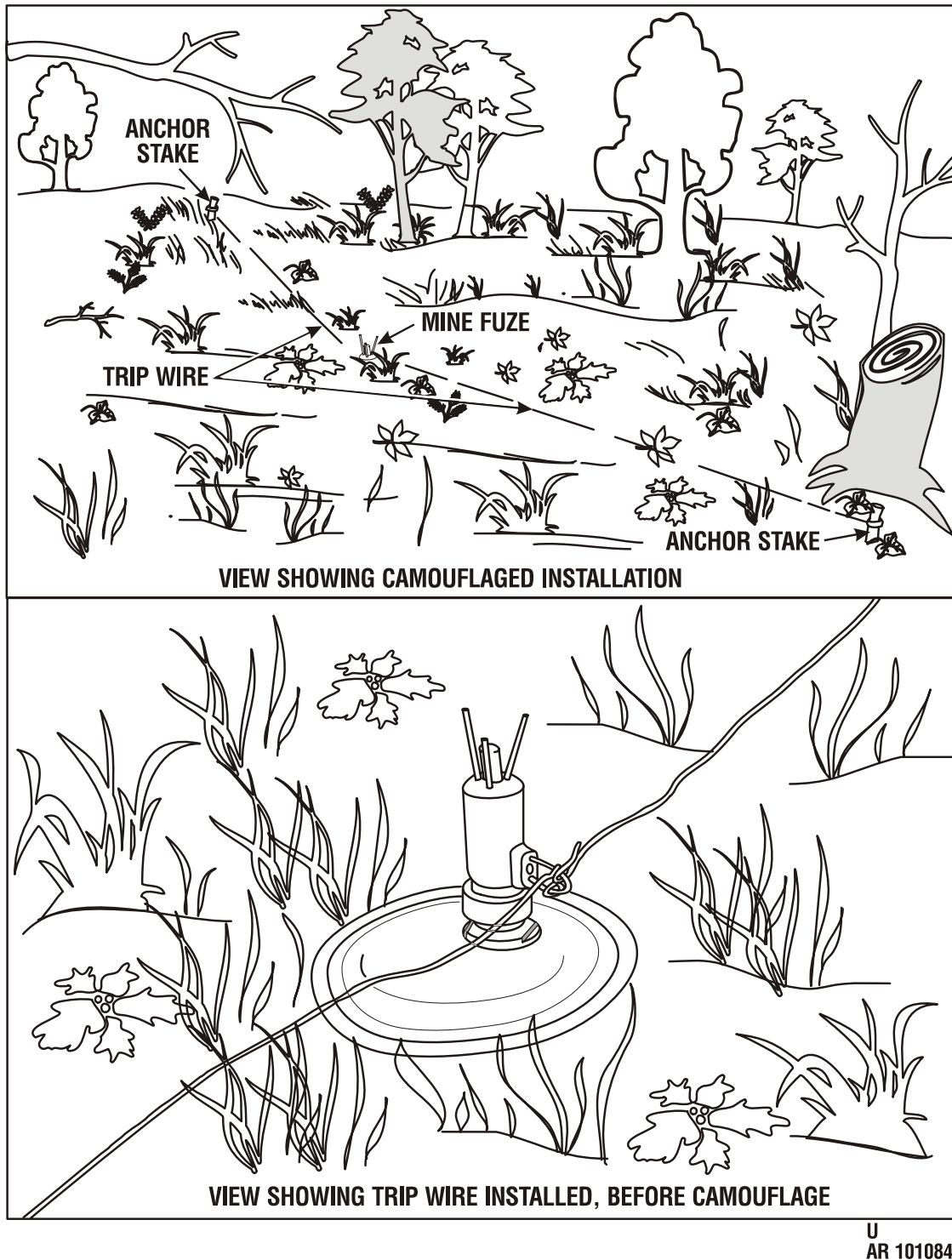

Figure 2-7. Installation of tripwire for mine M16A2.

c. *Boobytrapping.* No secondary fuze wells for boobytrapping are provided in M16 series mines. In any case, boobytrapping will be done only by specially trained personnel. Refer to FM 5-31.

d. *Disarming and Removal.*

**WARNING**

**DO NOT ATTEMPT TO NEUTRALIZE DAMAGED MINE. EITHER DESTROY IT IN PLACE WITH PREPARED CHARGE, OR ATTACH 50-METER LENGTH OF WIRE OR ROPE TO HEAD OF FUZE AND, FROM SECURE PROTECTED POSITION, PULL MINE FROM HOLE. DESTROY THE DAMAGED MINE BY DETONATING REMOTELY IN A SAFE AREA.**

- (1) Check mine and area for boobytraps. If clear, proceed.
- (2) Carefully uncover top of mine.
- (3) Examine mine for evidence of malfunctioning, damage, or tampering.
- (4) If mine does not appear to be damaged or tampered with, carefully insert original safety pin, if available, or length of steel wire or nail of proper diameter through positive safety pin hole.
- (5) Insert safety pin, length of steel wire, or nail through locking safety pin hole (fig. 2-5) opposite release pin ring.
- (6) After safeties have been inserted, cut all slack wires attached to release pin ring.

- (7) Carefully dig around sides and bottom of mine, always being alert for boobytraps.
- (8) Lift mine from ground.
- (9) Unscrew and remove fuze assembly.
- (10) Replace plastic shipping plug in fuze well.
- (11) Restore mine and fuze to original condition, if possible.
- (12) Replace mine and fuze in packing box.

e. *Emplacement Life.* Emplacement life of M16 series mines (calculated to 70% effectivity) in various environments follows:

Equipment	Emplacement life (months)
Temperature zone - clay soil	96
Temperature zone - sandy soil	96
Tropic zone - with heavy rainfall	139

**2-3. Mine, Antipersonnel: M18A1, with Electric Initiation System (Fig. 2-8)**

a. *Casualty Effect and Danger Area.*

(1) *Fragmentation.* Mine M18A1 delivers 700 steel balls in a fan-shaped pattern approximately 2 meters high and 60 degrees wide at a range of 50 meters (fig. 2-9). These balls are effective up to a range of 100 meters and are dangerous up to 250 meters in front of the mine.

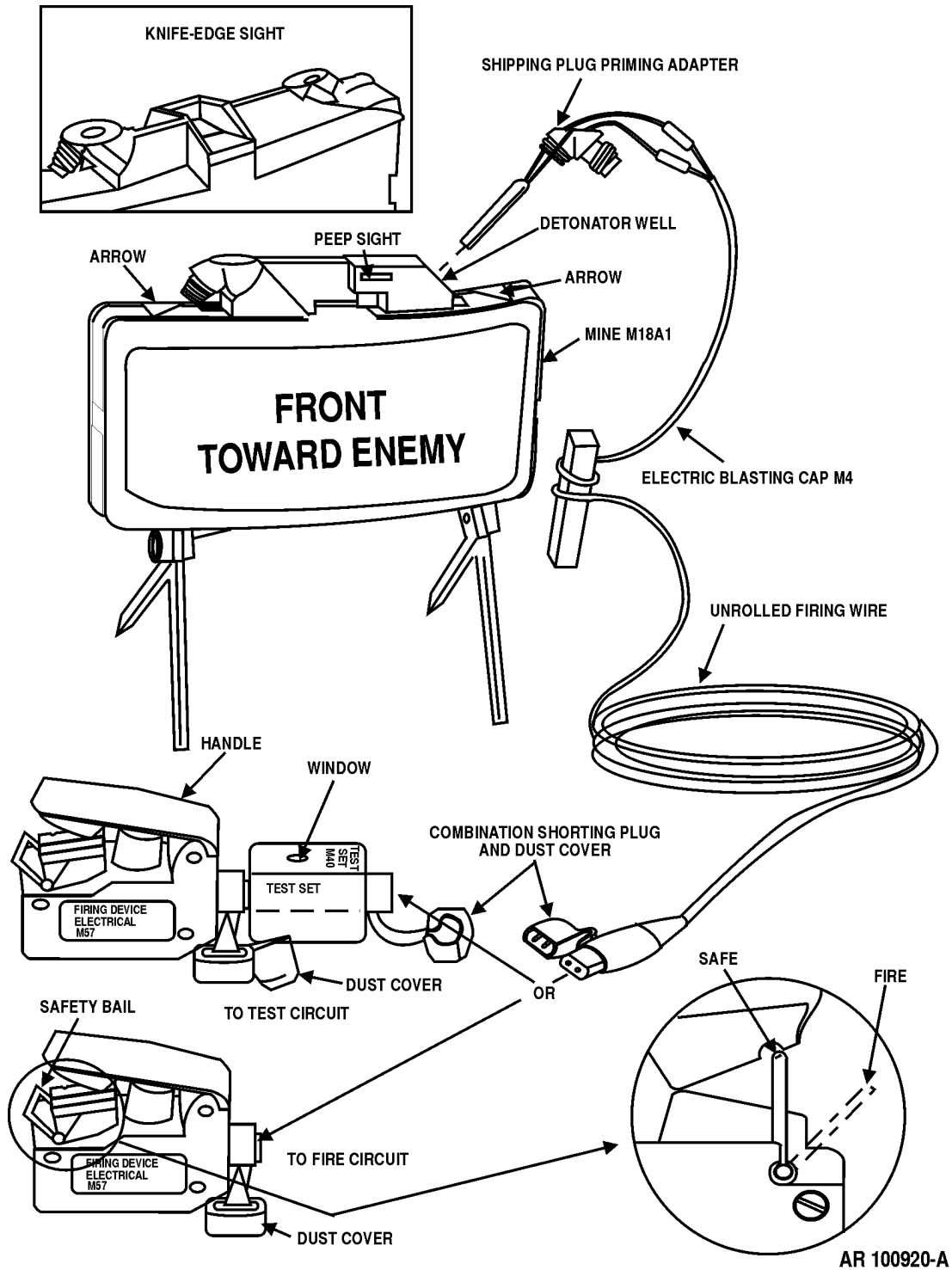

Figure 2-8. Mine, antipersonnel: M18A1, electric initiation system with accessories.



(2) *Backblast.* Within an area of 16 meters (fig. 2-9) to the rear and sides of the mine, backblast can cause injury by concussion and secondary missiles. Up to 100 meters to rear and sides of mine, all friendly personnel must be under cover for protection from secondary missiles.

(a) *Radius of 0 to 16 meters from mine.* Friendly troops are prohibited in this area.

(b) *Radius of 16 to 100 meters from mine.* Minimum safe operating distance from mine is 16 meters. At this distance, the operator should be in a foxhole or dugout or should lie prone, preferably in a depression. All friendly troops, including operator, within 100 meters of the mine should take cover behind a boulder, tree, or similar shelter to prevent being injured by flying secondary missiles, sticks, stones, pebbles, etc.

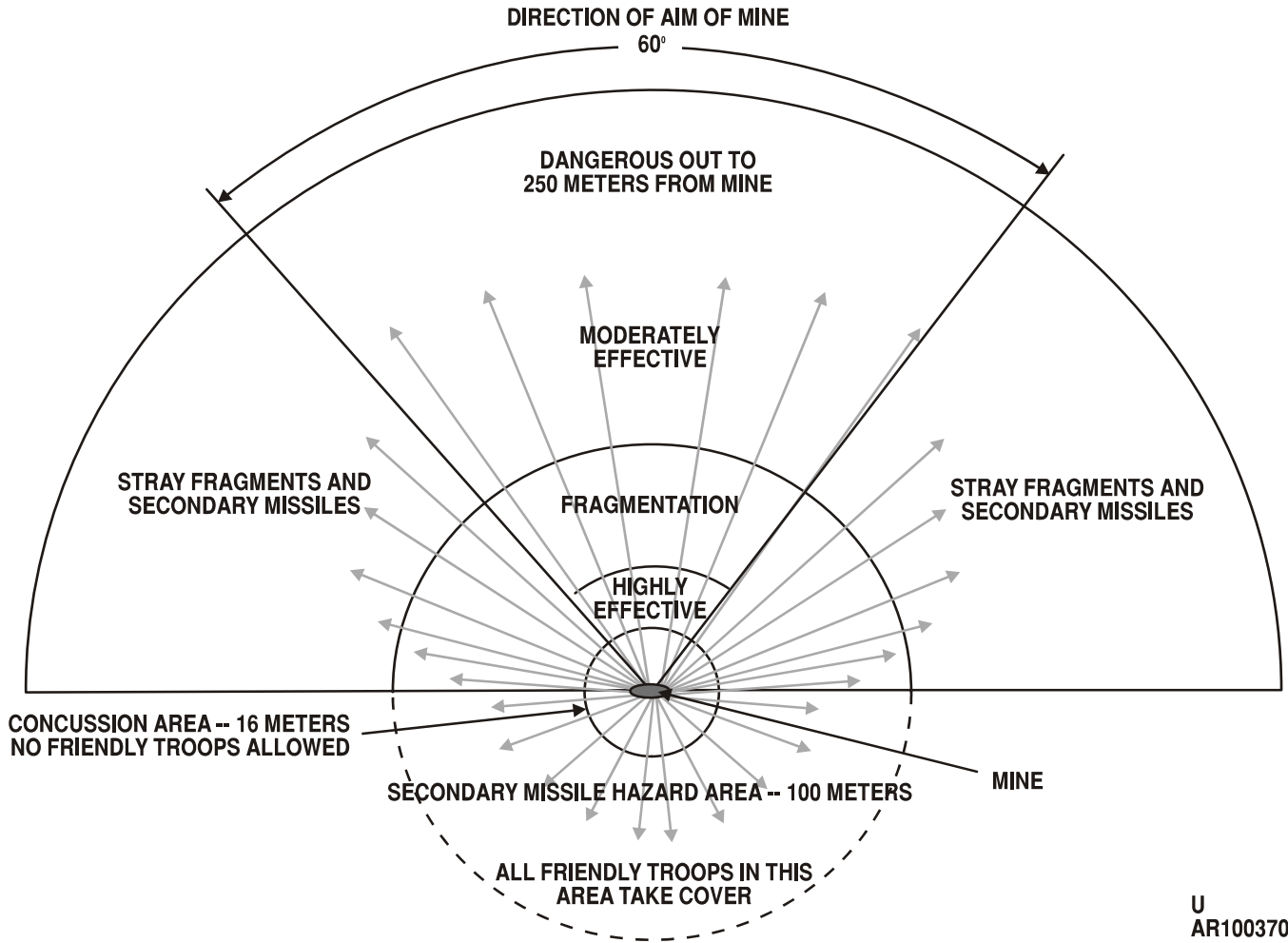

Figure 2-9. Casualty and danger areas of antipersonnel mine M18A1 with electric initiation system.

THIS PAGE INTENTIONALLY LEFT BLANK

To prevent tipping in windy areas or when the legs cannot be pressed into the ground, carefully spread legs to the maximum possible (approximately 180 degrees), so that the legs will be fore and aft.

- (1) Remove mine and accessories from bandoleer. Read instruction sheet attached to flap of bandoleer.

**WARNING**

**POSITION MINE SO THAT FRIENDLY TROOPS TO REAR AND SIDE OF MINE (FIG. 2-9) WILL NOT BE ENDANGERED. FIRING POSITION SHOULD BE AT LEAST 16 METERS TO REAR OR SIDES OF MINE.**

- (2) Turn legs downward and spread about 45-degrees. Twist legs so that one protrudes ahead of the mine; the other, behind mine. Position mine with surface marked FRONT TOWARD ENEMY and arrows on top of case pointing in direction of enemy or desired area of fire.

c. *Aiming.*

- (1) *For mines with slit-type peepsight:*

- (a) Select aiming object (tree, bush, etc.) or use aiming stake that is approximately 8 feet above ground.
- (b) Position eye approximately 6 inches away from mine. Aim mine by sighting slit-type peepsight.

**NOTE**

Groove of sight should be in line with aiming point. Aiming object should be in center of desired coverage area. Bottom edge of peepsight should be parallel to ground to be covered with fragment spray.

- (2) *Mines with knife-edge sight (fig. 2-10):*

- (a) Select a point approximately 50 meters in front of the mine at ground level.
- (b) Position eye approximately 6 inches to the rear of the sight. Aim mine by aligning two edges of sight with aiming point.

d. *Arming, Testing, and Electrical Firing.*

**WARNING**

**MINE M18A1 WILL BE PREPARED FOR NON-ELECTRIC DETONATION IF THERE IS A POSSIBILITY OF SPONTANEOUS INITIATION DURING ELECTRIC STORMS WHICH COULD ENDANGER FRIENDLY TROOPS. KEEP TROOPS AWAY FROM BLAST. REFER TO FM 5-250.**

- (1) Unscrew either right or left shipping plug priming adapter, and reverse it to allow firing wire to be placed into slot provided in primary adapter portion (fig. 2-8).
- (2) Remove tape and unroll paper form, or plastic spool, from electric blasting cap assembly (fig. 2-11). Retain plastic spool or paper form and tape for possible future use. Hold blasting cap while unwinding approximately 3 meters of firing wire.

**CAUTION**

ASSURE THAT COMBINATION SHORTING PLUG AND DUST COVER IS ASSEMBLED TO CONNECTOR OF BLASTING CAP ASSEMBLY BEFORE PLACING CAP IN DETONATOR WELL.

**NOTE**

Assure that firing wire is uncoiled without tangling or kinking.

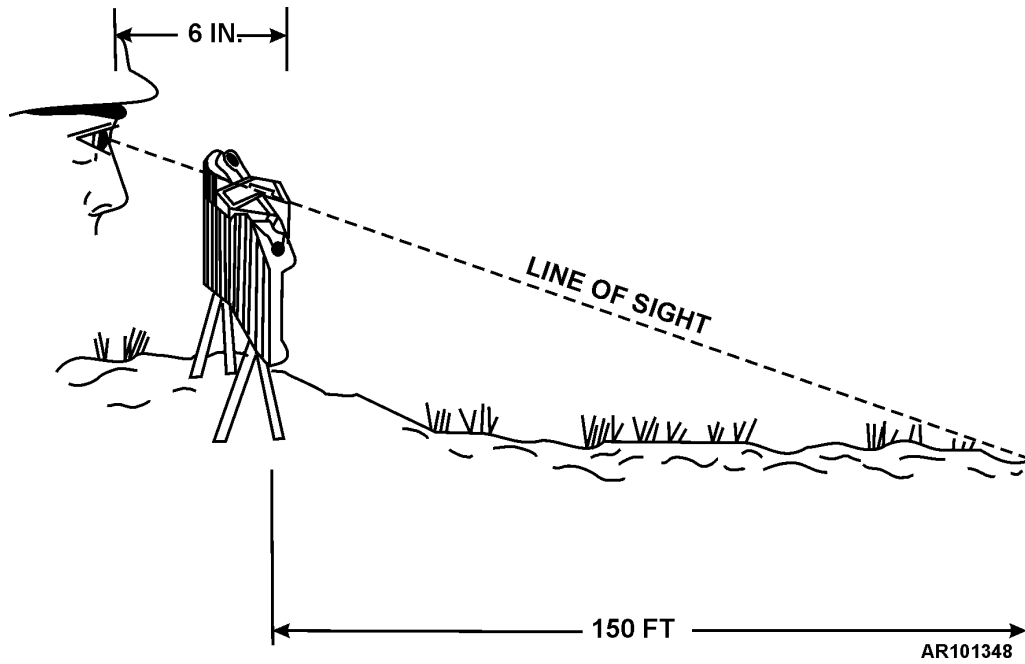

Figure 2-10. Aiming antipersonnel mine M18A1 with electric initiation system (equipped with knife-edge sight).

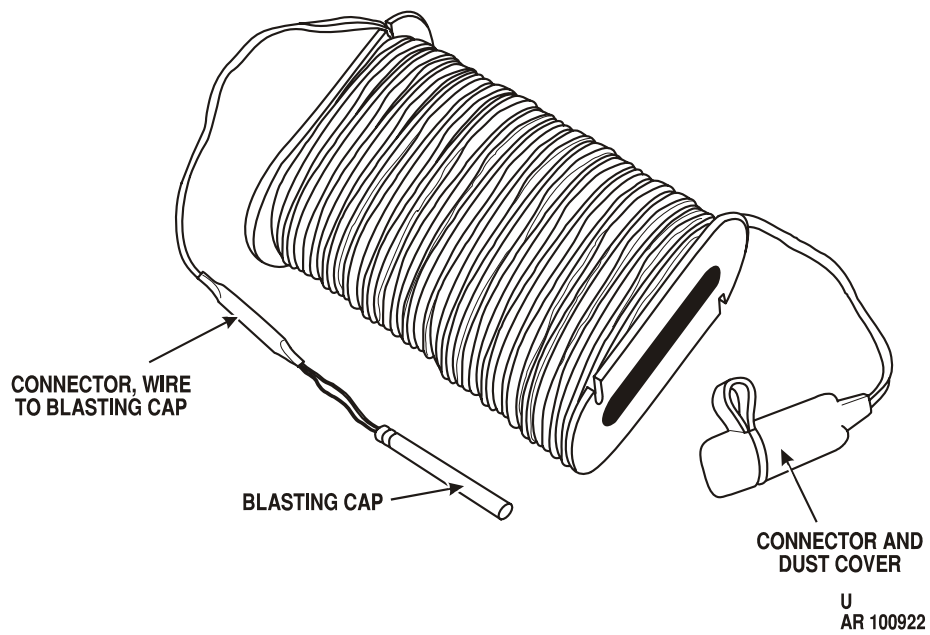

Figure 2-11. Electric blasting cap assembly M4, with blasting cap M6.

b. *Laying.*

**NOTE**

- (3) Wind firing wire around a stake located approximately 1 meter from same side of mine as detonator well to prevent mine from being misaligned if firing wire is disturbed.

**WARNING**

**A CONTINUITY TEST OF FIRING CIRCUIT SHOULD BE CONDUCTED BEFORE BLASTING CAP IS PLACED INTO DETONATOR WELL (PARA (10)).**

**OPERATOR WILL RETAIN POSSESSION OF M57 FIRING DEVICE AT ALL TIMES DURING LAYING OF MINE AND TESTING OF FIRING CIRCUIT. THIS PREVENTS ACCIDENTAL FIRING BY A SECOND INDIVIDUAL.**

**ASSURE THAT FACE OF MINE MARKED "FRONT TOWARD ENEMY" AND ARROW ON TOP OF MINE POINT IN DIRECTION OF ENEMY.**

**NOTE**

There are two methods for arming a mine, one for mines manufactured prior to 1972 and another for mines manufactured after 1972.

- (4) For mines manufactured prior to 1972:
  - (a) Slide slotted end of shipping plug priming adapter on firing wires of blasting cap between crimped connections and blasting cap.
  - (b) Pull excess wire through slotted end of shipping plug priming adapter until top of blasting cap is firmly seated in bottom portion of shipping plug priming adapter.
  - (c) Screw shipping plug priming adapter and blasting cap into detonator well.
  - (d) Recheck aim of mine to assure mine has not been disarranged.

- (5) Mines manufactured after 1972 have a rubber insulated spool wire extending into the blasting cap of the M4 assembly and no connector. These mines require a different arming procedure as follows:

- (a) Slide rubber covered wire (approximately 6 in. above the cap) into slotted end of shipping plug priming adapter with slight pressure.
  - (b) Pull up on excess wire through slotted end of shipping plug priming adapter until top of blasting cap is firmly seated in bottom portion of shipping plug priming adapter.
  - (c) Then, screw shipping plug priming adapter and blasting cap into detonator well.
  - (d) Recheck aim of mine to assure mine has not been disarranged. This procedure should also be used with M10 Blasting Cap Assembly which has connector on it. (This assembly is used with M68 Inert Mine.)
- (6) Unwind remaining firing wire to firing position. If possible, bury firing wire to protect it from artillery fire and to prevent easy detection. Camouflage the mine. Examples of setup are shown in figure 2-12.

**WARNING**

**MINE FIRING POSITION SHOULD BE LOCATED IN A CLEARED FOXHOLE, A SHIELDED OR PROTECTED POSITION, OR AT LEAST 16 METERS BEHIND OR TO SIDE OF EMPLACED MINE.**

**FIRING DEVICE SHOULD NOT BE CONNECTED TO THE FIRING WIRE UNTIL THE ACTUAL TIME OF FIRING.**

**CAUTION**

**SINGLE HEARING PROTECTION IS REQUIRED FOR ALL PERSONNEL WITHIN 300 FEET (90 M) OF A DETONATING M18A1 AP MINE.**

**NOTE**

Retain paper roll form or plastic spool for future use during disarming.

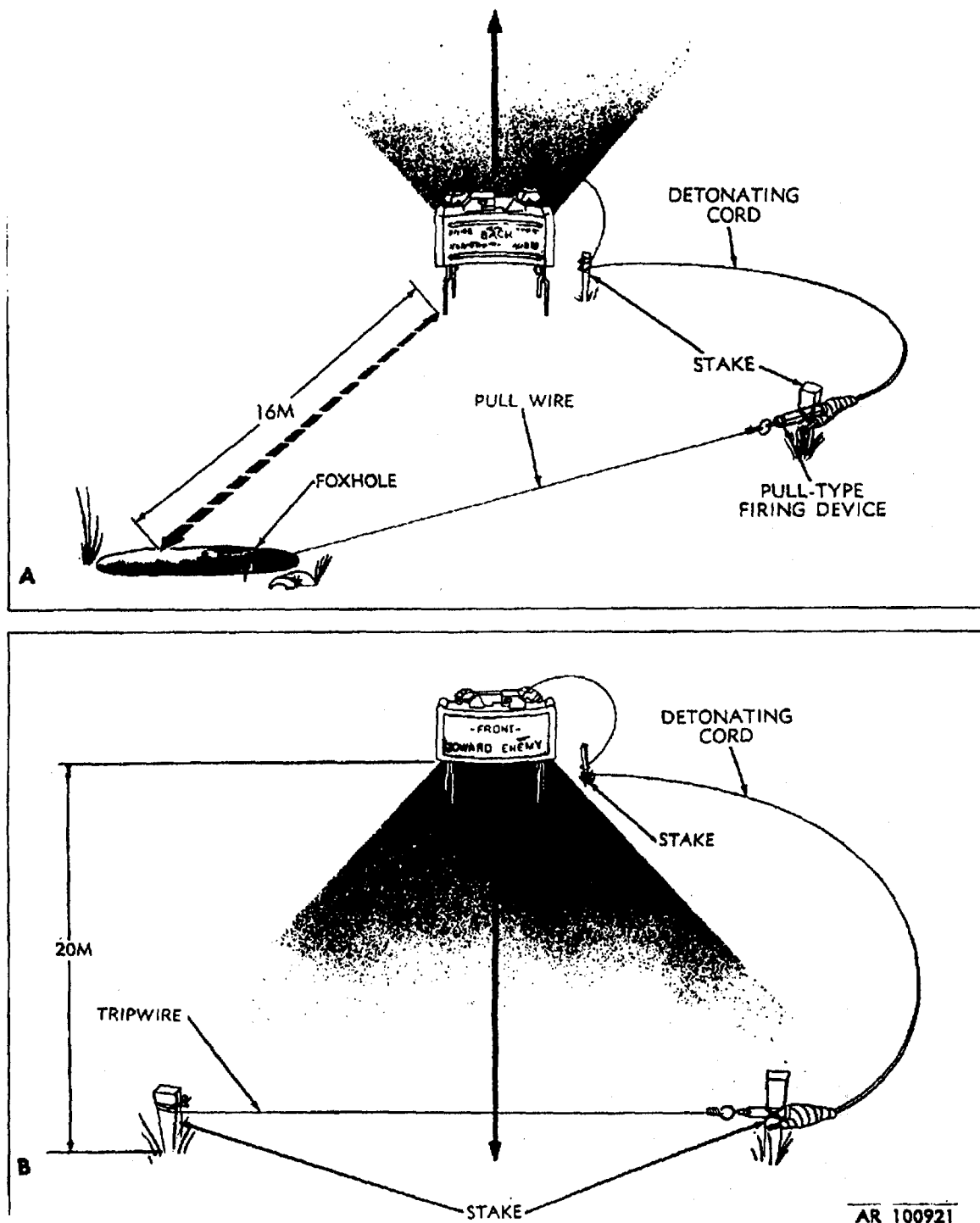

Figure 2-12. Mine M18A1 set up for nonelectric detonation.

- (7) Remove dust cover from connector on firing device; also remove combination shorting plug and dust cover from end of firing wire. Plug into the two connectors to connect firing wire to firing device.

**WARNING**  
**BEFORE CONNECTING BLASTING CAP TO FIRING DEVICE (FIG. 2-8), SAFETY BAIL MUST BE IN "SAFE" POSITION AND ALL PERSONNEL WHO ARE WITHIN 250 METERS OF FRONT AND SIDES OF MINE AND 100 METERS OF REAR OF MINE MUST BE UNDER COVER.**

- (8) To fire mine, position firing device bail in "fire" position.

**NOTE**  
**When enemy troops approach within 20 to 30 meters of front of mine, fire mine.**

- (9) Fire by actuating firing device handle with a firm, quick squeeze, then release.

**WARNING**  
**THE M57 FIRING DEVICE MAY NOT BE SAFE IF HANDLE IS DEPRESSED OR SUSTAINS A SHARP IMPACT, EVEN WITH BAIL UP IN "SAFE" POSITION, WHEN IT IS CONNECTED TO THE FIRING CIRCUIT. MOVEMENT OF HANDLE CAN PRODUCE ELECTRICAL ENERGY AND PREMATURE MINE DETONATION. THIS EFFECT MAY BE INTERMITTENT AND IT VARIES BETWEEN AND AMONG M57 LOTS.**

- (10) The detailed circuit testing procedure is as follows: Test M57 Firing Device and M4 Blasting Cap Assembly before inserting M6 cap into mine detonator well. If an extended period of time elapses between circuit test and insertion of blasting cap

into detonator well, or if the area is subjected to artillery or mortar fire, another test should be conducted, as indicated in (a) through (h) below.

**CAUTION**  
**BEFORE AND AFTER COMPLETION OF FIRING DEVICE AND BLASTING CAP CONTINUITY TESTS, ASSURE THAT FIRING DEVICE BAIL IS IN "SAFE" POSITION.**

**NOTE**

- If time available precludes conduct of a circuit test with blasting cap removed from mine, then an abbreviated test may be conducted with blasting cap inserted into detonator well. If an abbreviated test is conducted, all personnel must be under cover at least 250 meters from front and sides of mine and 100 meters to rear of mine.

- One M40 test set is provided with each case of six M18A1's. The test set (fig. 2-8) is an instrument used for checking continuity of electrical firing circuit, including M57 firing device. A shipping tag on carrying strap marks bandoleer which contains test set.

- (a) Remove dust cover from connector of firing device and from female connector of M40 test set.
- (b) Plug test set into firing device (fig. 2-8). Leave combination shorting plug and dust cover assembled on other end of test set.
- (c) Position firing device bail to "fire" position, actuate handle of firing device with a firm, quick squeeze, and observe flashing of lamp through test set window.

**NOTE**

Window of test set should be held near eye when checking firing device and blasting cap assembly. This minimizes risk of the enemy observation in dark and improves ability of operator to see lamp flashing even in bright sunlight.

- (d) Flashing of lamp indicates that firing device is functioning properly. If lamp does not flash, firing device or test set should be discarded and replaced with another firing device or test set. After completion of firing test, assure that device bail is in "safe" position.

**WARNING**

**BEFORE CONNECTING BLASTING CAP TO TEST SET AND FIRING DEVICE (FIG. 2-8), SAFETY BAIL MUST BE IN "SAFE" POSITION, AND ALL PERSONNEL WHO ARE WITHIN 250 METERS OF FRONT AND SIDES OF MINE AND 100 METERS OF REAR OF MINE MUST BE UNDER COVER.**

**NOTE**

If test set indicates that more than one firing device is faulty, retest with another test set prior to discarding the firing device, as test set may be defective.

- (e) Remove shorting plug and dust cover from connector of blasting cap and from end of test set. Plug connector of blasting cap into test set. Position firing device bail to "fire" position. Actuate handle with a firm quick squeeze, then release.

- (f) Flashing of test set lamp indicates that blasting cap continuity is satisfactory. If lamp does not flash, determine if there is evidence of a break in the firing wire within 6 inches of blasting cap.
- (g) If there is no evidence of a break in firing wire within 6 inches of blasting cap, replace blasting cap and test again for serviceability as indicated in (e) above.
- (h) If there is evidence of a break in firing wire within 6 inches of blasting cap, replace blasting cap as indicated in 1 through 7 below.

**WARNING**

**BEFORE REPLACING BLASTING CAP, DISCONNECT FIRING WIRE FROM TEST SET AND REINSTALL SHORTING PLUG IN TEST SET AND AT END OF FIRING WIRE.**

- 1 Using wire cutters, cut both strands of rubber-coated wire, as close as possible to blasting cap, at a point between break in wire and shorting plug end. Dispose of blasting cap in accordance with local explosive ordnance disposal procedures.
- 2 Using stripping portion of wire cutters, cut and pull apart (separate) both strands of wire for a distance of approximately 4 inches and remove 1/2 inch of insulation material from ends.
- 3 Unroll wire of blasting cap M6 from cardboard shipping spool. Place blasting cap behind barricade or protective device and remove short-circuiting tab from the wire.



- 4 Using lead wire from blasting cap, bend approximately 1/2 inch of bare wire at the end at right angles. Repeat procedure using lead wire as in 2 above. Place bent portions of both wires together with ends pointing in same direction. Twist wires together, making four or five turns.
- 5 Connect and tape remaining lead wires in similar manner.
- 6 Cover both taped connections with layer of electrical insulation tape.
- 7 Again, test blasting cap continuity as indicated in (e) above.

e. *Arming and Non-Electric Firing.* Instructions for laying, aiming and arming using two non-electric blasting caps M7, a piece of detonating cord approximately 25 feet long, a pull-wire, and a pull-type or pull-friction type firing device such as M1 or M3 are outlined below.

**NOTE**

To arm mine by methods below, a thorough knowledge of use of explosives and demolition materials and use and installation of land mines and boobytraps is required. Refer to FM 5-250, FM 5-31, and TM 9-1375-213-12.

- (1) *For pull-wire initiation:*
  - (a) Laying and aiming mine are performed in same manner as that used for electric firing. Refer to b and c above for laying and aiming.
  - (b) Crimp a blasting cap M7 to a pull-type device, using cap crimping pliers M2 (with fuze cutter) for this operation.
  - (c) Fasten one end of detonating cord to blasting cap that is attached to firing device ((b) above) by means of tape (fig. 2-12, view A).

- (d) Fasten firing device securely to a firmly emplaced stake (fig 2-12, view A) by means of tape, wire, twine, or anchor cord.
- (e) Slip slotted end of the shipping plug priming adapter over other end of the detonating cord.
- (f) Insert detonating cord end fully into second blasting cap. Crimp cap to detonating cord, using cap crimping pliers M2 for this operation.
- (g) Seat cap (with detonating cord) in shipping plug priming adapter and carefully insert cap into well.
- (h) Secure the cap in well by carefully screwing shipping plug priming adapter into detonator well.
- (i) Attach pull-wire securely to pull ring of firing device. Pull-wire should be of sufficient length to allow actuation of firing device from a protected position at least 16 meters rearward (minimum safe distance protected position) from emplaced mine (fig. 2-12, view A).

**WARNING**

**CARE MUST BE TAKEN DURING EMPLACEMENT TO SECURE FIRING DEVICE SO THAT MINE WILL NOT BE DISLODGED BY A PULL OF DETONATING CORD OR TRIPWIRE. IF MINE BECOMES DISLODGED, THEREBY AFFECTING AIMING, IT WILL BE AIMED IN A DIRECTION OTHER THAN INTENDED.**

- (2) *For tripwire initiation:*
  - (a) Perform laying and aiming of mine in same manner as that used for electric firing. Refer to b and c above for laying and aiming.
  - (b) Use same procedures used in (1)(a) through (h) above for preliminary steps to arm mine.

- (c) Stretch tripwire across a trail or other avenue of approach, and securely attach firing device to two firmly emplaced stakes at a distance of approximately 20 meters forward of mine (fig. 2-12, view B).

(3) *For detonation cord procedure:*

**NOTE**

These components are not provided with the M18A1 and are requisitioned separately.

(a) *Dual firing.*

- 1 Obtain two 10-meter (33 ft) lengths of detonating cord, four non-electric blasting caps M7, and two pull-type firing devices.
- 2 Remove both shipping plug priming adapters from mine. Push one end of each piece of detonating cord through holes in the adapters.

**NOTE**

Push cord through holes far enough to allow blasting caps to be crimped to the cords ends.

- 3 Crimp end of each piece of detonating cord to a blasting cap M7, using cap crimper M2. Pull excess of detonating cord through holes in adapters so that blasting caps seat against the bottom of the adapters.
- 4 Screw shipping plug priming adapters into detonator wells. Unwind detonating cord while moving back to safe firing distance.
- 5 Emplace mine and detonating cord as instructed in e(1)(a) to (h) above, and as shown in figure 2-12.
- 6 Attach a pull-type firing device (refer to FM 5-250) to free end of each piece of detonating cord, and attach a pull-wire or tripwire as instructed in e(1) or (2) above.

(b) *Dual priming.*

- 1 Follow the instructions in (a)1 through 5 above.
- 2 Make a ring main in accordance with instructions contained in FM 5-250.
- 3 When emplaced one behind the other, the foremost mine (nearest enemy) must be fired first.

f. *Simultaneous Firing of More than One Mine.*

**NOTE**

Mines may be set up for dual firing and/or dual priming, using standard demolition procedures in FM 5-250.

A system for firing simultaneously various numbers of mines M18A1 can be set up using materials described below and standard demolitions procedures in FM 5-250.

(1) *Electrical firing.*

(a) *Materials required.*

- 1 Cap, blasting: special, electric, M6.
- 2 Blasting machine: M32, 10-cap capacity (or blasting machine: 50-cap capacity).
- 3 Wire, No. 18 AWG, two-conductor, plastic-covered or rubber-covered type.
- 4 Wire, No. 20 AG, single conductor.
- 5 Reel unit RL39A.

- (b) *Procedure.* When using 10-cap (or 50-cap) capacity blasting machine M32, connect up to 10 (or 50) blasting caps in series, using a maximum of 500 feet of two-conductor, insulated No. 18 copper firing cable. Blasting caps M6 will be connected to mines M18A1 using shipping plug priming adapter. Standard demolition procedures in FM 5-250 will be used in making all electrical connections.

(2) *Non-electric firing.*

(a) *Materials required.*

- 1 Cap, blasting: special, non-electric, M7.
- 2 Cord, detonating: fuze, primacord.
- 3 Fuze lighter, M60.
- 4 Blasting time fuze (M700).

(b) *Procedure.* Two or more mines M18A1 can be fired simultaneously using above materials. Blasting caps M7 will be connected to mines M18A1 using shipping plug priming adapter. Standard demolition procedures in FM 5-250 will be used in making all non-electric connections. Mines emplaced side-to-side in a line may be fired in any order simultaneously. Mine and the danger area around the mine must be visible from firing position so that any friendly personnel in the vicinity of the mine may be seen.

**WARNING**

**A DISLODGED OR OVERTURNED MINE IS A POTENTIAL HAZARD TO FRIENDLY PERSONNEL AND SHOULD NOT BE FIRED.**

g. *Disarming and Destruction.*

**CAUTION**

RENDER FIRING DEVICE SAFE BY RETURNING SAFETY BAIL (fig. 2-8) TO THE SAFE POSITION PRIOR TO PERFORMING THE STEPS BELOW. DUDS OR MINES WHICH APPEAR TO HAVE BEEN RUN OVER BY A VEHICLE OR OTHERWISE DAMAGED AFTER EMPLACEMENT SHOULD BE CONSIDERED UNSAFE. DESTROY THEM AS OUTLINED IN (2) BELOW.

(1) *Disarming.*

(a) *Mine with electrical components.*

- 1 Disconnect firing wire from firing device. Replace combination shorting plug and dust cover on blasting cap assembly connector, and dust cover on firing device connector.
- 2 Unscrew and remove shipping plug priming adapter (fig. 2-8) containing blasting cap from mine. Remove blasting cap and firing wire from shipping plug priming adapter.

- 3 Reverse shipping plug priming adapter and screw plug end of shipping plug priming adapter into mine.
- 4 Remove firing wire from stake beneath mine or around mine leg. Reroll blasting cap and firing wire on plastic spool and secure this assembly with piece of insulation tape.
- 5 Remove mine from its emplacement and repack mine and its accessories in their respective pocket in bandoleer.

**NOTE**

Assure that all accessories are removed from mine before repacking.

(b) *Mine with non-electric components.*

**CAUTION**

ASSURE THAT FIRING DEVICE HAS NOT BEEN FIRED OR MINE RUN OVER. IF BLASTING CAP HAS FIRED OR MINE APPEARS TO BE A DUD, DESTROY MINE. RENDER FIRING DEVICE SAFE BY REPLACING ALL SAFETY PINS PRIOR TO PERFORMING STEPS BELOW. NON-ELECTRIC BLASTING CAPS AND DETONATING CORD CRIMPED TOGETHER CAN BE SEPARATED ONLY BY CUTTING BLASTING CAP FREE OF DETONATING CORD USING A NONSPARKING KNIFE. IF FACILITIES ARE NOT AVAILABLE FOR CUTTING BLASTING CAP FREE OF DETONATING CORD, AND THESE COMPONENTS ARE NOT TO REUSED IMMEDIATELY, THE CRIMPED EXPLOSIVE COMPONENTS SHOULD BE DESTROYED IN ACCORDANCE WITH INSTRUCTIONS CONTAINED IN AR 385-64, DA PAM 385-64, AND TM 9-1345-213-12.

- 1 Disconnect pull-wire or tripwire from firing device.
- 2 Unscrew and remove shipping plug priming adapters containing blasting caps from mine. Using a nonsparking knife, cut blasting cap free of detonating cord.
- 3 Blasting cap should be destroyed. Pull detonating cord end free of shipping plug priming adapters and discard.

- 4 Reverse shipping plug priming adapter and screw it in detonator well, plug end down.
  - 5 Remove mine from its emplacement position and repack. Store accessory items in original or appropriate containers.
- (2) *Destruction.* Any mine considered a dud or otherwise in an unsafe condition should not be handled or jarred, but should be destroyed as instructed in AR 385-64 and DA Pam 385-64.
- h. *Preparation of Long Term Emplacement.*
- (1) Preparation of the mine M18A1 for long term emplacement shall follow the same procedure outlined in the manual except that a heavy coating of silicone grease shall be applied to the blasting cap just before it is inserted into the detonator well.
  - (2) Emplacement life of mine M18A1, calculated to 70% effectivity, is 240 months for all environments.

THIS PAGE INTENTIONALLY LEFT BLANK

**2-3.1 Mine, Antipersonnel: M18A1, with Non-Electric Initiation System (Figure 2-12.1)**

and 60-degrees wide at a range of 50 meters (fig. 2-12.2). These balls are effective up to a range of 100 meters and are dangerous up to 250 meters in front of the mine.

a. *Casualty Effect and Danger Area.*

(1) *Fragmentation.* Mine M18A1 delivers 700 steel balls in a fan-shaped pattern approximately 2 meters high

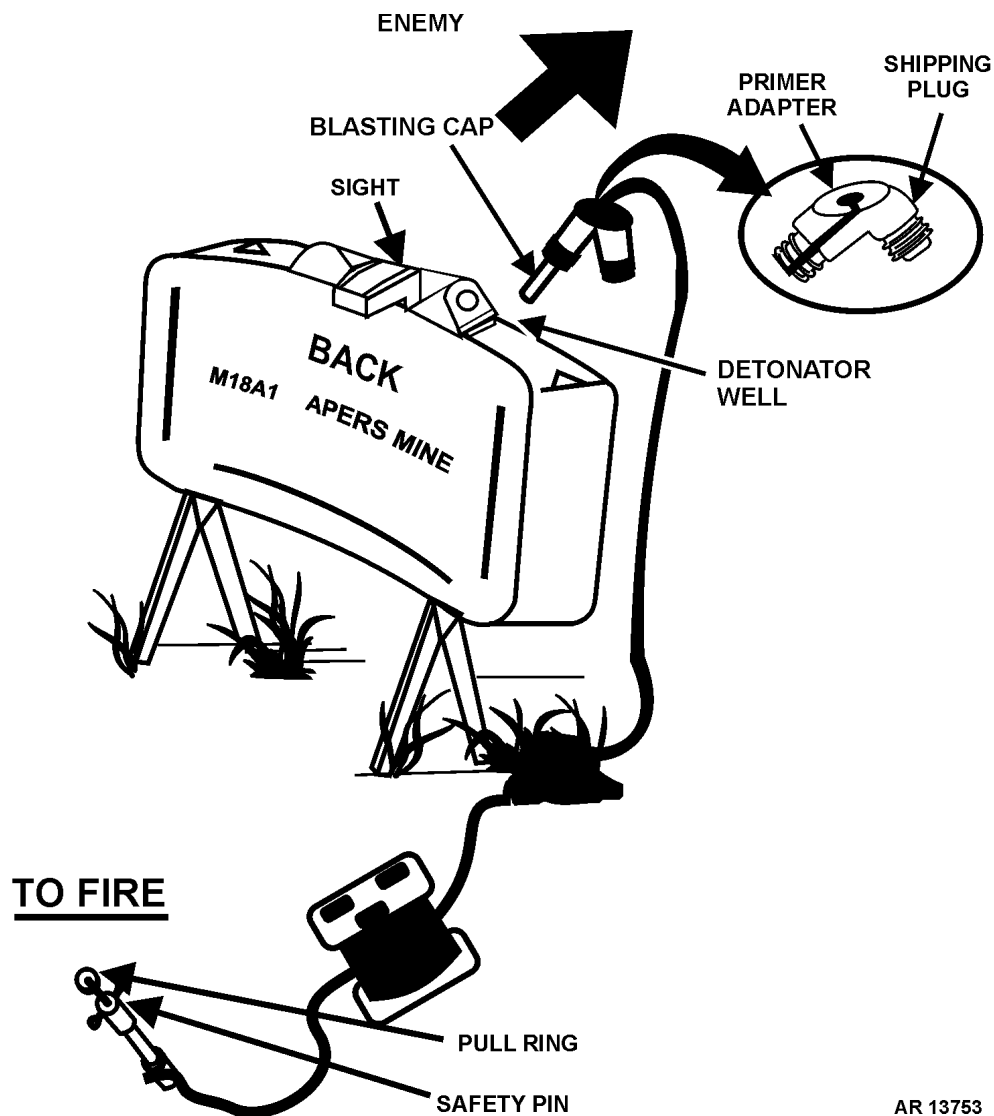

AR 13753

Figure 2-12.1. Mine, antipersonnel: M18A1, with non-electric initiation system.

(2) *Backblast.* Within an area of 16 meters (figure 2-12.2) to the rear and sides of the mine, backblast can cause injury by concussion and secondary missiles. Up to 100 meters to rear and sides of mine, all friendly personnel must be under cover for protection from secondary missiles.

(a) *Radius of 0 to 16 meters from mine.* Friendly troops are prohibited in this area.

(b) *Radius of 16 to 100 meters from mine.* Minimum safe operating distance from mine is 16 meters. At this distance, the operator should be in a foxhole or dugout or should lie prone, preferably in a depression. All friendly troops, including operator, within 100 meters of mine should take cover behind a boulder, tree, or similar shelter to prevent being injured by flying secondary missiles, sticks, stones, pebbles, etc.

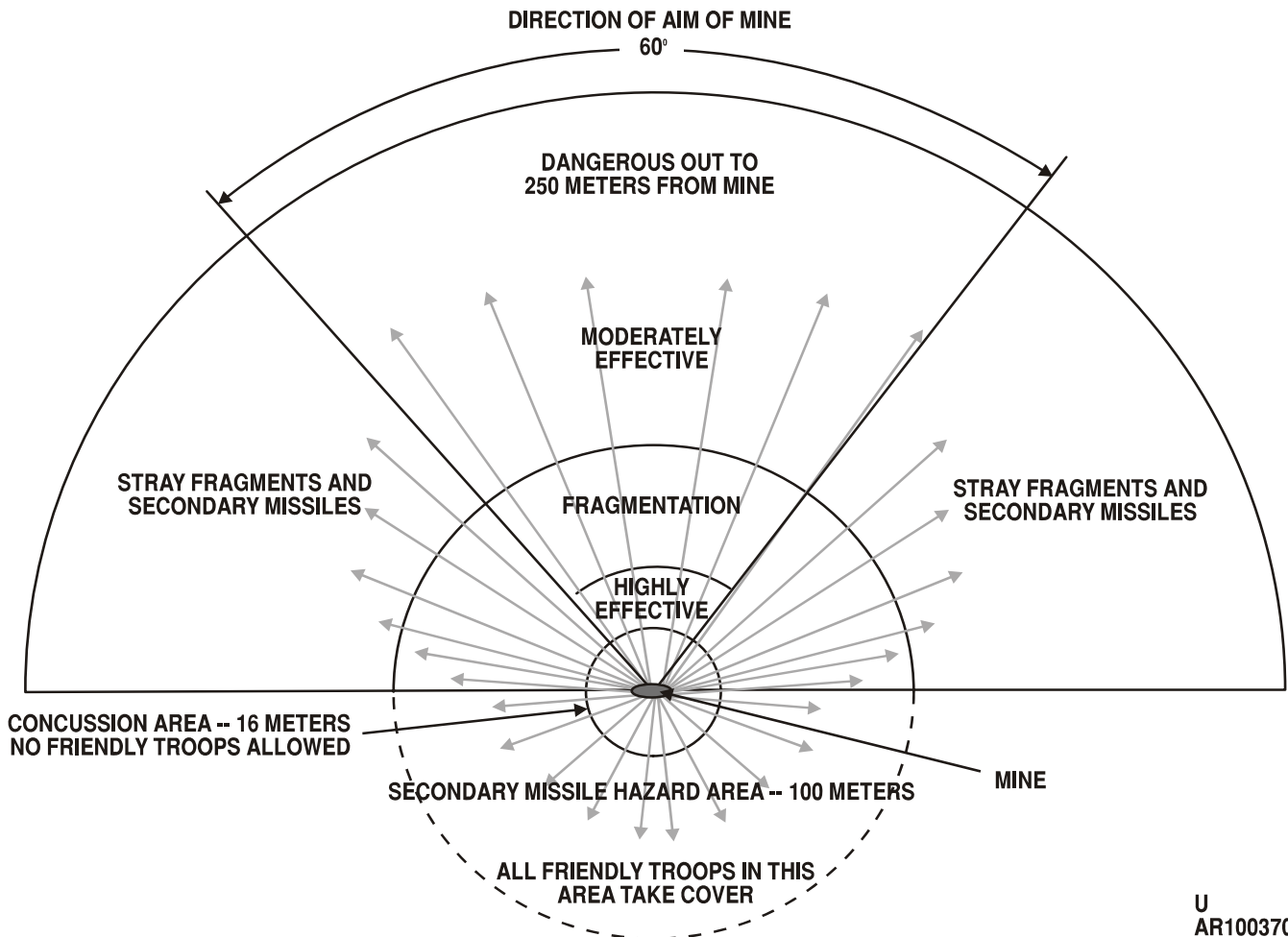

Figure 2-12.2. Casualty and danger areas of antipersonnel mine M18A1 with non-electric initiation system.

b. *Laying.***NOTE**

To prevent tipping in windy areas or when the legs cannot be pressed into the ground, carefully spread legs to the maximum possible (approximately 180 degrees), so that the legs will be fore and aft.

- (1) Remove mine and accessories from bandoleer. Read instruction sheet attached to flap of bandoleer.

**WARNING**

**POSITION MINE SO THAT FRIENDLY TROOPS TO REAR AND SIDE OF MINE (FIG. 2-12.2) WILL NOT BE ENDANGERED. FIRING POSITION SHOULD BE AT LEAST 16 METERS TO REAR OR SIDES OF MINE.**

- (2) Turn legs downward and spread about 45-degrees. Twist legs so that one protrudes ahead of the mine; the other, behind mine. Position mine with surface marked FRONT TOWARD ENEMY and arrows on top of case pointing in direction of enemy or desired area of fire.

c. *Aiming of Mines with Knife-edge Sight (fig. 2-12.3).*

- (1) Select a point approximately 50 meters in front of the mine at ground level.
- (2) Position eye approximately 6 inches to the rear of the sight. Aim mine by aligning two edges of sight with aiming point.

d. *Arming of Non-Electric Initiation System and Firing.*

- (1) Unscrew either right or left shipping plug priming adapter, and reverse it to allow shock tube to be placed into slot provided in primary adapter portion (fig. 2-12.1).
- (2) Remove tape and unspool shock tube from plastic spool beginning from blasting cap assembly (fig. 2-12.4). Hold blasting cap while unwinding approximately 3 meters of shock tube.

**NOTE**

Assure that shock tube is uncoiled without tangling or kinking.

- (3) Secure shock tube approximately 18 inches from the blasting cap side of the mine with a stone, gravel, or sand bag to prevent mine from being misaligned if shock tube is disturbed.

**WARNING**

**OPERATOR WILL RETAIN POSSESSION OF THE SHOCK TUBE INITIATOR AT ALL TIMES DURING SETTING UP THE MINE AND UNSPOOLING THE SHOCK TUBE. THIS PREVENTS ACCIDENTAL FIRING BY A SECOND INDIVIDUAL.**

**ASSURE THAT FACE OF MINE MARKED "FRONT TOWARD ENEMY" AND ARROW ON TOP OF MINE POINT IN DIRECTION OF ENEMY.**

- (4) Unwind remaining shock tube to firing position. If possible, bury shock tube to protect it from artillery fire and to prevent easy detection. Camouflage the mine. Example of setup is shown in figure 2-12.1.



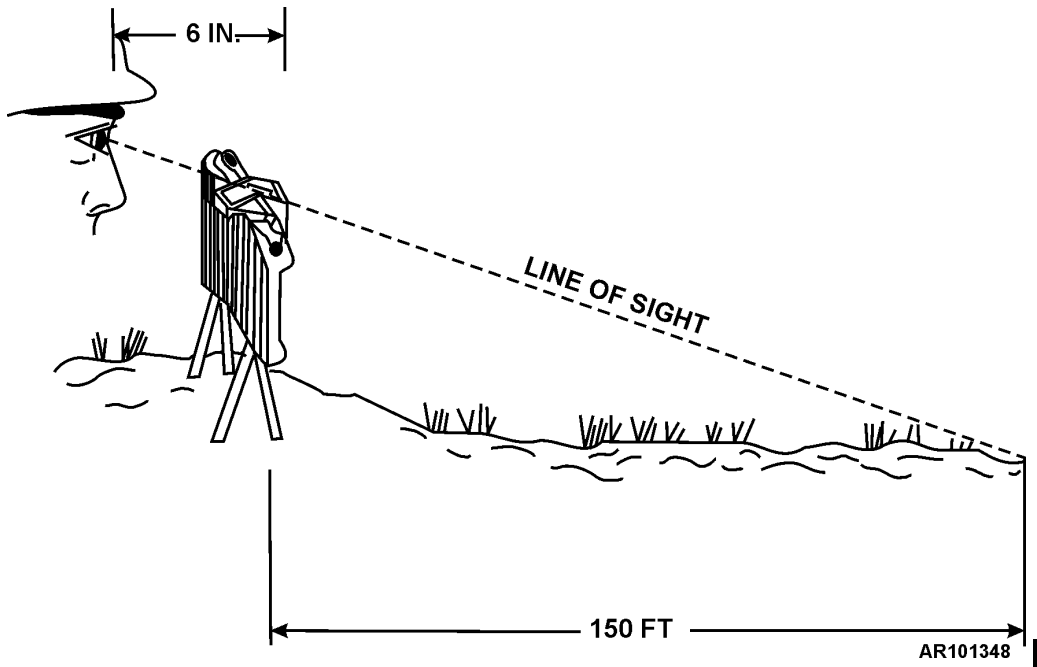

Figure 2-12.3. Aiming antipersonnel mine M18A1 with non-electric initiation system (equipped with knife-edge sight).

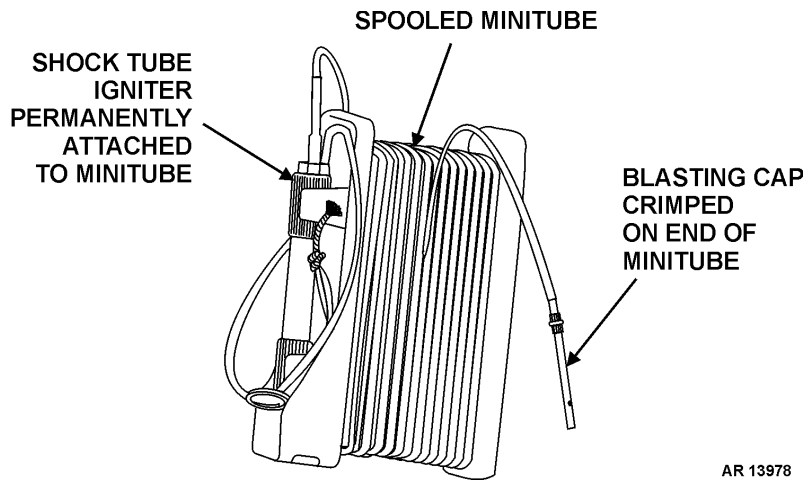

Figure 2-12.4. Non-electric blasting cap assembly with factory crimped blasting cap and permanently attached shock tube igniter.

**WARNING**

**MINE FIRING POSITION SHOULD BE LOCATED IN A CLEARED FOXHOLE, A SHIELDED OR PROTECTED POSITION, OR AT LEAST 16 METERS BEHIND OR TO SIDE OF EMPLACED MINE.**

**CAUTION**

SINGLE HEARING PROTECTION IS REQUIRED FOR ALL PERSONNEL WITHIN 300 FEET (90 M) OF A DETONATING M18A1 AP MINE.

DO NOT HOLD SHOCK TUBE WHEN FIRING CAPS.

**NOTE**

Retain plastic spool for future use during disarming, if necessary.

- (5) Hold igniter around body with one hand.

**WARNING**

**THERE IS A POSSIBILITY OF HOT GASEOUS BY-PRODUCTS BEING RELEASED FROM THE IGNITER FORWARD END OPENING (SHOCK TUBE INSERTION POINT) WHEN INITIATING THE MUNITION. DURING FIRING OF THE IGNITER, KEEP HANDS CLEAR OF THIS AREA.**

**NOTE**

When enemy troops approach within 20 to 30 meters in front of the mine, fire mine.

- (6) To fire, remove safety pin and retain for possible re-use later.
- (7) Pull ring sharply.

e. *Misfire Procedures.*(1) *Training Only.*

- (a) If the igniter is pulled and M18A1 AP Mine does not function, re-cock the shock tube igniter and attempt to fire again (shock tube igniter can be re-cocked twice).

**NOTE**

Re-cocking igniter may require a quarter turn to push ring all the way in.

- (b) Remove shock tube from shock tube igniter and measure approximately 3 feet (1 m) down the shock tube.

**WARNING**

**DO NOT INGEST OR INHALE EXPLOSIVE POWDER IN SHOCK TUBE. AFTER HANDLING SHOCK TUBE, WASH HANDS BEFORE EATING OR DRINKING.**

- (c) Cut the shock tube at measured point with knife (90° cut), being careful not to crimp the shock tube. Cut off an additional 6 inches of shock tube and conduct the blow test (blowing through the 6 inches with open end of shock tube in palm of hand).
- (d) If a small amount of silver powder exists, install a new shock tube igniter, if available, and attempt to fire.
- (e) If there is no silver powder in the palm of hand, repeat the 3 feet (1 m) measure cut and blow test that piece of shock tube until silver powder exists in palm of hand (this can be done two additional times or up to 9 feet (3 m)).

**WARNING**

**IF INITIATION OF THE M18A1 FAILS,  
WAIT 30 MINUTES BEFORE  
APPROACHING MUNITION.**

- (f) Install a new shock tube igniter, if available, and attempt to fire.
- (g) If the blasting cap assembly activates but the munition fails to function, the munition is considered to be a dud.
- (h) Flag for EOD disposal.

(2) *Operational Mission.*

- (a) If the shock tube igniter is pulled and M18A1 does not function, re-cock the shock tube igniter and attempt to fire again. Igniter can be re-cocked twice.

**NOTE**

Re-cocking igniter may require a quarter turn to push ring all the way in.

- (b) If there is an additional igniter and time permits, remove the original shock tube igniter and measure approximately 3 feet (1 m) down the shock tube.
- (c) Cut the shock tube at the measured point with shock tube cutter or knife (straight 90 degree cut), being careful not to crimp the shock tube. Install a new shock tube igniter, if available, and attempt to fire.
- (d) If additional igniter is not available, take control of the situation, flag the M18A1, and notify EOD for proper disposal.

f. *Disarming and Recovery.*

- (1) Remove safety pin (cotter pin) from anti-static bag in bandoleer.

- (2) Align hole in igniter with hole in pull ring shaft and insert safety pin through both holes.

g. *Arming and Non-Electric Firing.* Instructions for laying, aiming, and arming using two non-electric blasting caps M7, a piece of detonating cord approximately 25 feet long, a pull-wire, and a pull-type or pull-friction type firing device such as M1 or M3 are outlined below.

**NOTE**

To arm mine by methods below, a thorough knowledge of use of explosives and demolition materials and use and installation of land mines and boobytraps is required. Refer to FM 5-250, FM 5-31, and TM 9-1375-213-12.

(1) *For pull-wire initiation:*

- (a) Laying and aiming mine are performed in same manner as that used for electric firing. Refer to b and c above for laying and aiming.
- (b) Crimp a blasting cap M7 to a pull-type device, using cap crimping pliers M2 (with fuze cutter) for this operation.
- (c) Fasten one end of detonating cord to blasting cap that is attached to firing device ((b) above) by means of tape (fig. 2-12.5, view A).
- (d) Fasten firing device securely to a firmly emplaced stake (fig. 2-12.5, view A) by means of tape, wire, twine, or anchor cord.
- (e) Slip slotted end of the shipping plug priming adapter over other end of the detonating cord.
- (f) Insert detonating cord end fully into second blasting cap. Crimp cap to detonating cord, using cap crimping pliers M2 for this operation.
- (g) Seat cap (with detonating cord) in shipping plug priming adapter and carefully insert cap into well.
- (h) Secure the cap in well by carefully screwing shipping plug priming adapter into detonator well.

- (i) Attach pull-wire securely to pull ring of firing device. Pull-wire should be of sufficient length to allow actuation of firing device from a protected position at least 16 meters rearward (minimum safe distance protected position) from emplaced mine (fig. 2-12.5, view A).

**WARNING**

**CARE MUST BE TAKEN DURING EMPLACEMENT TO SECURE FIRING DEVICE SO THAT MINE WILL NOT BE DISLODGED BY A PULL OF DETONATING CORD OR TRIPWIRE. IF MINE BECOMES DISLODGED, THEREBY AFFECTING AIMING, IT WILL BE AIMED IN A DIRECTION OTHER THAN INTENDED.**

(2) *For tripwire initiation:*

- (a) Perform laying and aiming of mine in same manner as that used for electric firing. Refer to b and c above for laying and aiming.
- (b) Use same procedures used in (1)(a) through (h) above for preliminary steps to arm mine.
- (c) Stretch tripwire across a trail or other avenue of approach, and securely attach firing device to two firmly emplaced stakes at a distance of approximately 20 meters forward of the mine (fig. 2-12.5, view B).

(3) *For detonation cord procedure:*

**NOTE**

These components are not provided with the M18A1 and are requisitioned separately.

(a) *Dual firing.*

- 1 Obtain two 10-meter (33 ft) lengths of detonating cord, four non-electric blasting caps M7, and two pull-type firing devices.
- 2 Remove both shipping plug priming adapters from mine. Push one end of each piece of detonating cord through holes in the adapters.

**NOTE**

Push cord through holes far enough to allow blasting caps to be crimped to the cords ends.

- 3 Crimp end of each piece of detonating cord to a blasting cap M7, using cap crimper M2. Pull excess of detonating cord through holes in adapters so that blasting caps seat against the bottom of the adapters.
- 4 Screw shipping plug priming adapters into detonator wells. Unwind detonating cord while moving back to safe firing distance.
- 5 Emplace mine and detonating cord as instructed in e(1)(a) to (h) above, and as shown in figure 2-12.
- 6 Attach a pull-type firing device (refer to FM 5-250) to free end of each piece of detonating cord, and attach a pull-wire or tripwire as instructed in e(1) or (2) above.

(b) *Dual priming.*

- 1 Follow the instructions in (a) 1 through 5 above.
- 2 Make a ring main in accordance with instructions contained in FM 5-250.
- 3 When emplaced one behind the other, the foremost mine (nearest enemy) must be fired first.

h. *Simultaneous Firing of More than One Mine.*

**NOTE**

Mines may be set up for dual firing and/or dual priming, using standard demolition procedures in FM 5-250.

A system for firing simultaneously various numbers of mines M18A1 can be set up using materials described below and standard demolitions procedures in FM 5-250.

(1) *Non-Electric firing.*

(a) *Materials required.*

- 1 Cap, blasting: special, non-electric, M7.
- 2 Cord, detonating: fuze, primacord.
- 3 Fuze lighter, M60.
- 4 Blasting time fuze (M700).

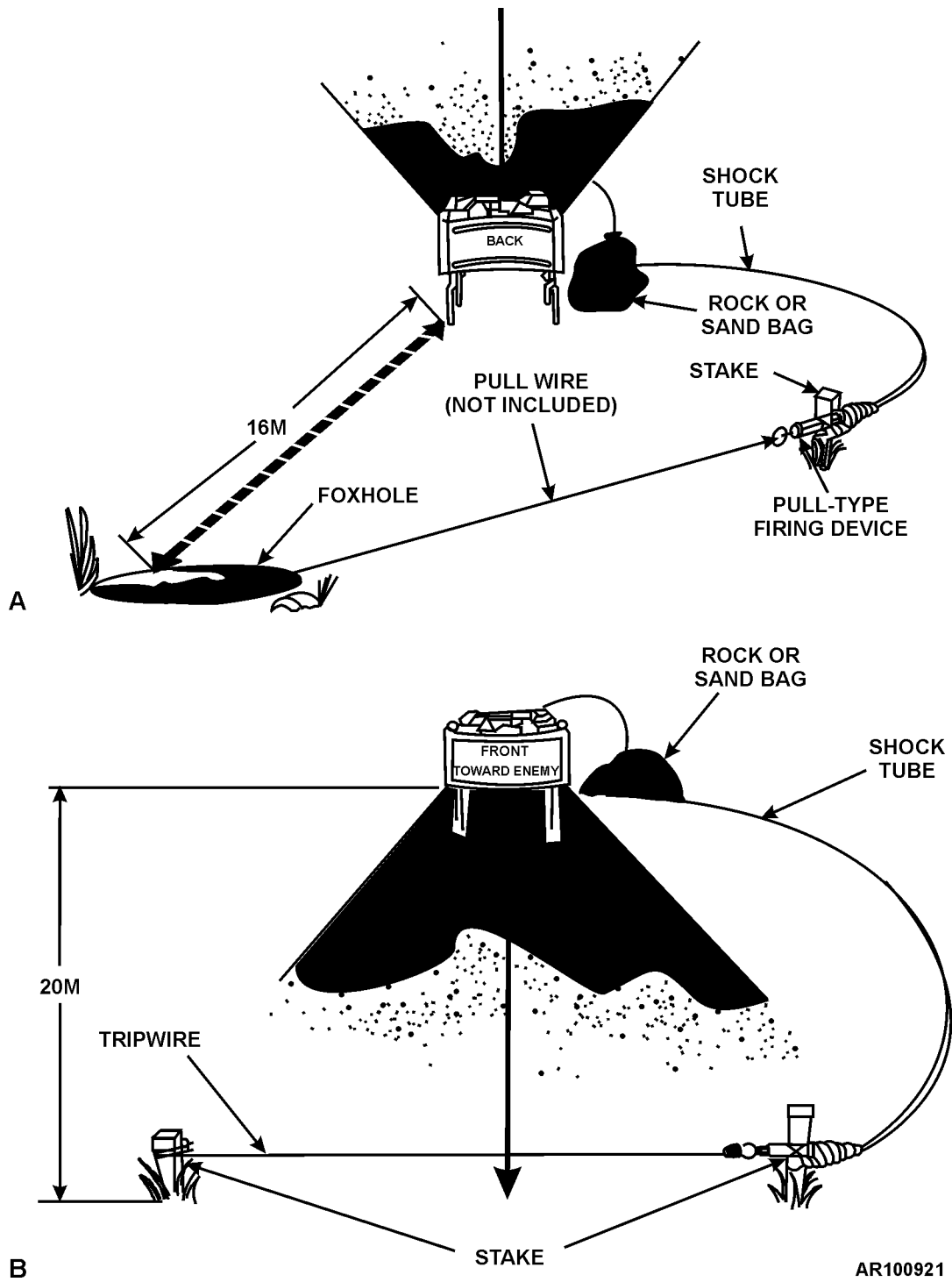

AR100921

Figure 2-12.5. Mine M18A1 set up for non-electric detonation with shock tube.

- (b) *Procedure.* Two or more mines M18A1 can be fired simultaneously using above materials. Blasting caps M7 will be connected to mines M18A1 using shipping plug priming adapter. Standard demolition procedures in FM 5-250 will be used in making all non-electric connections. Mines emplaced side-to-side in a line may be fired in any order simultaneously. Mine and the danger area around the mine must be visible from firing position so that any friendly personnel in vicinity of mine may be seen.

**WARNING**

**A DISLODGED OR OVERTURNED MINE IS A POTENTIAL HAZARD TO FRIENDLY PERSONNEL AND SHOULD NOT BE FIRED.**

- i. *Disarming and Destruction.*

**CAUTION**

ASSURE THAT FIRING DEVICE HAS NOT BEEN FIRED OR MINE RUN OVER. IF BLASTING CAP HAS FIRED OR MINE APPEARS TO BE A DUD, DESTROY MINE AS OUTLINED IN (2) BELOW. RENDER FIRING DEVICE SAFE BY REPLACING ALL SAFETY PINS PRIOR TO PERFORMING STEPS BELOW.

- (1) *Disarming.*

- (a) *Mine with non-electrical components.*

- 1 Disconnect pull-wire or tripwire from firing device.
- 2 Re-insert safety pin in shock tube igniter.

- 3 Unscrew and remove shipping plug priming adapters containing blasting caps from mine.
- 4 Blasting cap should be re-inserted into spool and shock tube should be re-spooled with igniter snapped back in it's holder on side of spool.

**NOTE**

Do not kink or crimp shock tube, as this will render it unusable.

- 5 Reverse shipping plug priming adapter and screw it in detonator well, plug end down.
- 6 Remove mine from its emplacement position and repack. Store accessory items in original or appropriate containers.

- (2) *Destruction.* Any mine considered a dud or otherwise in an unsafe condition should not be handled or jarred, but should be destroyed as instructed in AR 385-64 and DA Pam 385-64.

- j. *Preparation for Long Term Emplacement.*

- (1) Preparation of the mine M18A1 for long term emplacement shall follow the same procedure outlined in this manual except that a heavy coating of silicone grease shall be applied to the blasting cap just before it is inserted into the detonator well.
- (2) Emplacement life of mine M18A1, calculated to 70% effectivity, is 240 months for all environments.

THIS PAGE INTENTIONALLY LEFT BLANK

**2-4. Mine, Antipersonnel: M86 (Fig. 1-6)***a. Casualty effect and Danger area.*

- (1) Mine M86 is designed to project its fragments from a height of 6 inches to 8 feet above the ground.
- (2) The mine's fragmentation pattern is similar to a grenade.

*b. Inspection.*

- (1) Figure 2-13 shows removal of containers from PA19 wirebound wooden shipping box.
- (2) Remove barrier bag containing two mines in bandoleer from PA19 metal container in packing box. Inspect outer sealed barrier bag for complete seal.
- (3) Remove bandoleer with mines from sealed barrier bag.

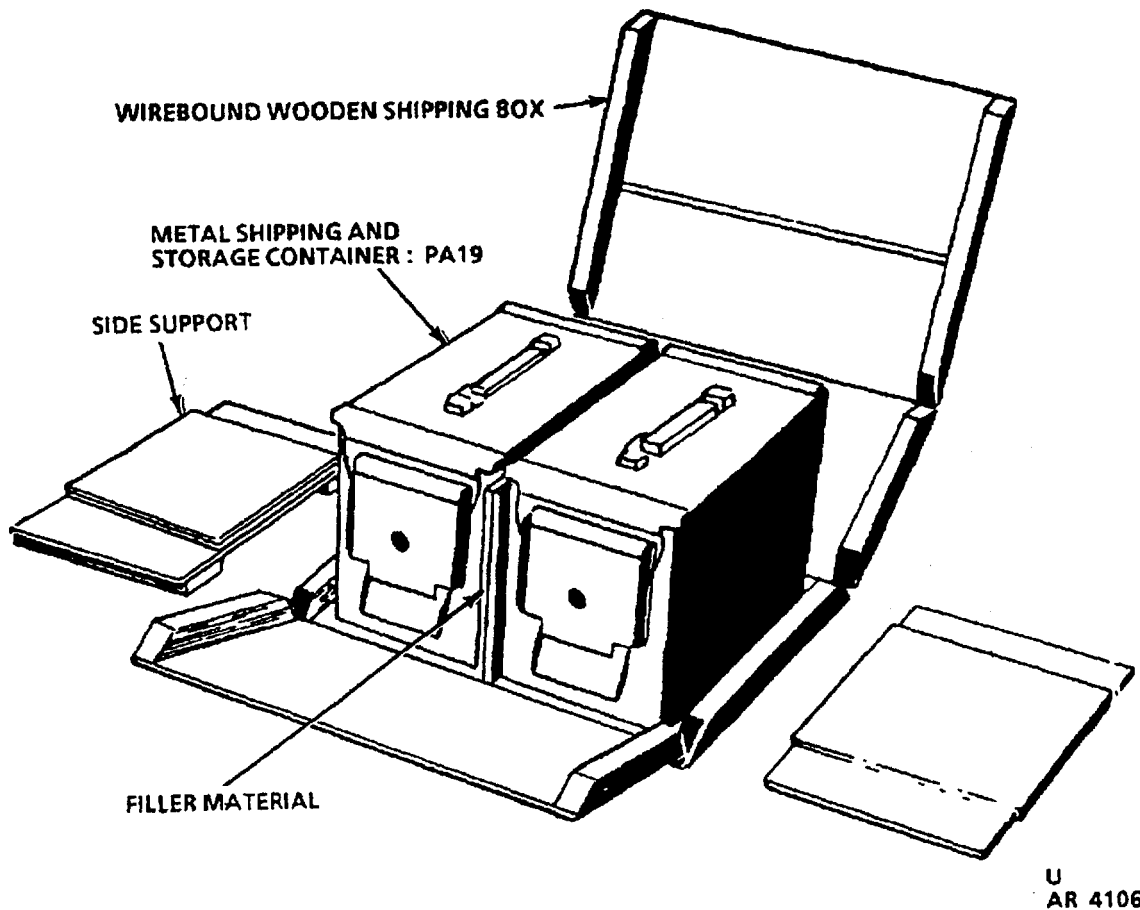

U  
AR 4106

Figure 2-13. Packing for mine, antipersonnel: M86.



**NOTE**

Once plastic bag has been opened, the M86 cannot be re-issued. Send mine to ammunition supply point (ASP).

- (4) Immediately prior to use, remove mines from inner plastic bag and inspect for defects (figs. 1-6, 1-7, and 2-14) listed in (4) (a) through (d) below. If such defects are found, report mine for disposition instructions.
  - (a) Missing, damaged or improperly assembled components:
    1. Safety pin
    2. Safety clip
    3. Arming strap ring
    4. Arming strap assembly
    5. Triplines (7 per mine)
    6. Bandoleer
    7. Nose protector loose or missing
  - (b) Missing, damaged, or incompletely sealed inner plastic bag
  - (c) Cracks in mine
  - (d) Improper marking on mine
- (5) Inspect mine for moisture, mildew, mold, or foreign material. If such are found, wipe with a clean cloth.

c. *Arming and Employing.*

**WARNING**

- **ONCE ARMING STRAP IS LIFTED, DEPLOYMENT IS MANDATORY. DO NOT ATTEMPT TO RESAFE.**
- **SAFE SEPARATION TIME IS 25 SECONDS AFTER STRAP IS LIFTED. LEAVE AREA IMMEDIATELY AFTER**

**EMPLOYMENT AND DO NOT RETURN TO AREA.**

- **THE M86 MINE HAS A SELFDESTRUCT FEATURE WHICH MAKES IT EXPENDABLE; THEREFORE, DO NOT RETURN TO AREA.**
- **DO NOT DEPLOY MINE BELOW -25F. IF MINE IS DEPLOYED BELOW -25°F, MINE MAY SELF-DESTRUCT EITHER IN A 5-MINUTE TIME FRAME, OR LATER THAN THE PROGRAMMED SELF-DESTRUCT TIMEFRAME.**
- **DO NOT REMOVE NOSE PROTECTOR OR NOSE PROTECTOR TAPE. REMOVAL OF TAPE MAY DAMAGE THE ELECTROMAGNETIC RADIATION (EMR) AND ELECTROSTATIC DISCHARGE (ESD) PROTECTIVE PAINTS.**
- **IF ONE OR MORE TRIPLINES ARE FOUND DEPLOYED PRIOR TO USE, DO NOT ARM OR ATTEMPT 'TO USE THE PDM. TURN IN MINE FOR DISPOSAL.**

**NOTE**

During a mission, if a mine is not to be employed immediately, replace mine in inner plastic bag and bandoleer until employment. At the completion of a mission, unused mines in unsealed bags will be sent to the ASP for disposal, in accordance with local SOP

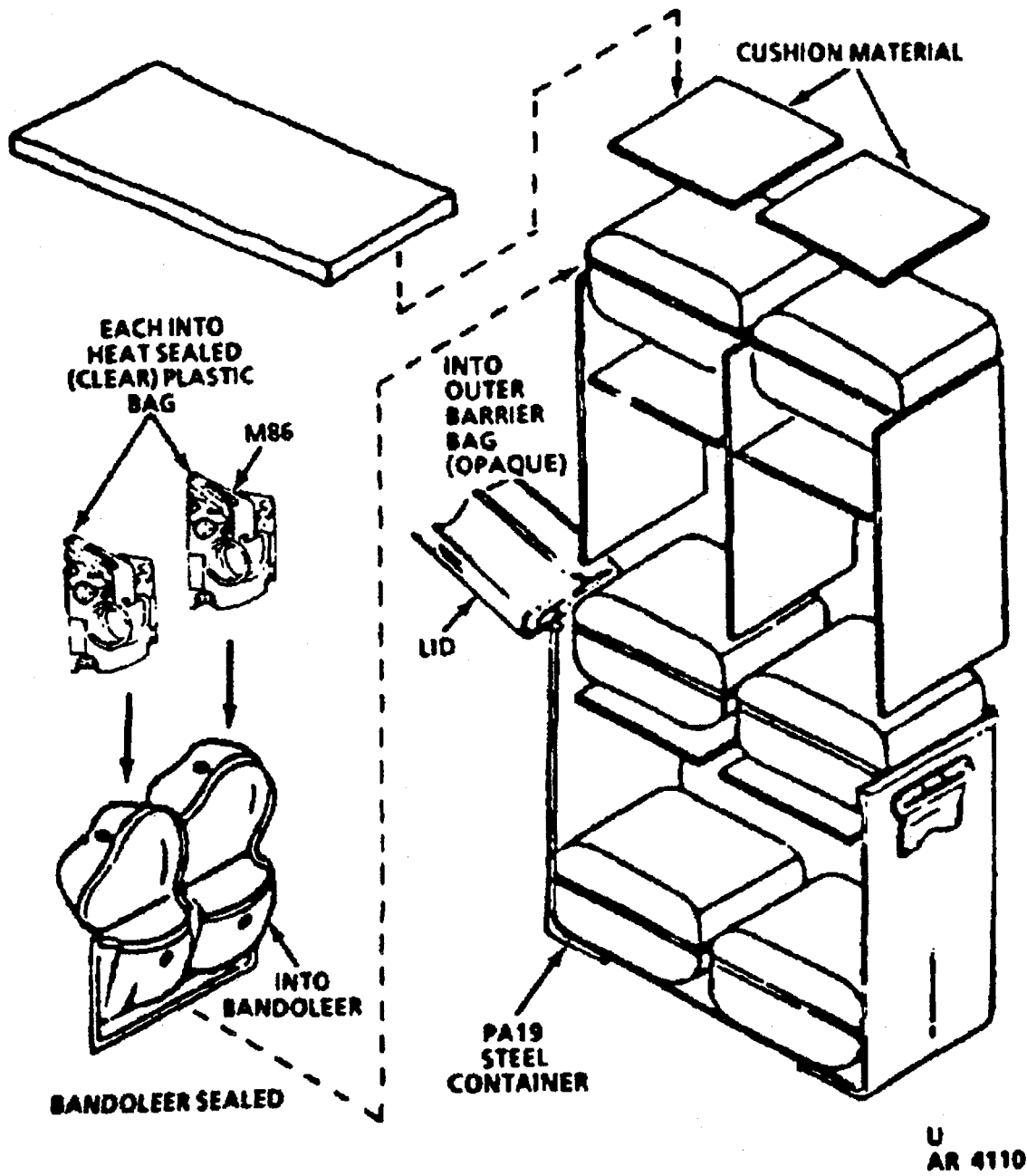

Figure 2-14. Packing (inner, intermediate, and outer) for mine, antipersonnel: M86.

2-15): The M86 mine is armed as follows (refer to fig.

- (1) Remove from bandoleer.
- (2) Remove mine from plastic bag.
- (3) Pull safety clip.
- (4) Pull arming strap ring.
- (5) Remove arming strap assembly completely.

**NOTE**

- Mine may not be armed without full removal of arming strap.
- **Employment.** Mine without support may roll down an embankment and function by antidisturbance device at the time of triplines deployment.
- (6) Deploy mines. All arming will occur automatically within the mine itself.

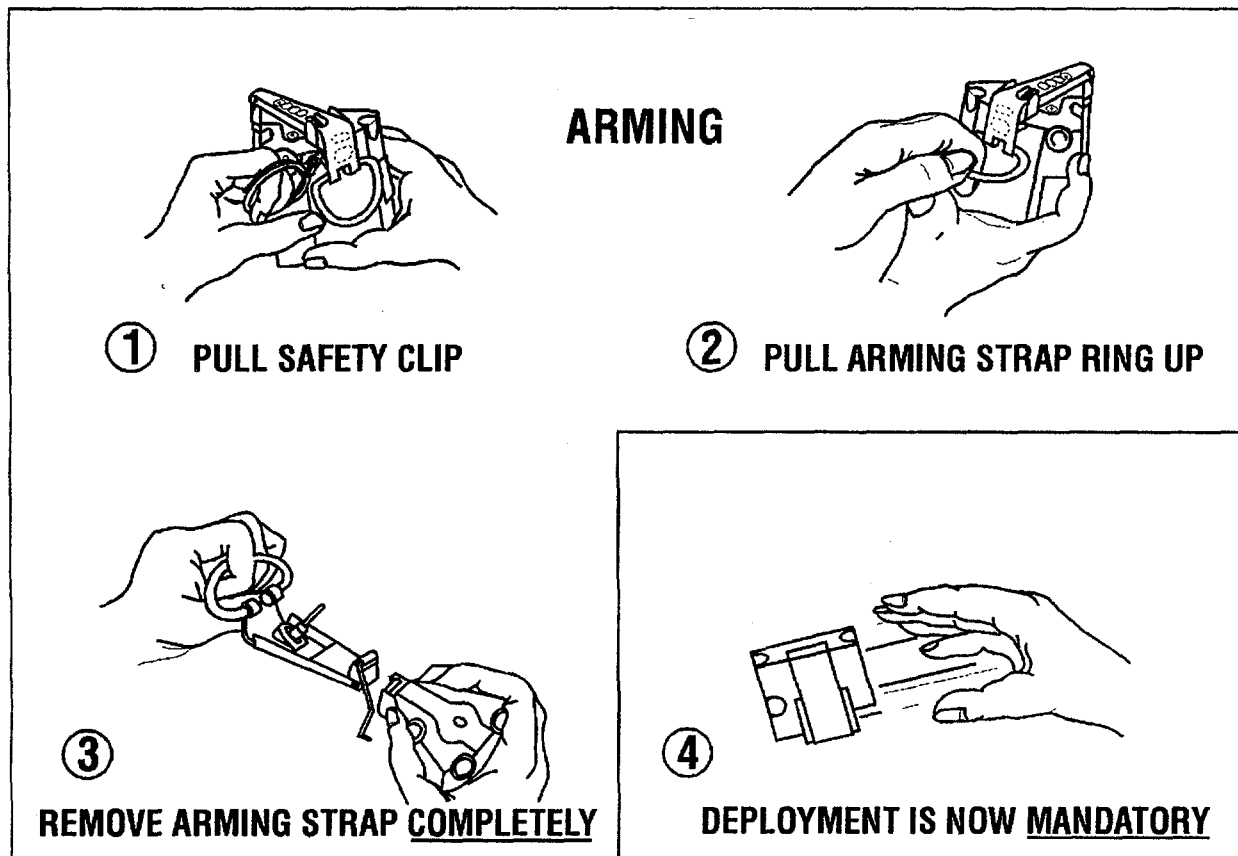

U  
AR 2691-A

Figure 2-15. Arming sequence, mine, antipersonnel: M86.

THIS PAGE INTENTIONALLY LEFT BLANK

**2-5. Mine, Antipersonnel, Practice: M8, With Fuze, Mine Combination, Practice: M10 or M10A1; Mine Antipersonnel, Practice: M8A1, and Fuze, Mine Combination, Practice: M10A2**  
(Figs. 2-16 and 2-17)

a. *Laying and Arming.*

**WARNING**

**MINE MS CONTAINS A CAE: PROJECTILE, AND SPOTTING CHARGE. WHEN THE MINE FUNCTIONS, THE CAP, PROJECTILE, AND SPOTTING CHARGE ARE PROPELLED UPWARD. MINE M8A1 HAS A PLUG WHICH IS PROPELLED UPWARD. PERSONNEL SHOULD BE AWAY FROM MINES AND UNDER COVER TO AVOID BEING STRUCK BY FALLING PARTS.**

**NOTE**

**The following procedures apply both to M8 and M8A1 mines, as applicable.**

- (1) Remove mine, firing mechanism, igniter assembly, spotting charge, and cardboard projectile from their packings (fig. 2-18).
- (2) Twist safety pins gently with fingers to check locking safety pin and positive safety pin for freedom from binding. If safety pins are not free enough to be removed easily, consider firing mechanism to be damaged. Replace with new unit.
- (3) Assemble firing mechanism to igniter assembly. Inspect fuze well of mine; remove foreign material, if present.
- (4) Grasp knurled edge of base coupling, and screw fuze into well of mine.
- (5) Fit spotting charge into cardboard projectile (canister). (Mine M8A1: Place smoke pellets in mine body.)
- (6) Insert cardboard projectile (with spotting charge) into projectile tube. Snap mine cap (cover) over projectile. (Mine M8A1: Place plug in mine body.)

- (7) Lay mine in hole (about 10 inches deep and 5 inches in diameter) on firm foundation, with tips of fuze prongs extending just above ground level.
- (8) Pack dirt around mine cap to assure mine is firmly emplaced.
- (9) Attach one or more tripwires to firmly-driven anchor stakes, then to release-pin ring. Leave enough slack to allow top of fuze to rotate and receive direct pull on release pin ring from any one of tripwires.
- (10) Remove locking safety pin by pulling on cord to which it is attached.
- (11) Camouflage installation in accordance with instructions in FM 2032. Do not disturb tripwires.
- (12) Remove positive safety pin by pulling on cord to which it is attached, thus arming fuze.
- (13) Save safety pin for subsequent disarming of fuze.

b. *Disarming and Removal (Neutralizing) (Mine M8).*

- (1) Carefully inspect installation for booby trapping devices, then remove camouflage material.
- (2) Insert positive safety pin first, then insert locking pin. Disconnect tripwires. Remove mine from hole.
- (3) Remove fuze. Unscrew firing mechanism from igniter assembly.
- (4) Remove mine cap and spotting charge from cardboard projectile.
- (5) Restore mine, firing mechanism, igniter assembly, spotting charge, cardboard projectile, and mine cap to their original condition and packing (fig. 2-16).

**NOTE**

**The above procedure is applicable to the mine M8A1 with the exception of steps (4) and (5). Prior to repacking mine M8A1 (as step (4)) remove smoke pellets, place in safe location, and repackage mine in original packing (fig. 2-17).**

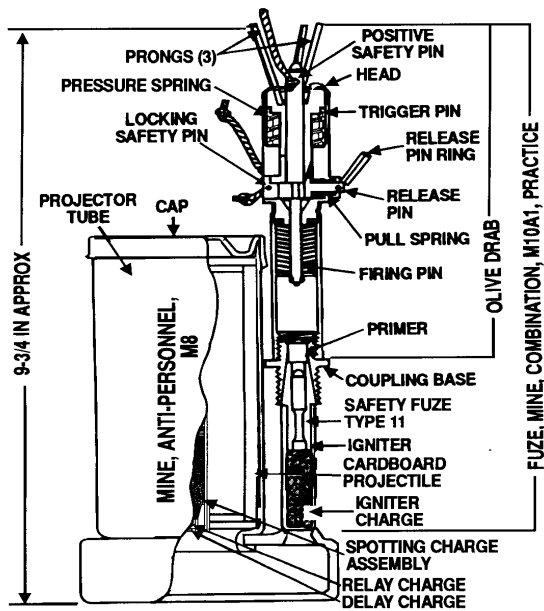

U  
AR 100348

Figure 2-16. Mine, antipersonnel, practice: M8, with fuze, mine combination, practice: M10 or M10A1.

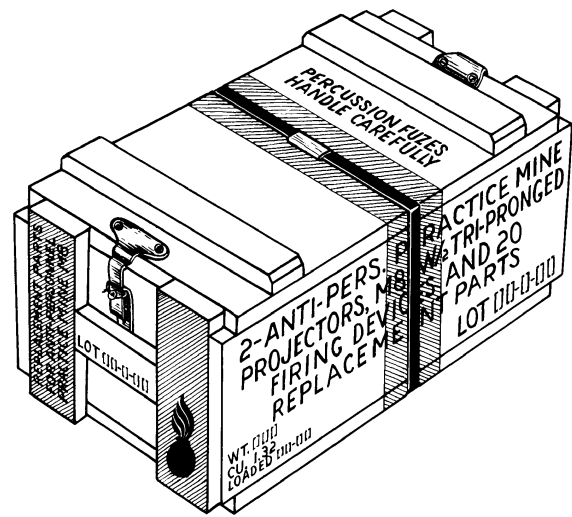

AR 101121-A

Figure 2-18. Packing box for two antipersonnel practice mines M8 and twenty of each replacement part.

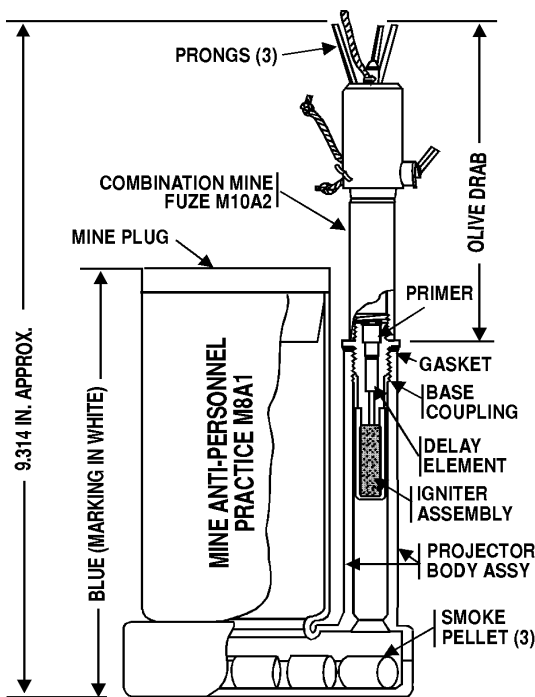

U  
AR 100121-A

Figure 2-17. Mine, antipersonnel, practice: M8A1, with fuze, mine combination: practice, M10A2.

## 2-6. Mine, Antipersonnel, Practice: M68 (Figs. 1-9 and 2-8)

a. *Laying and Aiming.* Perform procedures in accordance with paragraphs 2-3b and c, which cover the mine M18A1.

b. *Arming, Testing, and Electrical Firing.* Perform procedures in accordance with paragraph 2-3d, which covers the mine M18A1.

### **WARNING**

**USE PRACTICE BLASTING CAP M10 ONLY WITH MINE M68. DO NOT USE M6, M7, OR ANY OTHER LIVE CAP WITH IT. NO SUBSTITUTIONS ARE ALLOWED.**

c. *Disarming and Destruction.* Perform procedures in accordance with paragraph 2-3g, except components need not be destroyed. (These procedures cover the mine M18A1).

**2-7. Mine, Antitank: HE, Heavy, M15, with Fuze, Mine, AT, M603 and Activator, AT, Mine: M1 or with Fuze, Mine: M624 (Figs. 1-10 and 1-11).**

a. *Casualty Effect and Danger Area.*

- (1) Mine is intended for use against heavy tanks and other heavy tracked and wheeled vehicles.
- (2) Mine will disable tank by breaking tracks and road wheels or other parts of the suspension system.
- (3) Blast effect of the HE contained in the mine can be lethal and cause casualties.

b. *Sympathetic Detonation.*

- (1) When buried 1 to 2 inches underground, sympathetic detonation will not occur when mines are at least 5 feet apart.
- (2) When fuze is flush with ground, sympathetic detonation will not occur when mines are at least 8 feet apart.
- (3) When laid on top of ground, sympathetic detonation will not occur when mines are at least 14 feet apart.

c. *Laying and Arming with Fuze, Mine M603.*

**WARNING**

**DO NOT CARRY THIS MINE BY THE HANDLE. THE HANDLE MAY OPEN UP AND THE MINE WILL FALL OFF.**

- (1) Remove mine from packing box (fig. 2-19) and examine mine for dents, cracks, or other damage. If mine is damaged, set it aside and remove another mine.

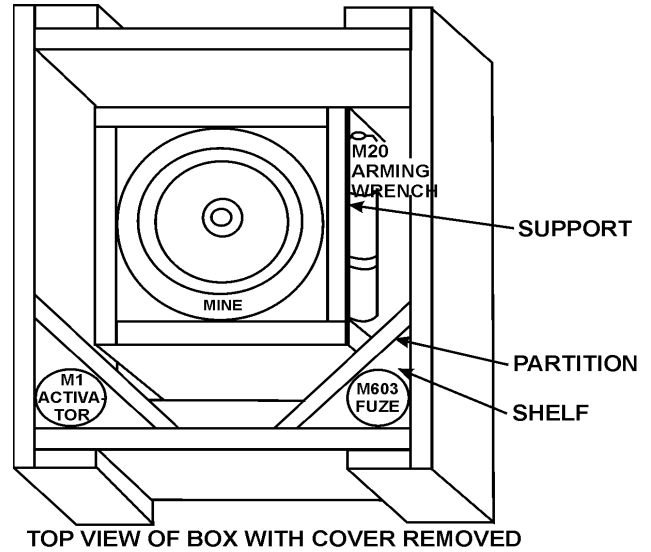

Figure 2-19. Packing box for mine M15 and M624, fuze M603, and activator M1.

- (2) Using arming wrench M20 (fig. 2-20), unscrew arming plug by turning plug counterclockwise; remove plug from mine.

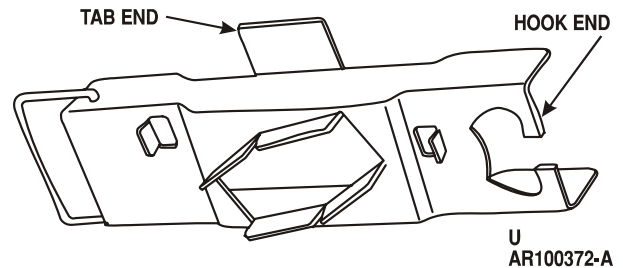
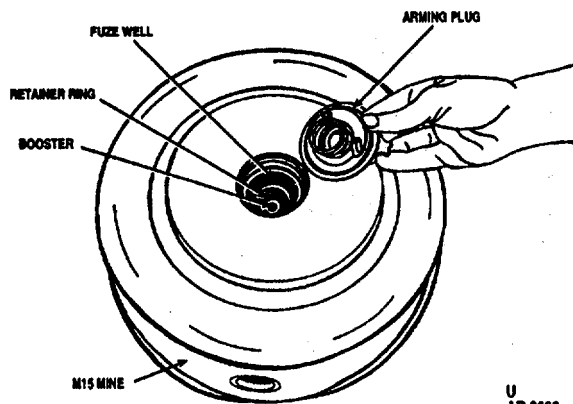

Figure 2-20. Arming wrench M20.

- (3) Examine fuze well for foreign matter. If present, remove. Water in fuze well can result in duds in areas where temperature falls below freezing (fig. 2-21).
- (4) Assure booster retainer is seated in fuze well. If retainer is missing, replace mine (fig. 2-21).



U  
AR 2666

Figure 2-21. Fuze well.

- (5) Set mine down, pick up fuze metal container M603 (fig. 2-22).

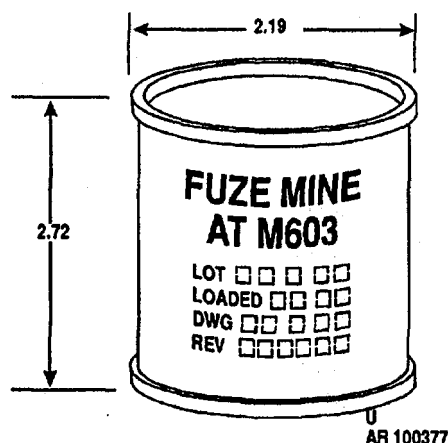

U  
AR 100377

Figure 2-22. Fuze M603 metal container.

- (6) Open container with keyway attached to bottom of can.
- (7) Remove fuze (fig. 2-23). Assure safety clip is in place between pressure plate and body of fuze. Turn fuze over and assure that varnished or painted lining compound, on end of detonator, shows in bottom of fuze.

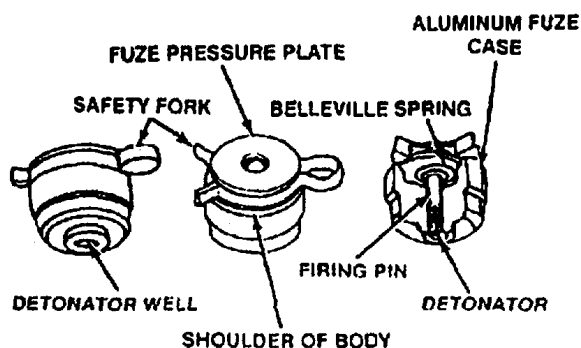

AR 100376

Figure 2-23. Fuze, mine, AT, M603.

- (8) For long term emplacement, coat fuze with silicone grease G-697 (fig. 2-24) and smear layer of grease on threads and walls of fuze well of mine.

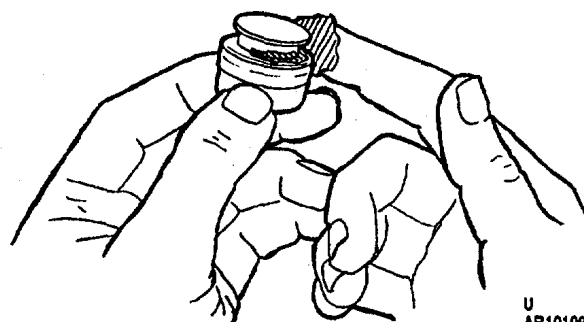

U  
AR 101087

Figure 2-24. Coating fuze M603 with silicone grease G-697.

- (9) Remove safety clip from between pressure plate and body of fuze. (Can be done with hook end of wrench M20.) Retain safety clip for future use, if required to disarm mine.
- (10) Insert fuze into fuze well. Assure fuze is seated securely on top of booster retainer. Put no pressure on pressure plate when handling fuze.



- (11) Check clearance of pressure plate of fuze in fuze well by using tab end of wrench M20 (fig. 2-20). If pressure plate is too high, the bottom of the plate will interfere with the movement of the arming shutter in arming the mine. If fuze does not fully seat, remove and replace with another fuze.
- (12) Pick up arming plug M4 and turn setting knob to SAFE position (if not already set to SAFE position) (fig. 2-25).

- (13) For long-term emplacement, smear layer of silicone grease G-697 on threads, gasket, and shutter on underside of the arming plug.
- (14) Screw arming plug clockwise into fuze well of mine (fig. 2-26).
- (15) Tighten arming plug with wrench M20 to assure watertight joint.
- (16) For long-term emplacement:
  - (a) Coat outside of arming plug 360° with grease G-697.
  - (b) Smear film of grease 360° on joint where mine pressure plate is attached to mine body.
- (17) Dig hole approximately 15 inches in diameter and 6 inches deep, with walls sloping 45° to avoid bridging (fig. 2-26).
- (18) Check bottom of hole to assure ground is solid and mine will not sink in ground. If not solid, insert wood board or other surface to give mine firm foundation.
- (19) Lay mine in hole so that top surface of pressure plate is approximately 1 1/2 inches below the surface of the ground (fig. 2-27).

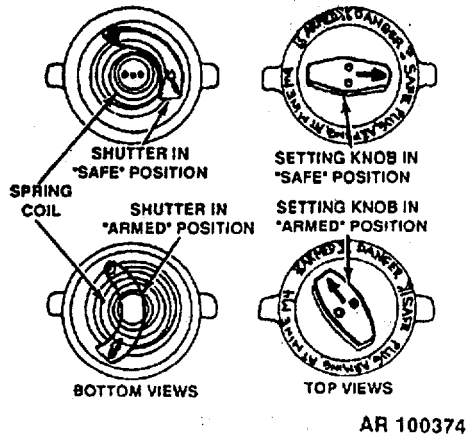

Figure 2-25. Setting knob in SAFE and ARMED positions.

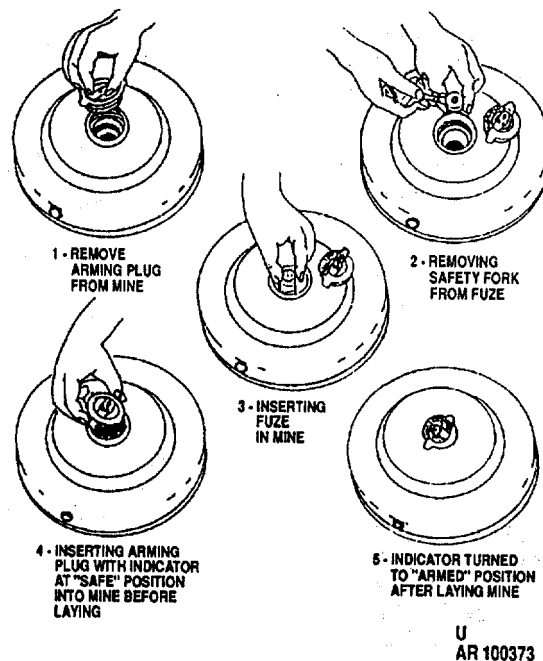
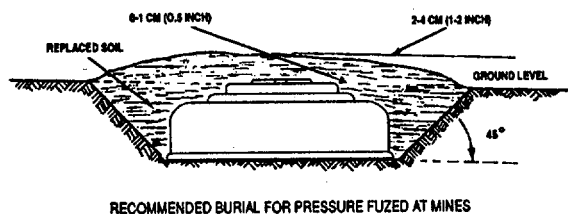

Figure 2-26. Inserting M603 fuze and arming mine M15.



U  
AR 101088-B

Figure 2-27. Emplacing mine M15.

(20) Fill in dirt around mine and pat down.

**NOTE**

Because of tolerances permitted in manufacture, the pressure plate of fuze M603 may extend too high, making it difficult, if not impossible, to turn knob on arming plug to ARMED position. Do not attempt to force knob but, if necessary, unscrew arming plug just enough to allow knob to be turned freely. Never point setting knob to (21) Using wrench M20, arm mine by turning setting knob with pointer from SAFE through DANGER to ARMED.

(22) Camouflage mine installation in accordance with instructions in FM 20-32.

(23) A pressure of 350-750 pounds on pressure plate will function the mine.

d. *Laying and Aiming Fuze, Mine: M624.*

**WARNING**

THE M624 FUZE CANNOT BE DEPLOYED BY THE M57 ANTITANK MINE DISPENSER OR BY ANY OTHER MECHANICAL MEANS. THE DISPENSER WILL INITIATE THE M624 FUZE.

- (1) Remove mine and arming wrench from packing box (fig. 2-19).
- (2) Inspect mine for serviceability. Check for cracks, dents, or other signs of damage. If damaged, replace with new mine. Mark and return damaged mine to supply.
- (3) Using arming wrench M20 if necessary (fig. 2-20), unscrew arming plug by turning plug counterclockwise; remove plug from mine (fig. 2-21).
- (4) Examine fuze well for foreign matter. If present, remove. Water or dirt in fuze well can result in duds.
- (5) Assure booster retainer is seated in fuze well. If retainer is missing, replace mine (fig. 2-21). Mark and return damaged mine to supply.

**NOTE**

Keep M624 Fuze in ammunition box until fuze is to be emplaced.

- (6) For buried application, temporarily cover fuze well with arming plug to keep it free of foreign matter. Prepare a hole in ground 15 inches in diameter and 6 inches deep.
- (7) Check bottom of hole to assure ground is solid and provides firm, flat foundation for mine to rest on. If ground is soft, mine may tilt and lose effectiveness. In soft ground, place board or flat object under mine to provide firm foundation.
- (8) Place mine in hole (fig. 2-28).

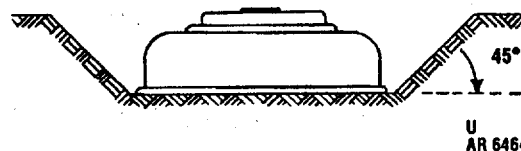
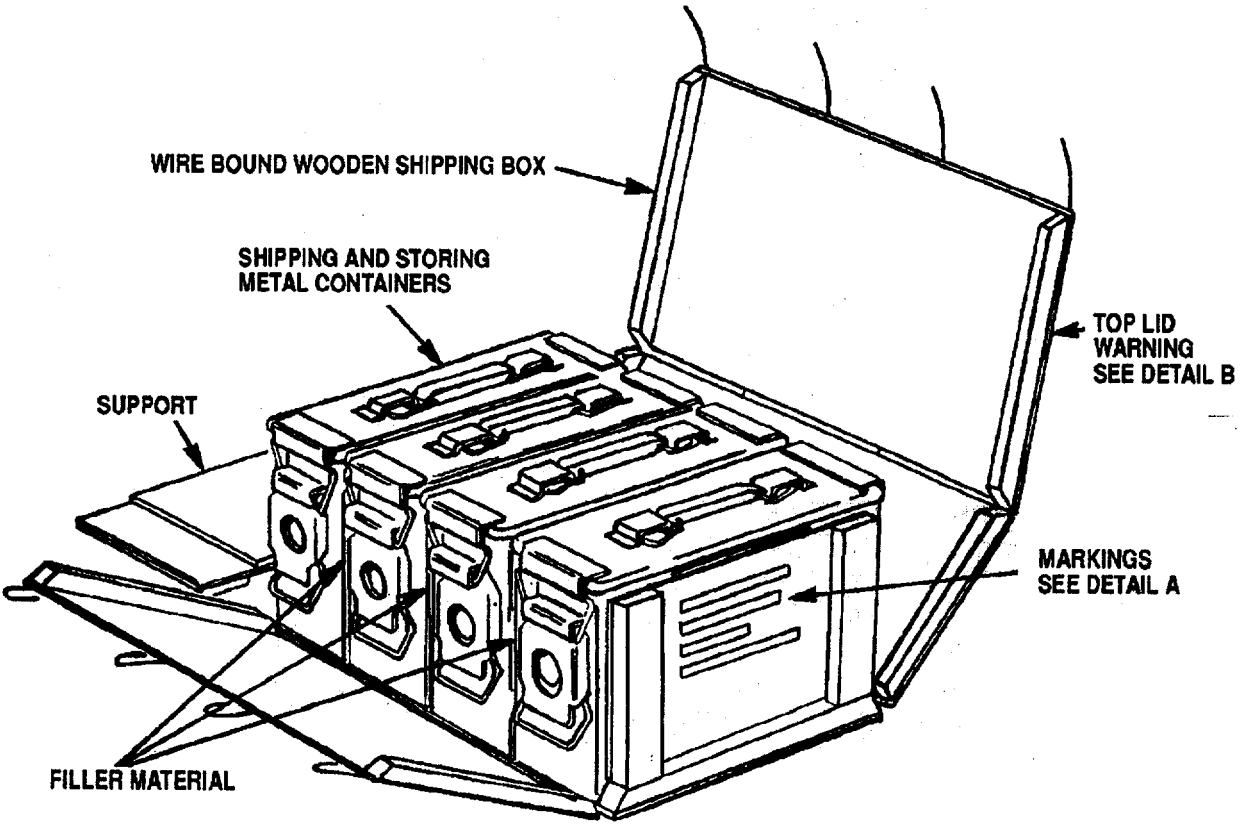
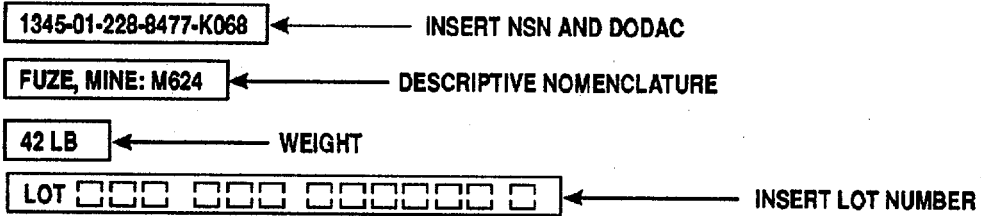

Figure 2-28. Laying mine into pit.

(9) Open packing box and metal container for the M624 fuze (figs. 2-29 and 2-30).



MARKINGS DETAIL A



WARNING DETAIL B



U  
AR 6465

Figure 2-29. Outer packing for M624 fuze.

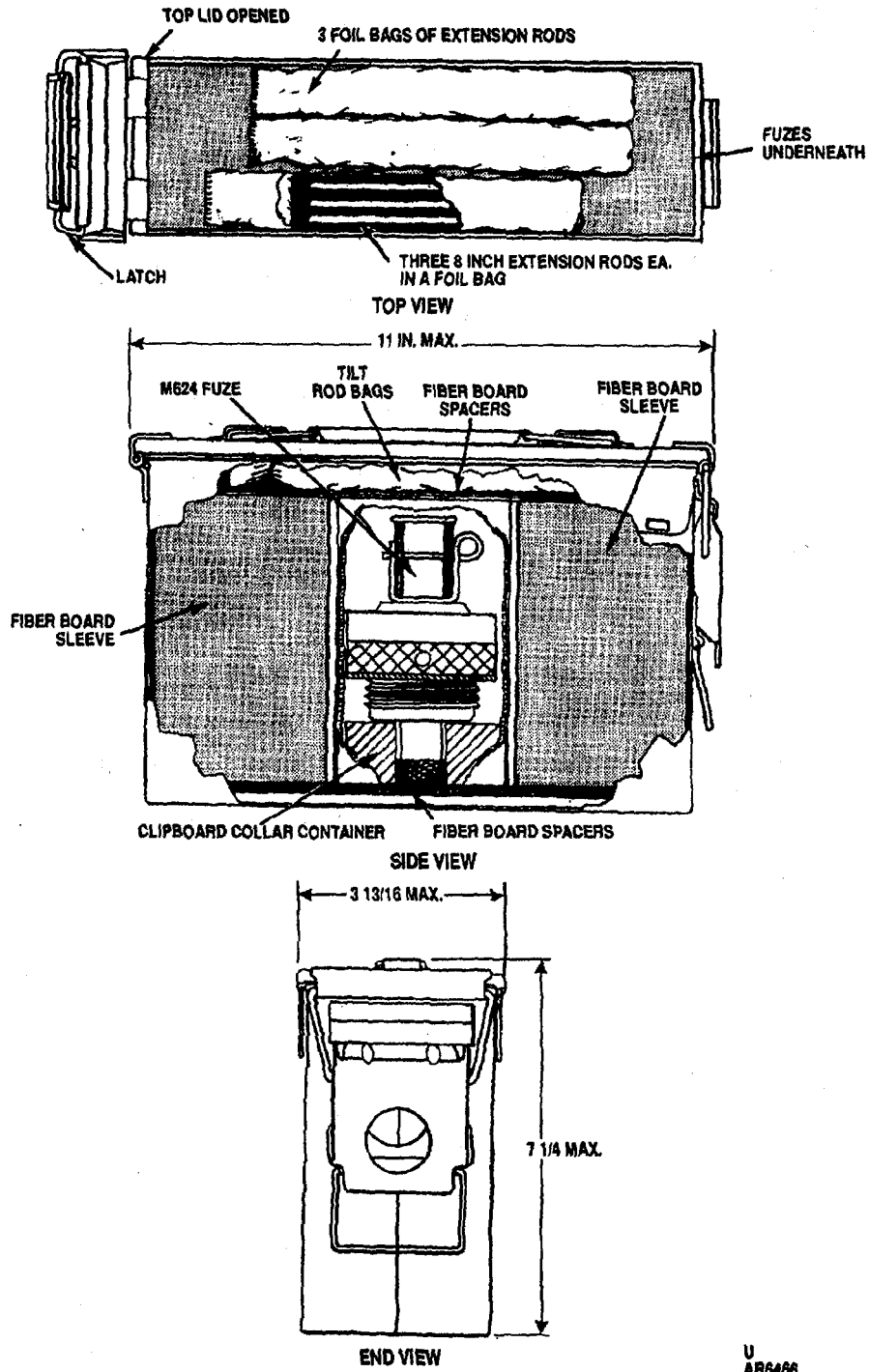

U  
AR6466

Figure 2-30. Inner packing for M624 Fuze.

THIS PAGE INTENTIONALLY LEFT BLANK

**NOTE**

A modified safety pin has been produced which has a bend (hook) at the end of the pin. Either the original or modified pin may be used. However, when using the modified (hook) type, it must be unhooked before resafing, and rehooked after being placed in the proper resafing position. Otherwise the functions are the same.

rods (fig. 2-30). Prior to removing fuzes from metal container, visually inspect all three fuzes for proper assembly of safety pin (figs. 2-31, 2-32, and 2-33). Inspect plastic collar of each fuze by looking down through top of pressure ring. If safety pin is missing or improperly assembled, or if plastic collar appears cracked, leave deficient fuze(s) in container and remove good fuzes. Turn in defective fuze(s) in container to ammunition supply point for disposal.

(10) Remove the three packages of extension

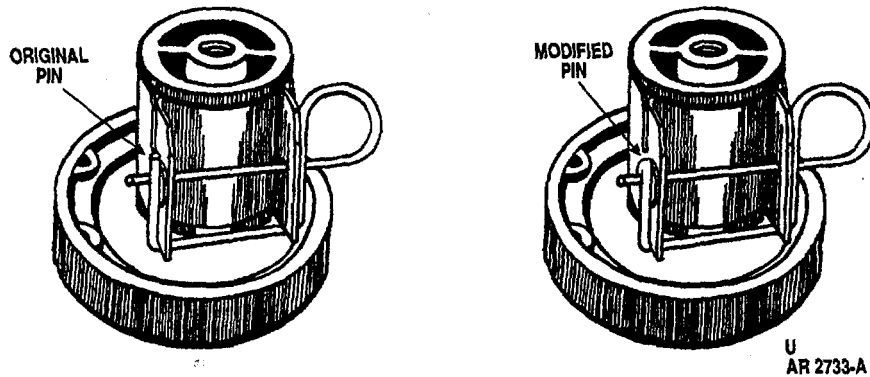

Figure 2-31. Correct configuration of M624 fuze.

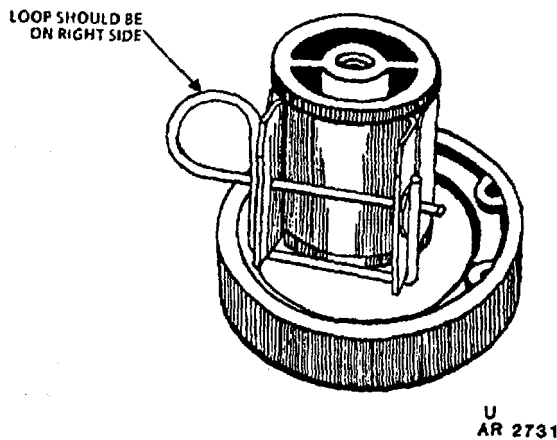

Figure 2-32. Wrong. Safety pin loop should be on right side.

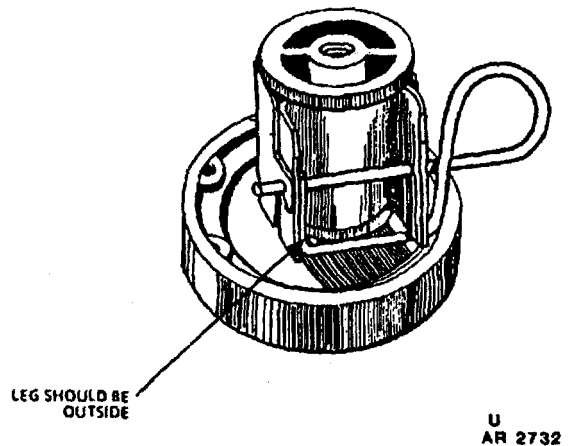

Figure 2-33. Wrong. Safety pin left leg should not be assembled inside safety band.

- (11) If safety pin is assembled properly and collar is not cracked, remove one fuze from its fiber sleeve along with one package of extension rods (fig. 2-30).
- (12) Coat fuze threads and gasket with silicone grease G-697 or equivalent prior to removing end closure (fig. 2-34). Obtain grease from supply (Appendix D).

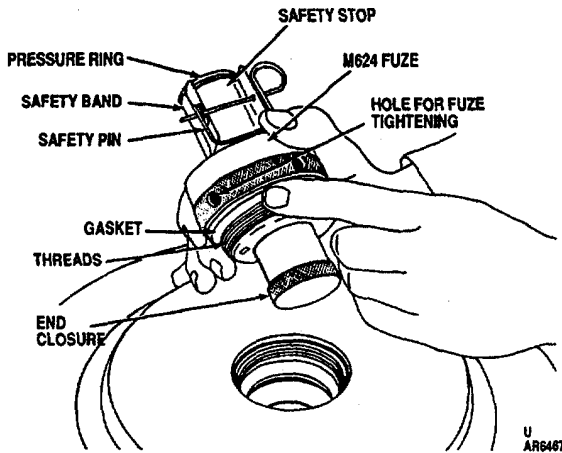

Figure 2-34. Safety pin and M624 fuze greasing.

- (14) Screw fuze clockwise hand-tight into threaded fuze well of mine (fig. 2-36). Remove extension rod from packaging. To tighten fuze, insert one unthreaded end of extension rod piece in the hole on the side of the adaptor and turn the fuze a quarter turn. After fuze is secure, remove extension rod for further use (fig. 2-37).

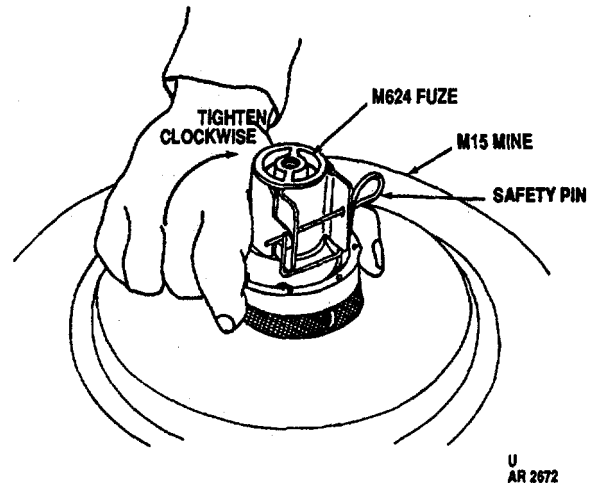

Figure 2-36. Tighten fuze by hand.

- (13) Unscrew and remove end closure on the M624 fuze (fig. 2-35).

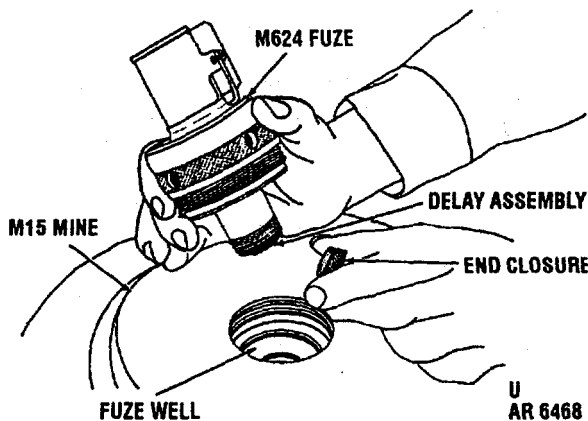

Figure 2-35. Unscrew and remove end closure.

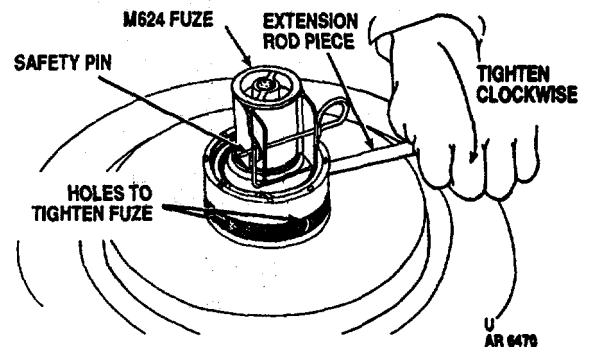

Figure 2-37. Tighten fuze with extension rod.

- (15) For buried mines, press ground firmly against side of mine, leaving top of fuze uncovered (fig. 2-38).

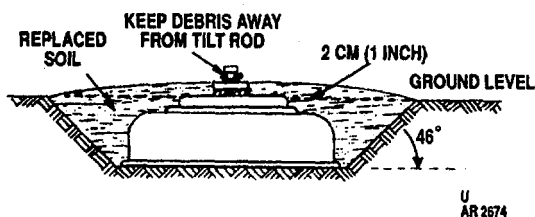

Figure 2-38. Recommended burial for tilt rod fuze AT mines.

**NOTE**

The most effective operation is with the extension rod installed, and this method is recommended. However, mine may be set up for pressure operation; proceed to paragraph (18) below. For extension rod operation, continue with paragraphs (16) and (17).

- (16) For buried application, assemble all three pieces of extension rod together (fig. 2-39). Then, thread extension rod into threaded pressure ring of fuze (fig. 2-40). For surface emplacement, use first two sections of extension rod only.

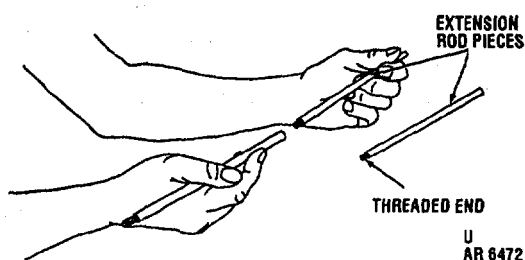

Figure 2-39. Extension rod assembly.

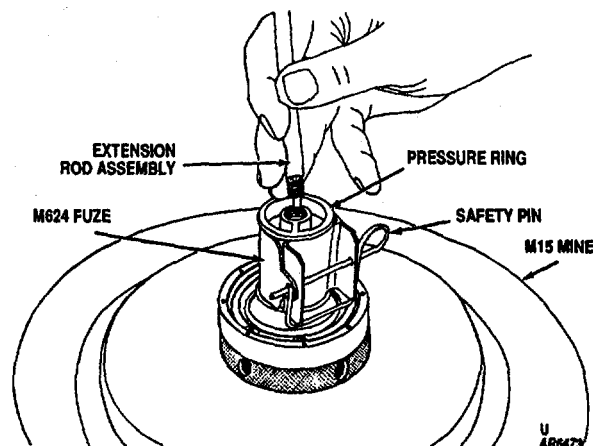

Figure 2-40. Assembly of extension rod into fuze ring.

- (17) Assure that extension rod is vertical and not tilted in any direction.

**NOTE**

If extension rod operation is not used, set up for pressure operation.

- (18) For pressure operation, do not use extension rod assembly. A vertical force of 290 pounds on pressure ring will function fuze. After extension rod operation or pressure operation, the mine is ready for arming.

**WARNING**

WHEN REMOVING SAFETY PIN, CAREFULLY PULL AND SLIDE OUT CAREFULLY LAYING IN THE PRONE POSITION. ONCE ARMED, DO NOT TOUCH OR APPLY PRESSURE TO THE EXTENSION ROD A MINIMUM HORIZONTAL FORCE OF 3.75 POUNDS (SMALL FORCE) AT THE END OF EXTENSION ROD, OR A MINIMUM HORIZONTAL FORCE OF 45 POUNDS ON THE SIDE OF THE PRESSURE RING WILL INITIATE FUZE. CAREFULLY FOLLOW INSTRUCTIONS AND FIGURES BELOW.

**NOTE**

When the modified (hook) type safety pin is used, unhook prior to arming, and rehook after resafing.



- (19) To arm fuze, lie in prone position, raise safety pin to horizontal position, and grasp safety bank and safety stop with left hand (fig. 2-41) (note position of thumb). With right hand index finger, pull safety pin out while sliding it to the right (figs. 2-42 and 2-43). Carefully remove safety stop while holding safety band in place. If any cracks are noted in plastic collar, while still in prone position, slowly and carefully reassemble stop and safety pin on fuze so that pressure ring is immobilized. Remove extension rod carefully. Remove fuze from mine, using extension rod if necessary. Turn fuze in to ASP for disposal and replace it with a new fuze. If no cracks are noted, carefully remove the safety band (fig. 2-44). THE FUZE IS NOW ARMED!

be restored. If the M15 mine has been destroyed, packaging and all inside components may be destroyed.

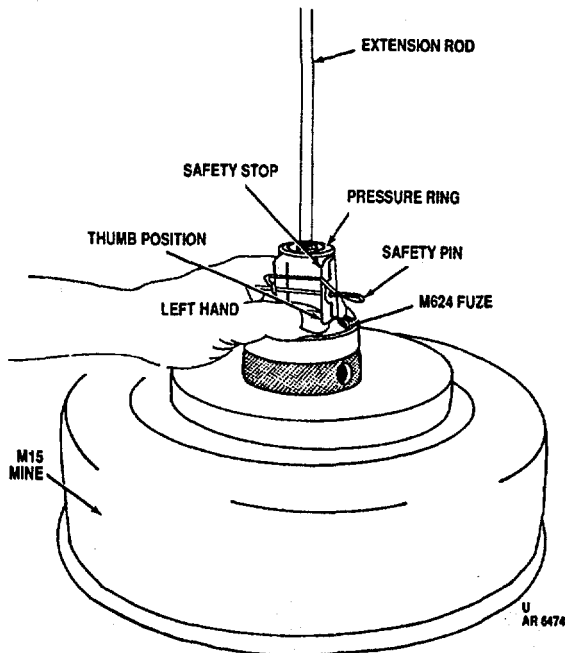

Figure 2-41. Left hand grasping fuze (arming fuze).

- (20) After emplacement of M15 mine with M624 fuze, all unused M603 fuzes, end closures, safety pins, bands, stops, arming plugs, and arming wrenches must be retained and stored in their respective packaging material and then turned into supply. They will remain in storage until the M15 mine has been destroyed or is to

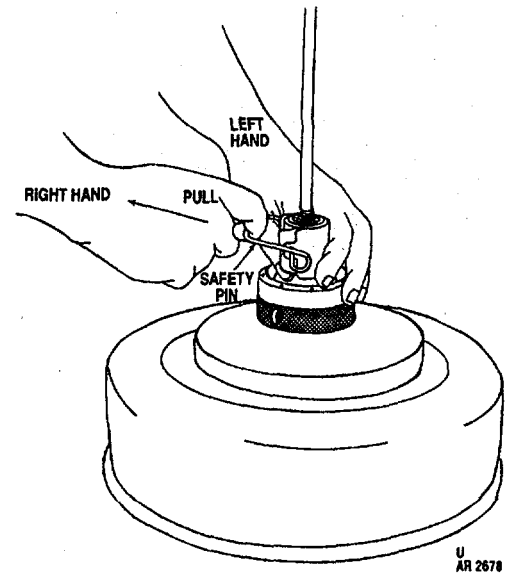

Figure 2-42. Pull with right hand (arming fuze).

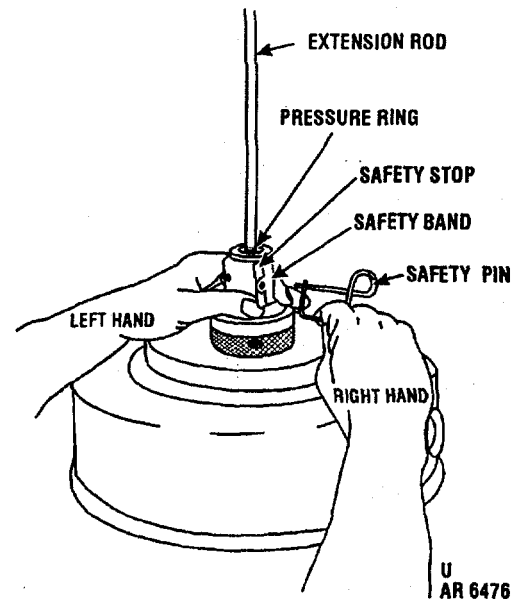
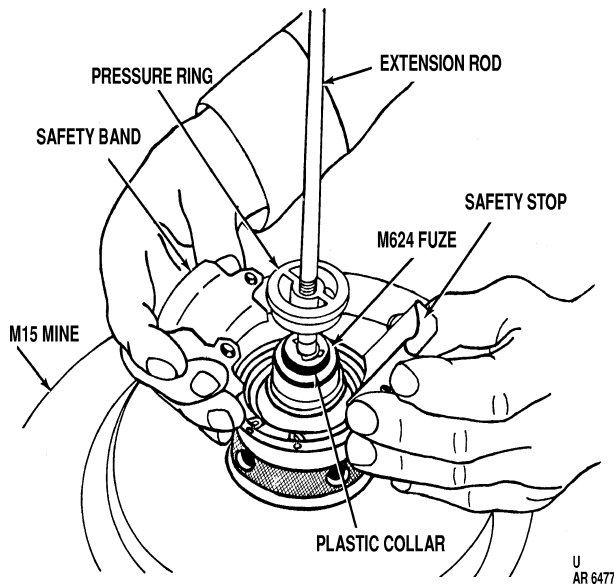

Figure 2-43. Removal of safety pin (arming fuze).



**Figure 2-44. Remove safety band and stop (fuze is armed).**

(21) Camouflage installation in accordance with instructions in FM 20-32, being careful not to move extension rod or place any material in a position that will prevent movement of extension rod or pressure ring.

e. *Boobytrapping* (figs. 2-45 and 2-46).

**NOTE**

As mine employs activator M1, which is a high-explosive booster, and is equipped with two secondary fuze wells, the wells may be used for boobytrapping. Any firing device with standard base coupling or firing devices with 0.5625 outside thread can be used with activator M1 for this purpose (fig. 2-45).

(1) Remove tape and shipping sleeve from secondary fuze well (side, bottom, or both).

(2) Check secondary fuze wells for foreign matter, or corrosion. Remove foreign matter, if present. If either secondary fuze well has corrosion, the mine will not be used. Assume that loose explosive exudate is present and treat accordingly.

(3) Remove activator from metal container and examine for cracks, dents, or other damage. If damaged, do not use; replace with new activator.

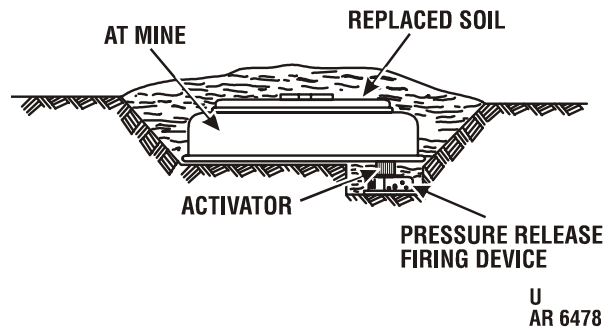

**Figure 2-45. Antihandling devices.**

(4) Remove closing plug and gasket from activator and save for reuse if needed for disarming.

(5) Screw activator into secondary fuze well of mine. Assure that small rubber gasket is in place inside activator.

(6) Screw applicable firing device, which has standard base coupling of 0.5625 outside thread, into activator hand tight.

(7) For tripwire activation, set up anchor posts as needed and install required tripwires.

(8) For additional information on firing devices and methods of installing and using, refer to FM 5-250 or TM 9-1375-213-12.

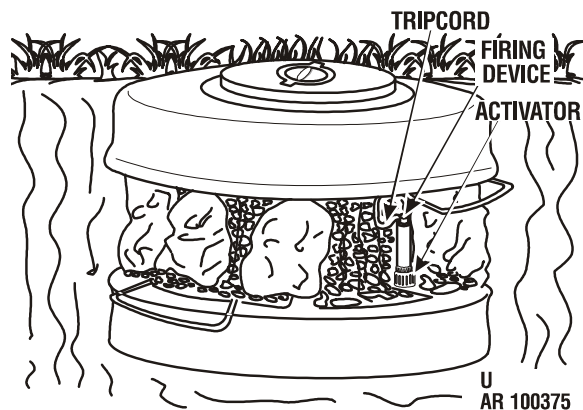

**Figure 2-46. One method of boobytrapping mine M15.**

f. *Disarming and Removal of M15 Mine with M603 Fuze.* In cases where mine must be neutralized, disarmed, and removed, the following procedure shall be followed:

(1) Carefully check area for presence of tripwires or other boobytrap devices. DO NOT CUT TAUT TRIPWIRES. Do not cut all slack wires.

**WARNING**

**IF TAUT WIRES ARE ENCOUNTERED WHEN ATTEMPTING TO NEUTRALIZE MINE, DO NOT CUT WIRES UNDER ANY CIRCUMSTANCES. ATTACH LONG ROPE OR WIRE TO MINE WITHOUT DISTURBING TAUT TRIPWIRE; THEN, FROM AN UNMINED PROTECTED POSITION, REMOVE MINE CAUTIOUSLY – MINE MAY DETONATE – BY PULLING ROPE OR WIRE. IF THIS METHOD IS NOT PRACTICABLE, REFER MATTER TO SPECIALLY TRAINED PERSONNEL.**

**DO NOT MISTAKE CHEMICAL MINE FOR A MINE M15. THE MINE M23 IS SIMILAR IN SIZE AND SHAPE TO THE MINE M15. THE CHEMICAL MINE CAN BE DISTINGUISHED VISUALLY AND BY TOUCH FROM THE MINE M15, BY EIGHT RAISED PROJECTIONS SPACED IN PAIRS AROUND THE PERIPHERY OF THE TOP OF THE CHEMICAL MINE.**

(2) When area is clear, approach mine and carefully remove dirt or other camouflage material on mine.

(3) Carefully remove dirt from sides of mine, assuring no boobytrap has been set up as an antihandling device. If in doubt, proceed as in warning above.

(4) If firing devices have been used with activator M1, replace all safety pins in firing devices, always replacing positive safety pin first. Then, remove any tripwire from firing device.

(5) Unscrew activator.

(6) Replace plug and gasket in head of activator. Set activator aside in secure place.

(7) Using wrench M20, slowly turn setting knob from ARMED through DANGER to SAFE. Do not force. If difficult to turn, indication is that pressure plate of fuze is in way of arming shutter and forcing may lead to detonation of the mine. Detonate in place in accordance with established procedures.

(8) If arming knob turns without forcing, leave on SAFE.

(9) Using wrench M20, turn arming plug M4 counterclockwise to loosen.

(10) Remove arming plug from mine.

(11) Remove fuze M603 from fuze well, grasping fuze pressure plate. Assure no pressure is put on pressure plate. Fuze should come out easily. Handle carefully; it contains detonator. If difficult, leave alone.

(12) Insert safety fork under pressure plate and place fuze in secure container.

(13) Insert arming plug M4 into fuze well.

(14) Replace mine in packing box in original packing, if possible.

(15) Replace tape over secondary fuze well.

g. *Disarming and Removal of M15 Mine with M624 Fuze.*

- (1) Check area for boobytraps. If present, notify EOD personnel.
- (2) If area is clear, approach mine and examine carefully. If extension rod appears tilted or plastic collar is broken, do not attempt to disarm, but call disposal officer.
- (3) Remove camouflage material, being careful not to move extension rod or pressure ring on fuze.
- (4) Slowly and carefully reassemble band, stop, and safety pin assembly on fuze so that pressure ring is immobilized.
- (5) Remove extension rod and be careful not to damage it.
- (6) Carefully dig around mine (if buried) so that mine may be removed. If mine has been emplaced with an antihandling device, do not proceed. Using long rope, tie onto mine fuze. Move to secure location and pull mine from hole. If antihandling device has been used, mine will explode.
- (7) Remove mine from hole in ground.
- (8) Remove fuze from mine, use extension rod.
- (9) Install shipping plug assembly into fuze hole of mine.
- (10) Repackage fuze and extension rods in original container (figs. 2-29 and 2-30).
- (11) Repackage mine and components into original container (fig. 2-19).

h. *Emplacement Life.* Emplacement life of mine M15 in various environments, without above long-term preparation, calculated to 70 percent effectivity, follows: (With above long-term preparation it is estimated emplacement life is increased approximately two to three times.)

Environment	Emplacement life (months)
Temperature zone --- clay soil	16
Temperature zone --- sandy soil	16
Tropic zone --- with heavy rainfall	6

**2-8. Mine, Antitank: HE, Nonmetallic (NM): M19, with Fuze, Mine, M606 (Fig. 1-12)**

a. *Casualty Effect and Danger Area.*

- (1) Antitank mine is intended for use against heavy tanks and heavy tracked and wheeled vehicles.
- (2) Because it is made of nearly all plastic material, the mine is non-detectable by magnetic mine detectors.
- (3) When buried 1-1/2 inches deep, the mine will completely immobilize light and heavy tanks by damaging the tracks and wheels of vehicles.
- (4) Casualties and injuries to personnel may result from the blast effect of the detonation of the main charge of the mine.

b. *Sympathetic Detonation.*

- (1) When buried 1-1/2 inches deep, sympathetic detonation will not occur when mines are at least 18 feet apart.
- (2) When buried 2 inches deep, sympathetic detonation will not occur when mines are at least 15 feet apart.
- (3) When laid on top of ground, sympathetic detonation will not occur when mines are at least 25 feet apart.

**NOTE**

**Mine, antitank, training: M80 is the exact duplicate of mine M19 but contains no explosive components. It is used for training purposes only.**

c. *Laying and Arming.*

- (1) Remove mine and fuze assembly (fig. 2-47) from shipping container.
- (2) Inspect mine and fuze for cracks, breaks, or other condition that may render mine unserviceable. If damage is found, replace with new mine.
- (3) Using wrench M22, remove fuze from fuze well by turning fuze counterclockwise until free. Lift up from fuze well (fig. 2-47).
- (4) Check fuze well for foreign matter. If present, remove foreign matter.
- (5) Assure that setting knob is in S (Safe) position and safety clip is in place. If setting knob is not in S position, remove safety clip and

rotate knob to that position and reinstall safety clip. Detonator holder loading assembly must not be in fuze while setting knob is being adjusted.

- (6) Turn fuze bottom-side up and remove white plastic shipping plug from detonator well, using wrench M22 and turning in counterclockwise direction.
- (7) Examine for foreign material and, if present, remove foreign material from opening.
- (8) Visually check position of firing pin. If armed (firing pin centered) (fig. 2-48), reject fuze. If not armed (firing pin point positioned at edge of hole), continue to next operation.

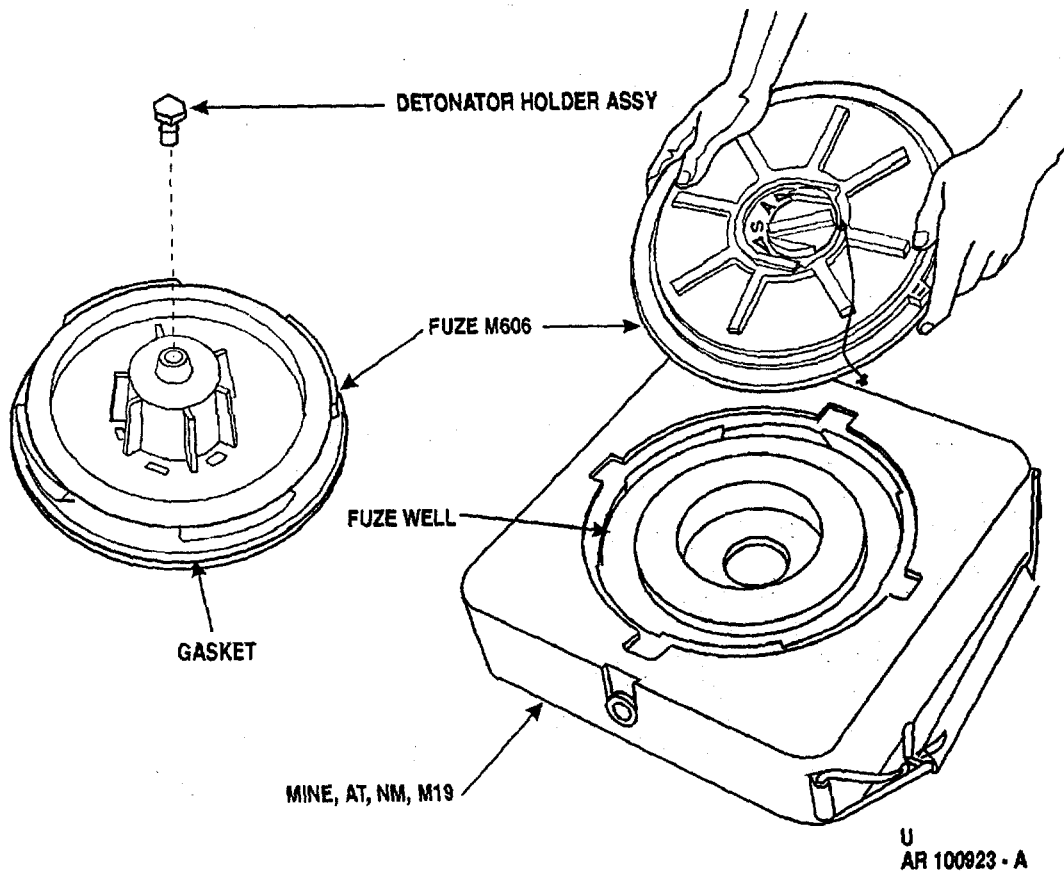
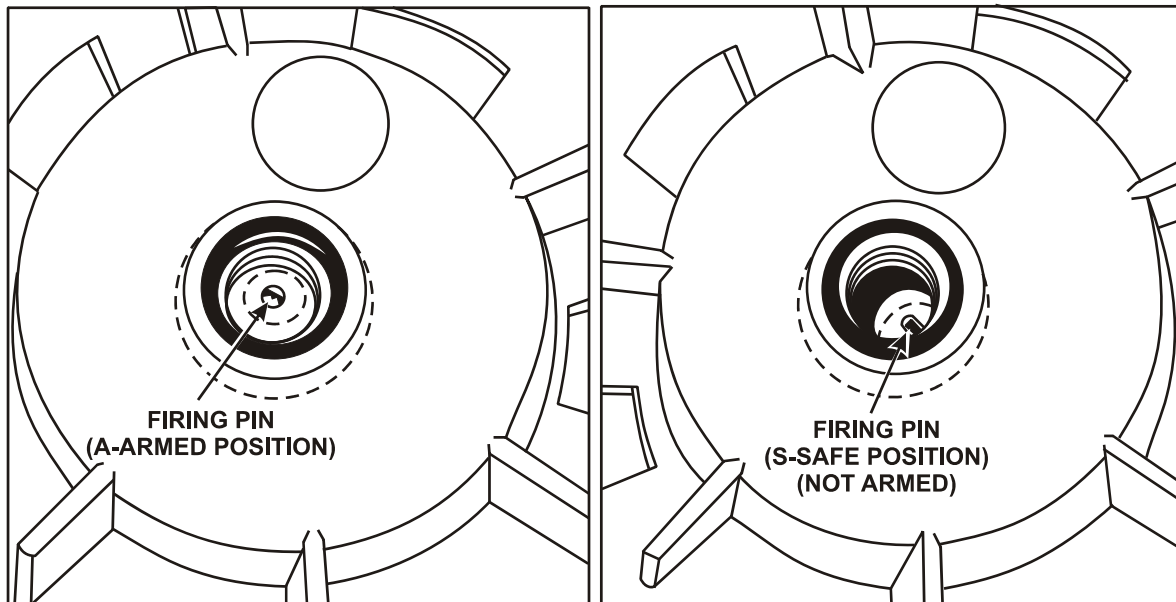

Figure 2-47. Removing fuze M606 from fuze well of mine M19.



AR100924

Figure 2-48. Armed and unarmed firing pin in fuze M606.

- (9) Remove safety clip.
  - (10) Turn to Armed (A) position with wrench M22. *Do not use excessive force* after striking stop. Force used should be enough to overcome the friction load that is felt during the turning from S to A.
  - (11) Visually check position of firing pin. If not armed (firing pin not centered in hole), reject fuze. If armed (firing pin centered in hole), continue to next operation.
  - (12) Turn to Safe (S) position with wrench M22. Observe same precautions with regard to excessive force after striking stop, as indicated in step (10) above.
  - (13) Visually check position of firing pin. If still in armed position (firing pin centered in hole), reject fuze. If not armed (firing pin point at edge of hole), continue with next operation.
  - (14) Replace safety clip.
  - (15) For long term emplacement, smear thin layer of silicone grease G-697 on top of detonator, detonator holder, and threaded portion of detonator holder.
  - (16) Turn fuze bottom side up. Assure that rubber gasket is on fuze.
  - (17) Assemble detonator holder assembly containing detonator M50 in fuze by screwing into detonator well. Tighten assembly by hand and then, using arming wrench, make it secure in detonator well.
  - (18) For long term emplacement, coat detonator holder and 1/2-inch wide area around it with silicone grease G-697 or equivalent.
  - (19) Coat gasket on fuze with silicone grease G-697 or equivalent.
  - (20) Assemble fuze in mine by using arming wrench to turn fuze in clockwise direction.
  - (21) Dig hole approximately 14 inches square and 5 inches deep, with side walls sloping about 45°, to avoid bridging (fig. 2-27).
  - (22) Check bottom of hole and, if ground is soft, provide firm foundation, such as wood board. No steel or metal should be used.
  - (23) Lay mine on firm foundation in hole and at sufficient depth to cover mine with 1-1/2 inches of dirt.
  - (24) For long term emplacement, smear layer of silicone grease G-697 around circumference of fuze where it enters mine.
  - (25) Remove safety clip and, with arming wrench, turn setting knob to Armed (A) position. Observe same precautions regarding turning force as in (10) above. Retain clip for future use, if needed to disarm mine.
  - (26) A force of 300 to 500 pounds on the pressure plate will function the mine.
  - (27) Cover with dirt and camouflage as required, in accordance with FM 20-32.
- d. *Boobytrapping.* Boobytrapping of mine M19 requires antitank mine activator M2, a standard firing device or anti-handling device having a 9/16-inch thread, and tripwire(s).
- (1) Remove closure from one or both activator wells.
  - (2) Assure that each activator well used is free of foreign matter.
  - (3) Remove activator plug and its gasket from head of activator M2. Screw activator hand-tight into activator well of mine.
  - (4) Assure small rubber gasket is in place inside activator. Screw firing device or anti-handling device hand-tight into activator.
  - (5) Install tripwires, as required, fastening them to anchor posts first, then to firing device.
  - (6) For additional information on methods of handling and installing firing devices, see FM 5-250 or TM 9-1345-213-12.
- e. *Disarming and Removal (Neutralizing).*
- (1) Carefully uncover concealed mine and examine side and bottom wells for boobytrapping devices (secondary fuzes).

- (2) If tripwires are found, cut all slack tripwires. DO NOT CUT TAUT WIRES.

**WARNING**

**IF TAUT WIRES ARE ENCOUNTERED WHEN ATTEMPTING TO NEUTRALIZE MINE, DO NOT CUT WIRES UNDER ANY CIRCUMSTANCES. ATTACH LONG ROPE OR WIRE TO MINE WITHOUT DISTURBING TAUT WIRE. THEN, FROM AN UNMINED PROTECTED POSITION, REMOVE MINE CAUTIOUSLY MINE MAY DETONATE BY PULLING ROPE OR WIRE. IF THIS METHOD IS NOT PRACTICABLE, REFER MATTER TO SPECIALLY TRAINED PERSONNEL.**

- (3) Replace all safety pins in firing devices, always replacing positive safety pin first. Refer to TM 9-1375213-12 for instructions pertaining to particular firing device involved.
- (4) Unscrew firing device from activator.
- (5) Unscrew activator. Replace plug and rubber gasket in head of activator. Replace closure for activator well.
- (6) Using arming wrench, disarm fuze M606 by turning setting knob to Safe (S) position.
- (7) Install safety clip in fuze.
- (8) Remove mine fuze by turning counterclockwise, grasping pressure plate with fingers, and lifting up out of fuze well.
- (9) Remove detonator holder assembly from well.
- (10) After the removal of the detonator holder, inspect to assure that firing pin is in the unarmed position (firing pin point positioned at edge of hole). Reject fuze if firing pin is still in the armed position (firing pin point centered in hole).
- (11) Replace shipping plug in detonator well.
- (12) Retape secondary well(s).
- (13) Restore mine and fuze to original position and packing.
- (14) Mine may be emplaced and removed any number of times provided neither mine nor fuze show evidence of damage or deterioration.



f. *Amphibious Use.*

(1) *General.*

(a) Mine M19 is two to three times more effective in water than on land in damaging tracked or wheeled vehicles, because water around a vehicle transmits shock effect better than air. Vehicle support members, as well as tracks and wheels, are damaged by a mine blast. Small vehicles are turned over and almost completely destroyed. Because of the

ability of water to amplify and transmit shock waves, mines equipped with pressure-actuated fuzes are subject to sympathetic detonation at greater distance in water than on land. To avoid sympathetic detonation, mines M19, with fuzes M606, placed in water, must be at least 14 yards apart in 2 foot-deep water and at least 25 yards apart in 5 foot-deep water (fig. 2-49).

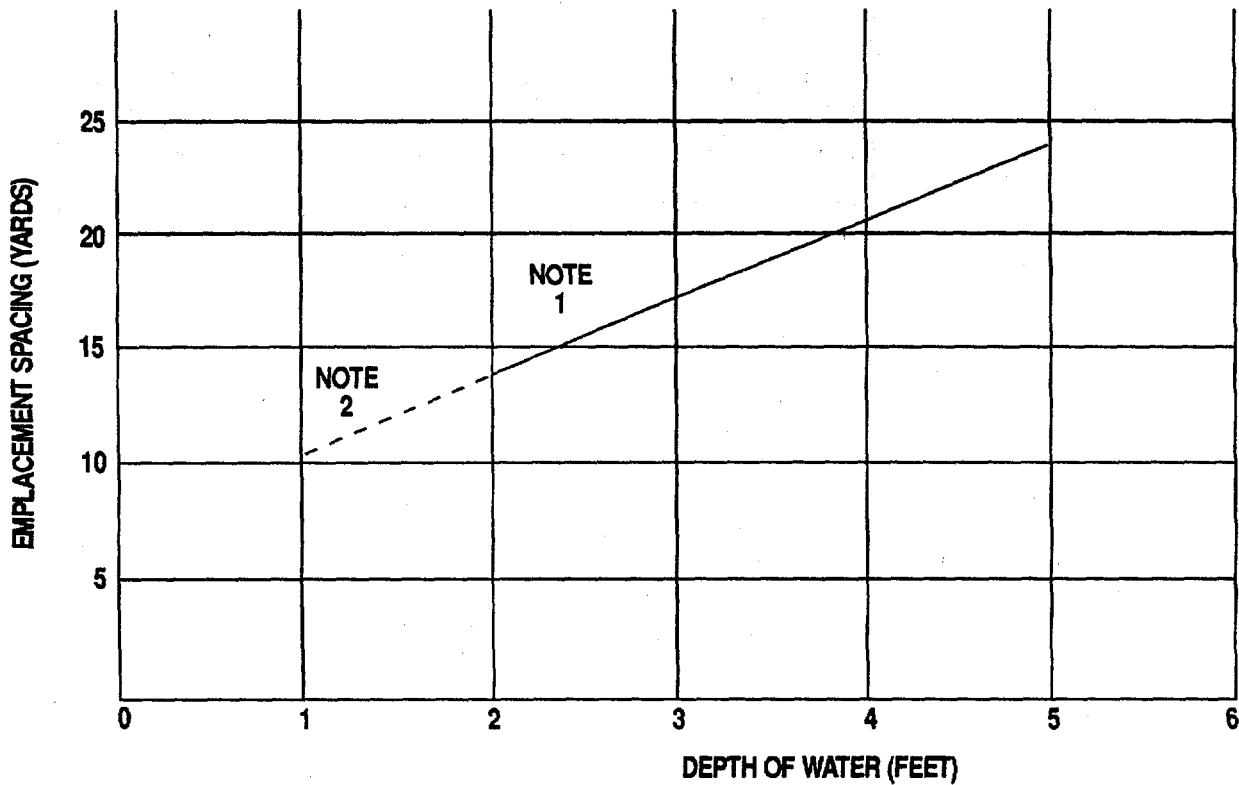

**NOTE 1. SOLID LINE, BASED ON ACTUAL TEST DATA.**

**NOTE 2. BROKEN LINE, EXTRA POLATED DISTANCES;  
NOT CONSIDERED VALID FOR LESS THAN 1-FOOT DEPTH.**

**U  
AR 100928-A**

Figure 2-49. Depth of water chart for emplacement of mine M19.

(b) Choose area to be mined so as to take greatest advantage of the characteristics of the stream and adjacent area. Water depth within minefield should not exceed 3-1/2 feet, since deeper water is difficult to work in and pressure actuated fuzes are usually ineffective against floating vehicles in water deeper than 4 feet. Because of difficulty in maintaining footage and balance in faster flowing water, current velocity should not exceed 3 knots. If the site chosen has a mud bottom, the mud depth should not be greater than 18 inches and there should be a hard base underneath, since the enemy is unlikely to choose a fording-point in which his vehicles can easily become mired. Avoid areas where gravel, rock, stumps, and the like exceed mine size. If such areas are used, prepare field so that mines and their fuzes will be exposed to wheels or tracks or passing vehicles. Since sand in inland waters is continuously moving downstream, it may be difficult to locate and remove mines planted on or downstream from sandbars. Armored vehicles are most likely to enter and exit from streams at points

where incline is 60° or less. After entering stream, they often travel up or downstream for a distance before leaving it. Trail most likely to be followed by vehicles fording stream can be predicted if careful examination is made of natural formation along river banks and location of underwater obstacles is found.

(c) When planting mines in streams and rivers (figs. 2-50 and 2-51), personnel should always work in pairs, and preparation of the mines should be done on land as near to the emplacement site as possible.

(d) All fuze threads and wells should be coated with silicone grease G-697, a waterproof lubricant, a heavy grease, or the like, to minimize chances of water leaking into mine and to ease fuze installation.

(e) For tactical requirements and recording of amphibiously emplaced M19 mines, refer to FM 20-32.

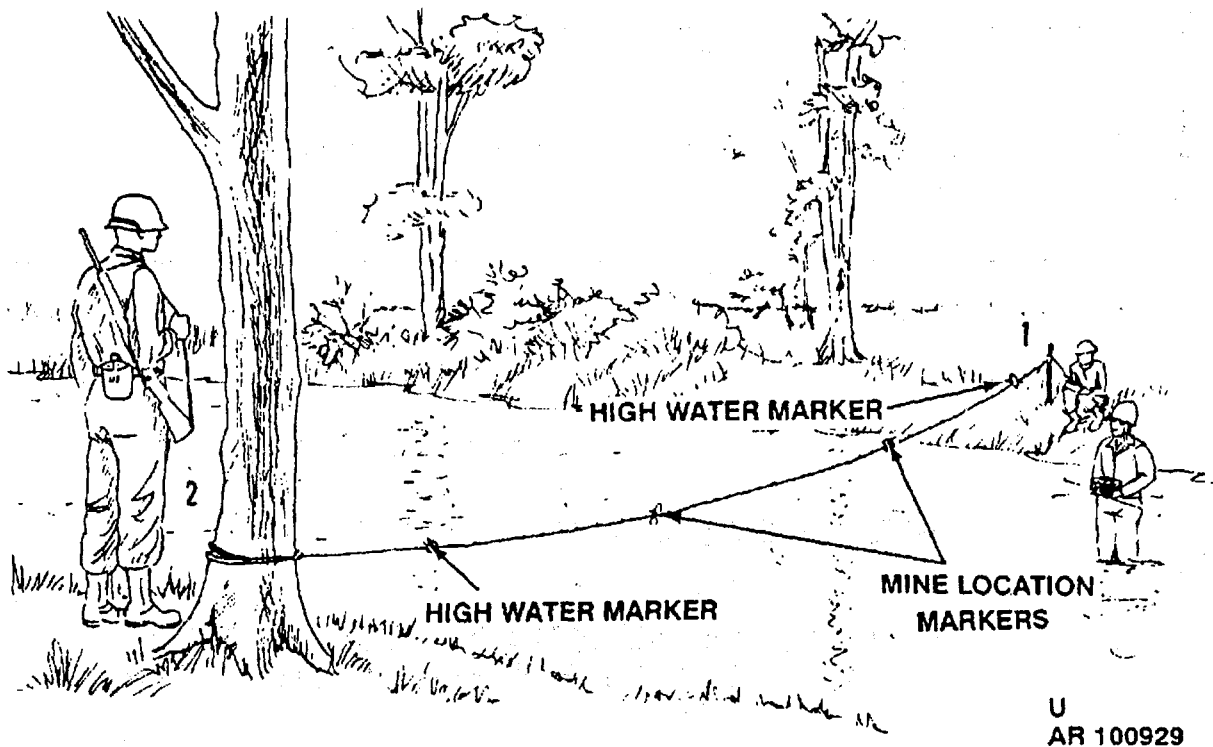
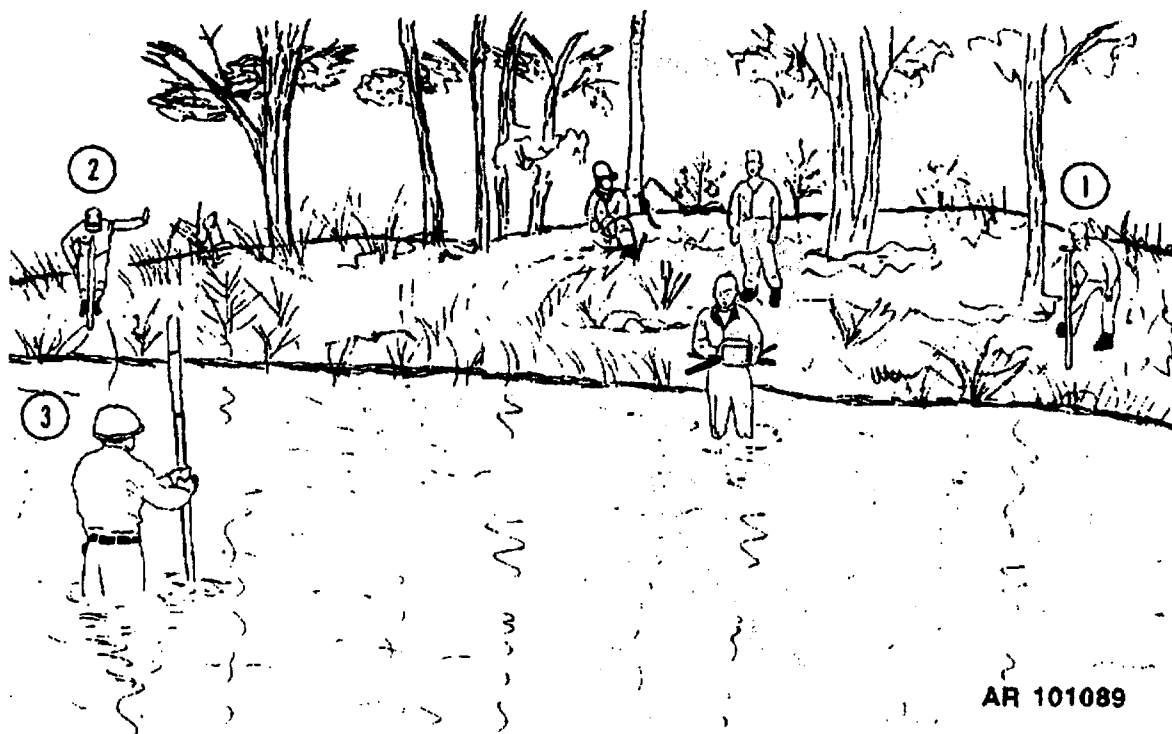

Figure 2-50. Stream and river emplacement of mines M19.



AR 101089

**Figure 2-51. Triangulation method of emplacing mines M19 in streams.**

**(2) Amphibious Emplacement.**

(a) The preliminary procedure for setting up the M19 mine for use in water is the same as the procedure for long term land emplacement, steps (1) (20) in paragraph 2-8c.

(b) In order to prevent movement or drifting of mines emplaced in running water, the mine is stabilized by using the outrigger method. The procedure for this method follows after step c(20) above.

(c) Equipment needed for construction and use of field improvised outriggers are two green limbs, each 3-feet long and 1 inch or less in diameter (barbed wire stakes, signposts, fence rails or similar items having the proper dimensions may be used) (fig. 2-52). Green limbs are recommended because they are stronger and less likely to float than are those which are dried out and dead. In addition, two pieces, each 3-feet long, of clothesline, twine or similar material are required.

1. To prepare outrigger, fasten two 3-foot lengths of green limbs to the underside of the mine and secure with two 3-foot lengths of rope, as shown in figure 2-52.
2. With the fuze in horizontal position, carry the mine to its emplacement position.
3. Approach the emplacement position from downstream side. To prevent dragging the outrigger or contacting objects in the stream, carry the mine by grasping its sides, not by its carrying handle.
4. Place the mine and outrigger on stream bottom.

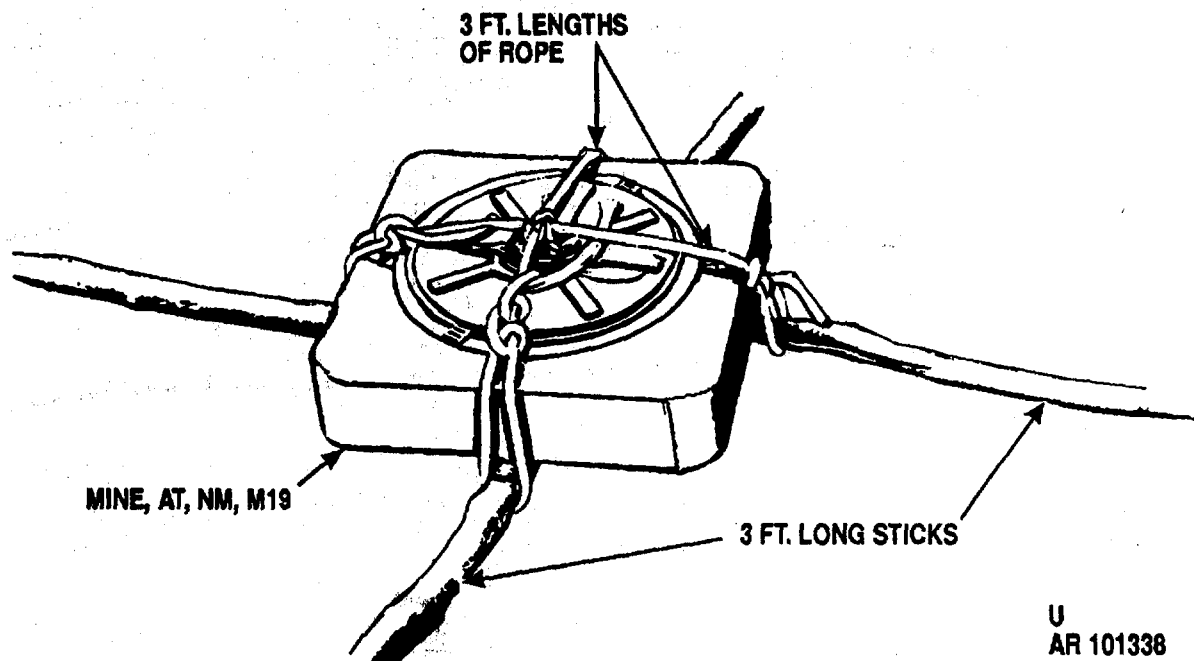

Figure 2-52. Outriggers for amphibious emplacement of mines M19.

5. Remove the safety clip from the setting knob and, using wrench M22, arm the fuse by moving the knob from S to A clockwise.
6. To avoid sympathetic detonation, locate all subsequently emplaced mines in accordance with paragraph f(1)(a).

(3) *Recovery of Amphibiously Emplaced*

*Mines.*

**WARNING**

**MINES MAY HAVE DRIFTED DOWNSTREAM AND/OR CONTAIN ANTIPERSONNEL OR ANTI-HANDLING DEVICES. REMOVAL BY METHODS OTHER THAN EXPLOSIVE BREACHING (TM 91375-21312) IS EXTREMELY HAZARDOUS AND IS NOT RECOMMENDED. IF THE SITUATION DEMANDS SUCH RECOVERY, PROCEED WITH UTMOST CAUTION.**

- (a) Have two-person recovery team proceed slowly and carefully to a point 2 yards below where mine was emplaced.
- (b) Carefully probe for mine.
- (c) Remove any foreign material from its top and, with wrench M22, disarm the mine by turning the setting knob counterclockwise to S position. Insert safety clip.
- (d) Carry the mine to shore.
- (e) Remove fuze from mine by turning with wrench counterclockwise to loosen fuze and, then, grasping the fuze with the fingers, lift out of the fuze well.
- (f) Turn fuze bottom up and remove detonator from detonator well.
- (g) Replace white plastic shipping plug in detonator well.

- (h) Restore mine to original condition and repackage in original packing.
- (i) Mine may be reused provided neither fuze nor mine shows evidence of damage or deterioration.

g. *Emplacement Life.* Emplacement life of mine M19, calculated to 70% effectivity, in various environments, is as follows:

Environment	Emplacement life (months)
Temperature zone – clay soil	55
Temperature zone – sandy soil	75
Tropic zone – with heavy rainfall	9

**2-9. Mine, Antitank: HE, Heavy, M21, with Fuze, Mine Combination, AT M607 (Fig 2-53)**

a. *Casualty Effect and Danger Area.*

- (1) Mine M21 is used primarily for destroying heavy tanks and heavy tracked and wheeled vehicles.
- (2) The mine derives its effectiveness from the action of a steel dish, in the mine, being driven through a tank's belly armor by the detonation of the high-explosive charge of the mine underneath it.
- (3) The blast effect will damage/destroy tank treads.
- (4) Casualties and injuries to personnel will result from the blast effect and the spalling of the tank armor when it is penetrated by the steel dish.

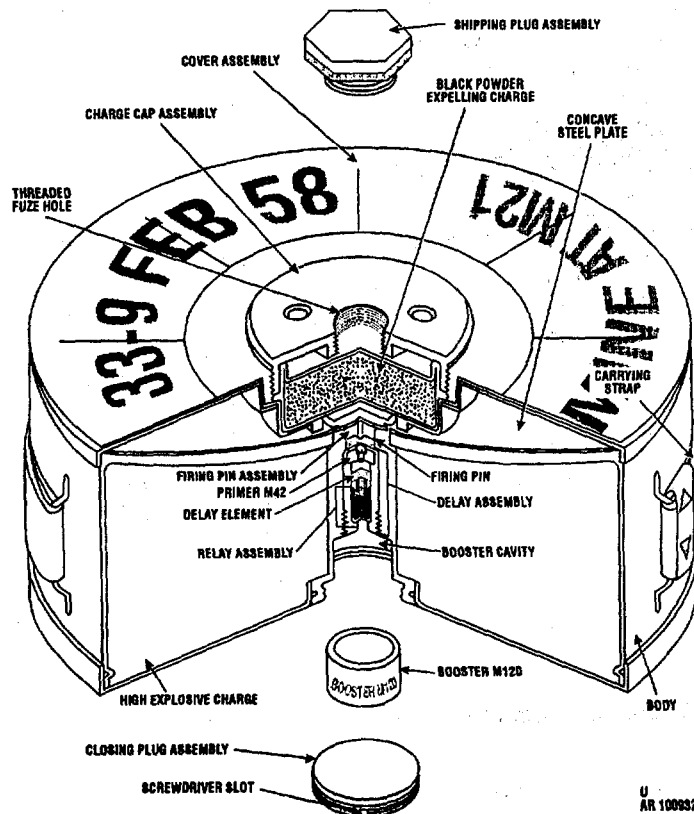

Figure 2-53. Cutaway view of mine, antitank: M21.

b. *Laying and Arming.*

- (1) Remove mine and components from packing box (fig. 2-54).
- (2) Inspect mine and components for serviceability. Check for cracks, dents, or

other signs of damage. If damaged items are found, replace with a new mine.

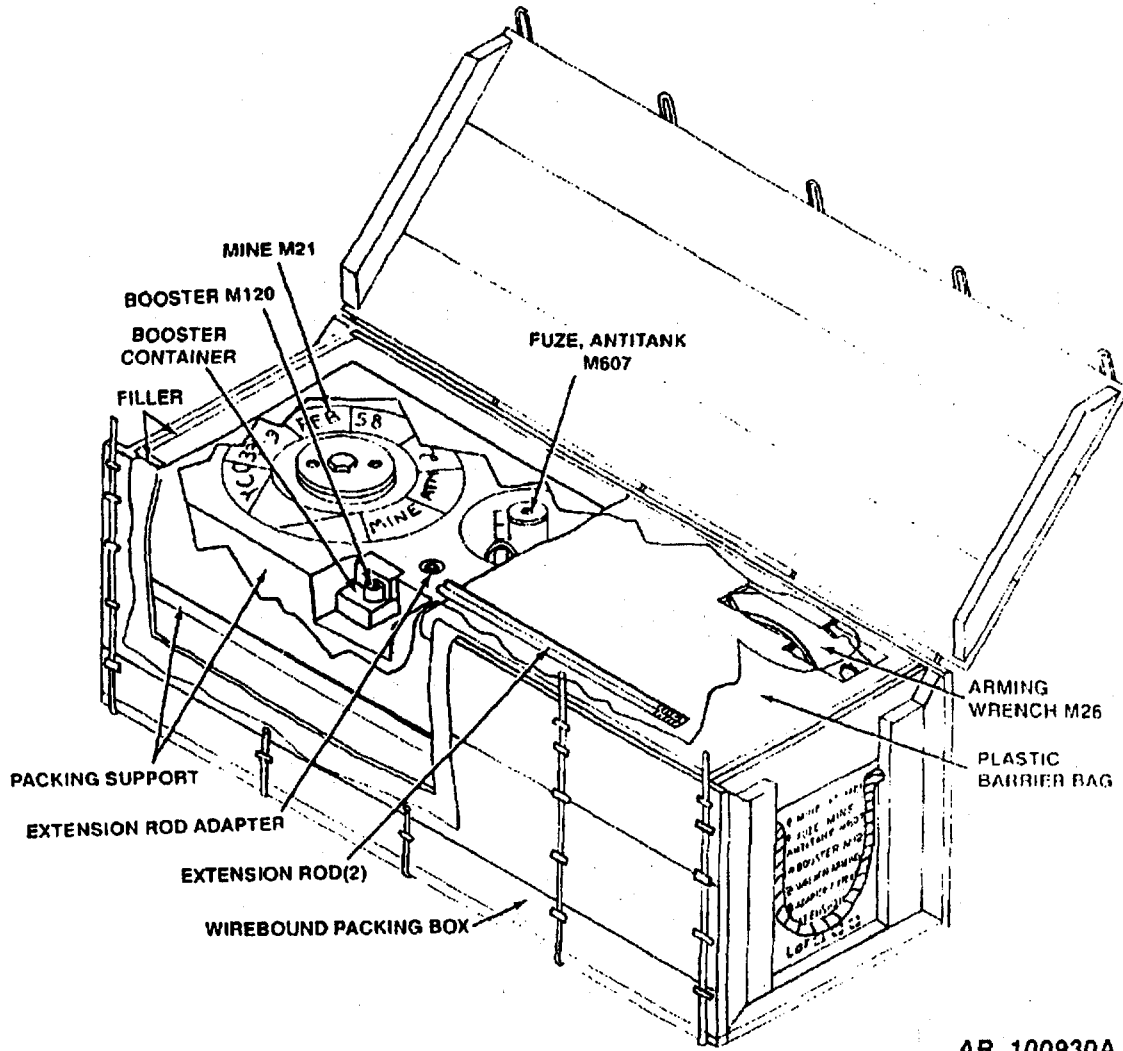

Figure 2-54. Wirebound packing box for mine, antitank: M21 and components.

- (3) Assure that cotter pin of the fuze pull ring assembly and the fuze closure assembly are securely in place (fig. 2-55).
- (4) Turn mine bottom up and, with screwdriver end of wrench M26 (fig. 2-56), remove closing plug assembly (fig. 2-53) by turning counterclockwise.
- (5) Inspect booster cavity for foreign material. Remove, if present.
- (6) Insert booster M120, washer side toward fuze, into booster cavity.
- (7) With wrench M26, replace closing plug assembly by turning clockwise until tight. Gasket of closing plug assembly should be against the booster.
- (8) For long term emplacement, coat threads of closing plug assembly with silicone grease G-697 or equivalent.
- (9) Turn mine bottom down.
- (10) With wrench M26, and using shipping plug end, remove shipping plug assembly from fuze hole cavity of mine.
- (11) Inspect for foreign material. If present, remove from hole.
- (12) For long term emplacement, coat charge gap fuze threads with silicone grease G-697 or equivalent.
- (13) With closure end of wrench M26, remove closure assembly from fuze M607 (fig. 2-55). Gasket on bottom of fuze should remain in place.

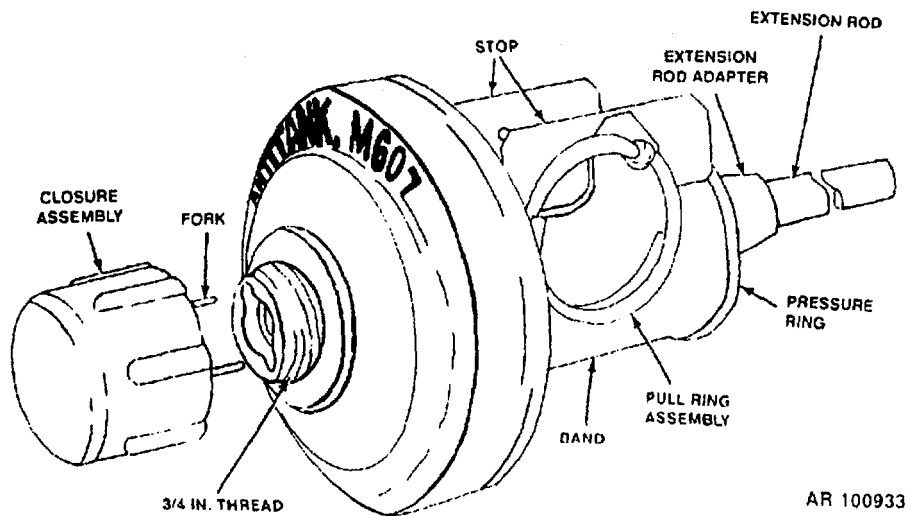

Figure 2-55. Removal of closure assembly from fuze M607.

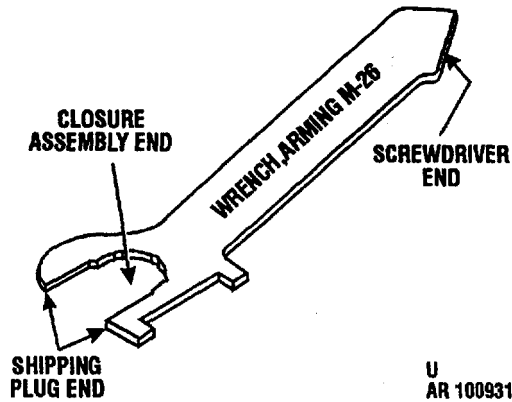

Figure 2-56. Arming wrench M26.

- (14) Screw fuze hand-tight into threaded fuze hole of mine charge cap. Set mine down.
- (15) Prepare hole in ground 10 to 12 inches in diameter and 6 inches deep.
- (16) Check bottom of hole to assure that ground is solid and provides firm, flat foundation for mine to rest on. If ground is soft, mine may tilt and lose effectiveness. In soft ground, place board or flat object under mine to provide firm foundation.
- (17) Place mine in hole.
- (18) Press ground firmly against sides of mine, leaving fuze uncovered.

**NOTE**

Most effective operation is with tilt rod, and it is recommended. However, mine may be set up for pressure operation; proceed to (22) below. For extension rod operation, continue with paragraphs (19), (20), and (21).

- (19) Assemble extension rod into threaded pressure ring of fuze. Adapters originally provided are not required).
- (20) Assure that extension rod is vertical and not tilted in any direction.
- (21) A minimum force of 3.75 pounds on the end of the extension rod or a minimum tilt force of 45 pounds on the side of the pressure ring will initiate the fuze.

- (22) For pressure operation, do not use extension rod assembly. Replace extension rod adapter, if present, in packing box. A force of 290 pounds on pressure ring will function fuze.
- (23) Remove pull ring assembly (fig. 2-57), band, and stop on the fuze. This arms the mine.

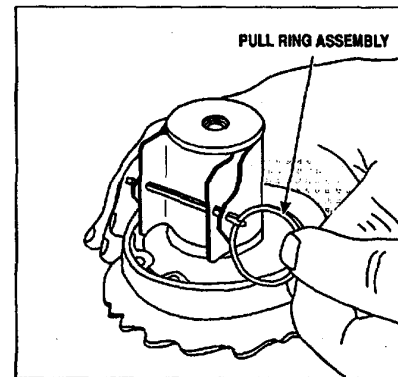

A - PULL RING ASSEMBLY IN PLACE

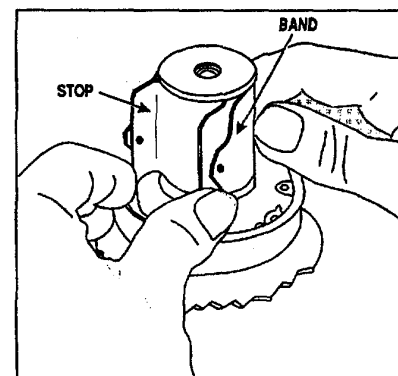

B - BAND AND STOP IN PLACE

U  
AR 100935-A

Figure 2-57. Band, stop, and pull ring assembly in place.

- (24) Retain above items-for future use, if needed, to disarm fuze.
- (25) Camouflage installation in accordance with instructions in FM 2032, being careful not to move extension rod or put pressure on pressure ring. Do not place any material in a position that will prevent movement of extension rod or pressure ring.



c. *Disarming and Removal.*

- (1) Check area for boobytraps. If present, notify EOD personnel.
- (2) If area is clear, approach mine and examine carefully. If extension rod appears tilted or plastic collar is broken, do not attempt to disarm, but call disposal officer.
- (3) Remove camouflage material, being careful not to move extension rod or pressure ring on fuze.
- (4) Slowly and carefully reassemble band, stop, and pull ring assembly on fuze so that pressure ring is immobilized. When cotter pin is in place, spread ends so that it is not easily removable.
- (5) Remove extension rod and extension rod adapter, if present, being careful not to damage rod or adapter.
- (6) Carefully dig around mine so that mine may be removed. If mine has been emplaced with an antihandling device, do not proceed. Using long rope, tie onto mine fuze. Move to secure location and pull mine from hole. If antihandling device has been used, it will explode.
- (7) Remove mine from hole in ground.
- (8) Remove fuze from mine and install closure assembly on fuze.

- (9) Install shipping plug assembly into fuze hole of mine.
- (10) Turn mine bottom up. Remove closing plug assembly from bottom of mine.
- (11) Remove booster, then reinstall closing plug assembly with gasket toward booster cavity.
- (12) Repackage mine, fuze, and components into original container. Place a sheet of craft paper on top of mine to prevent adherence of foam packing material to the mine.
- (13) Mine and components may be reused, if not damaged.

d. *Emplacement Life.* Emplacement life of mine M21, calculated to 70% effectivity, in various environments, is as follows:

Environment	Emplacement life (months)
Temperature zone --- clay soil	40
Temperature zone --- sandy soil	141
Tropic zone --- with heavy rainfall	89

**2-10. Mine, Antitank: HE, M24, with Fuze M404****a. Casualty Effect and Danger Area.**

- (1) Mine M24 (fig. 1-14) is a remotely actuated, horizontal effects system which is designed to defend against tracked and wheeled vehicles. It is only limited in effectiveness based on line of sight deployment.
- (2) The mine uses a 3.5-inch rocket to defeat armor by its shape charge warhead.
- (3) Mine M24 supplements standard vertical effects mines in that off route emplacement of rocket permits mining of locations that previously could not effectively be mined.

**b. Laying and Arming: General.**

- (1) Choose location that will command clear line of fire.

- (2) From road at spot, determined as target impact point, survey terrain with object of positioning launcher at least 10 feet from edge of, and at about 90° angle to, enemy path.
- (3) Place marker (stick, twig, rock, etc.) at estimated target impact point and proceed to position determined best for placement and camouflaging of launcher.

**NOTE**

**Launcher will be positioned with clear view of target point.**

- (4) Unfasten accessories pouch from dispenser pouch (fig. 2-58). Place dispenser pouch on ground at proposed site of launcher.

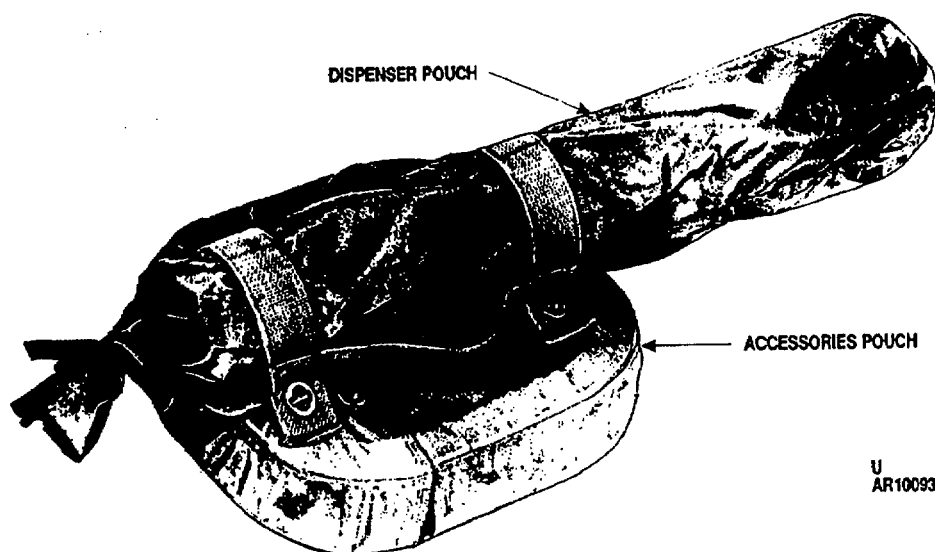

U  
AR100936

**Figure 2-58. Accessories pouch fastened to dispenser pouch (mine M24).**

- (5) Open accessories pouch and remove discriminator spool. Untape top accessories cover and remove firing device and ancillary items from spool (fig. 2-59). Retain all accessories for reuse.
- (6) Remove battery cover from firing device and correctly position two fresh batteries

- in firing device after determining that terminal points are clean (fig. 2-60). Battery polarity must be observed.
- (7) Replace battery cover.

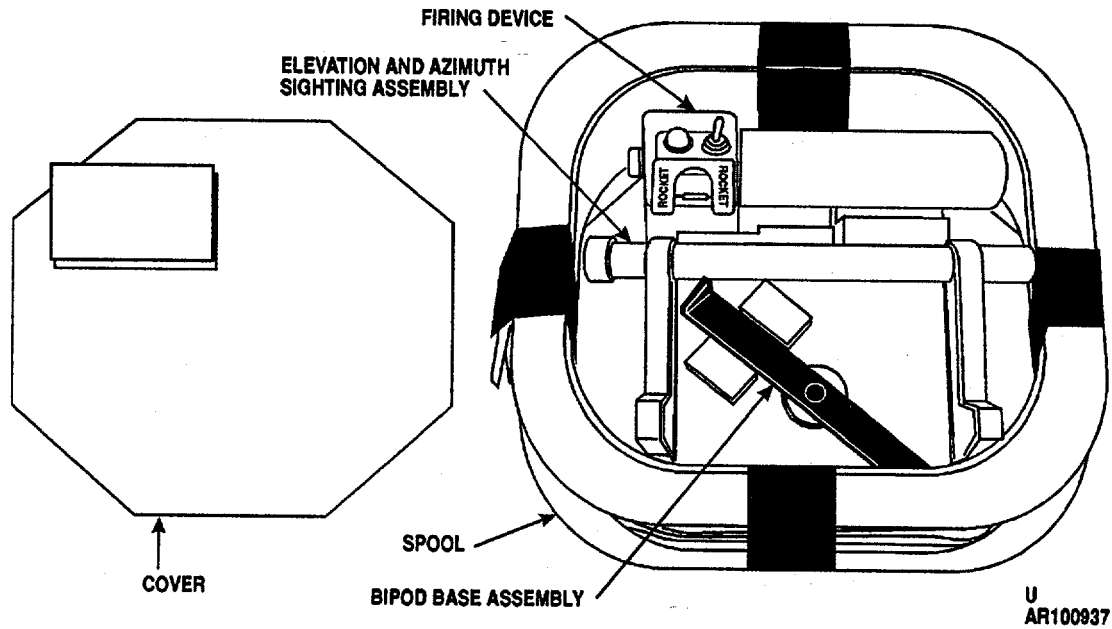

Figure 2-59. Discrimination spool with accessories compartment cover removed (mine M24).

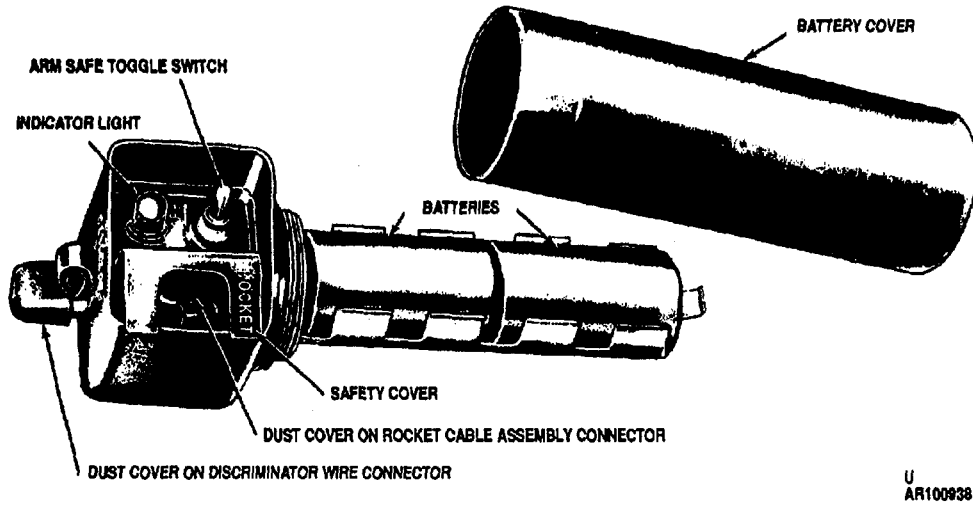

Figure 2-60. Demolition firing device M61.

c. *Laying and Arming: Wheeled or Tracked Vehicles.*

- (1) Follow step b(1) (6), above.
- (2) Unreel discriminator (bead up) (fig. 2-61).

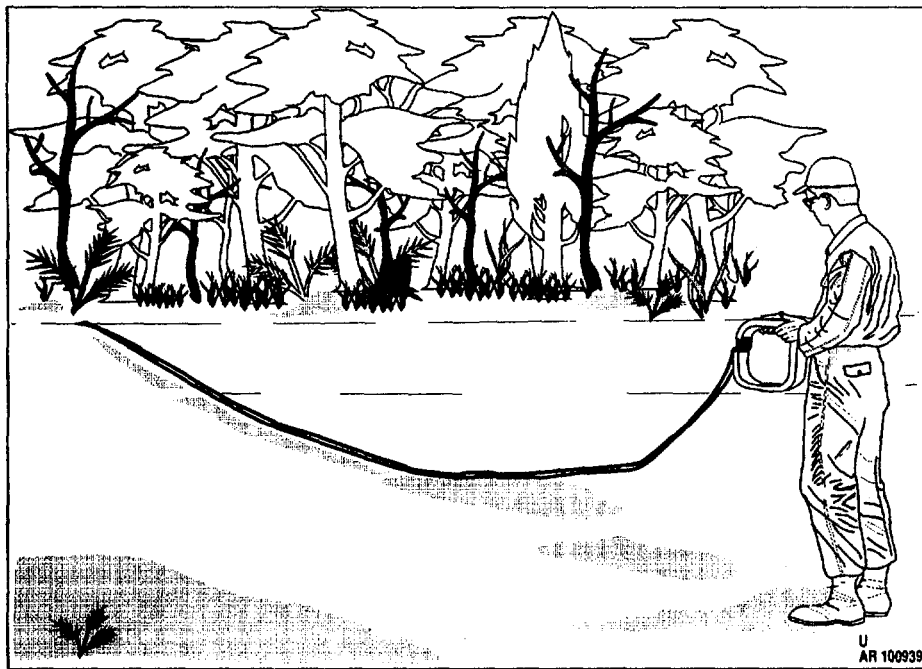
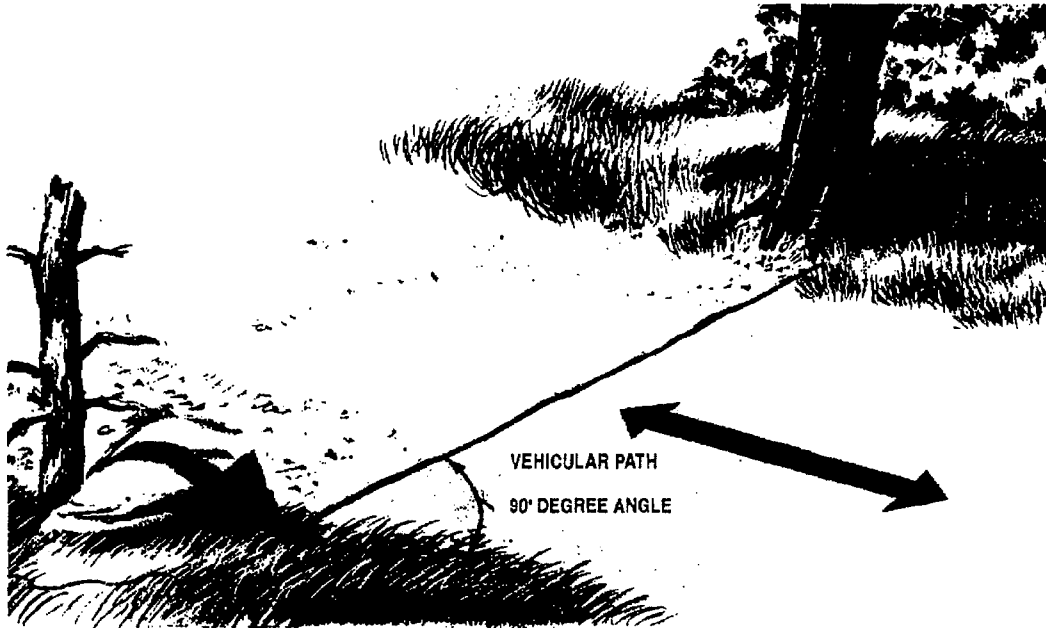

Figure 2-61. Unreeling discriminator.

(3) Starting at far side of road, lay discriminator across and perpendicular to

road through desired point of impact (fig. 2-62).



A - EMPLACEMENT FOR WHEELED AND TRACKED VEHICLES

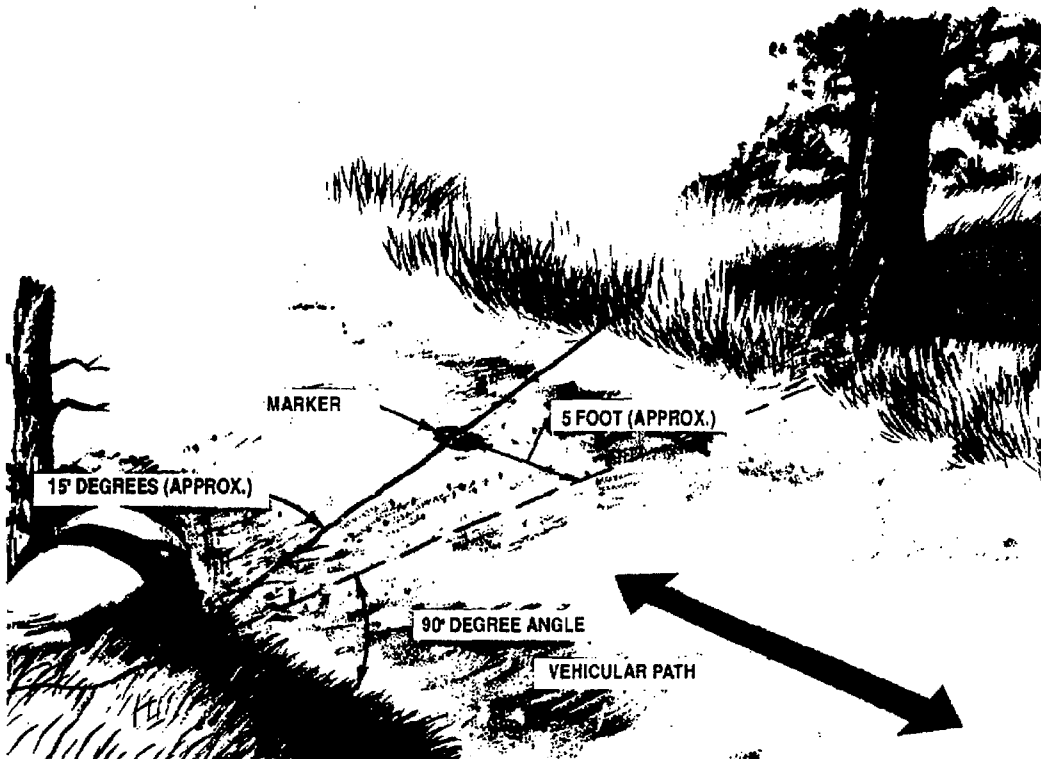

B - EMPLACEMENT FOR TRACKED VEHICLES ONLY

U  
AR100940

Figure 2-62. Emplacement for wheeled & tracked vehicles.

- (4) Adjust discriminator to lie flat with brown painted center markings straddling road center (target impact point).

**NOTE**

**If discriminator is laid over blacktop or cement, advantage may be taken of cracks, crevices, and road joints. Surface dust on dirt roads must be lightly brushed over discriminator. On gravel whatever material is applied to simulate natural terrain must be lightly placed over discriminator.**

d. *Laying and Arming: Tracked Vehicles Only*

- (1) Follow steps b(1) 6, above.
- (2) Return to road edge and place marked (stone, twig, etc.) at side of road, approximating path discriminator would take to form 90° angle to road edge (fig. 2-62).

- (3) Mark off 1.5 meters (5 feet) in one direction along road center from previously marked target impact area.
- (4) Unreel discriminator (bead up) (fig. 2-61).
- (5) Starting at far side of road, lay discriminator across road through mark produced in step (3) and mark produced in step (2) (approximately at 15° angle) (fig. 2-62).
- (6) Adjust discriminator to lie flat with brown painted center marking straddling mark produced at step 3) (new target impact point).
- (7) Camouflage.

**NOTE**

**If discriminator is laid over blacktop or cement, advantage may be taken of cracks, crevices, and road joints.**

Surface dust, on dirt roads, must be lightly brushed over discriminator. On gravel roads, whatever material is applied to simulate natural terrain must be lightly placed over discriminator.

e. *Arming.*

**NOTE**

Proceed as follows for arming after completion of paragraphs b and c above.

- (1) Lay out attached discriminator wire loosely at side of road near discriminator to obtain connector for attachment to firing device.
- (2) Assure ARM-SAFE toggle switch is in safe position. Remove dust cover from firing device connector labeled DETECTOR and connect to discriminator wire (fig. 2-63).

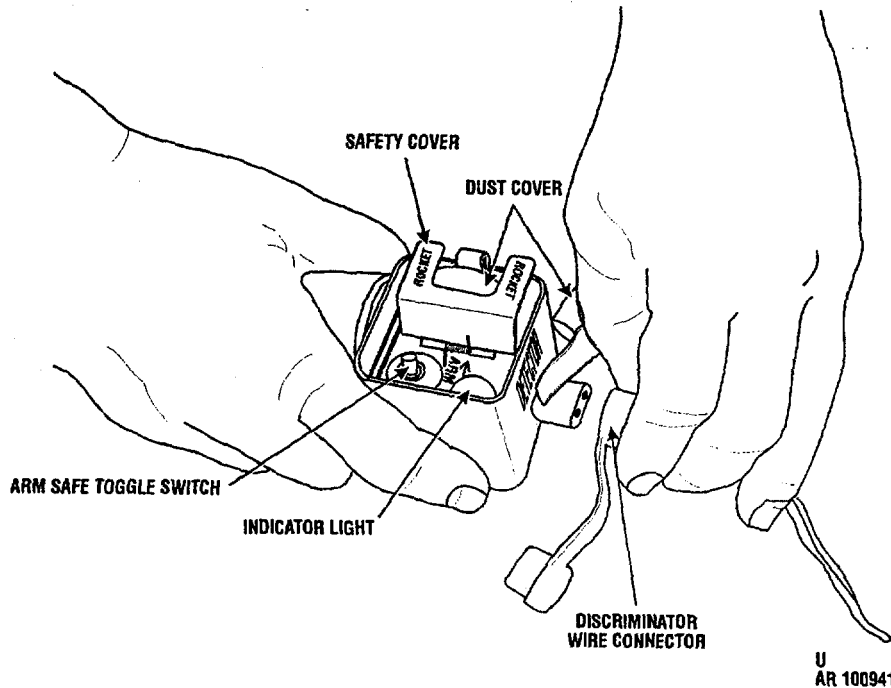

Figure 2-63. Connecting discriminator to firing device.

- (3) Standing on two printed marks on discriminator nearest firing device, test circuitry for completion of electrical contact. Watch indicator light.

**NOTE**

System is operable only if indicator light glows.

- (4) If indicator light does not glow, do not use system.
- (5) If system is operable, temporarily disconnect discriminator wire from firing device.
- (6) Carefully remove launcher from dispenser pouch and place in selected position. (Launcher will operate most effectively at about 90° angle from target road or path at between 3-30 meters (10 to 100 feet)) (fig. 2-64).

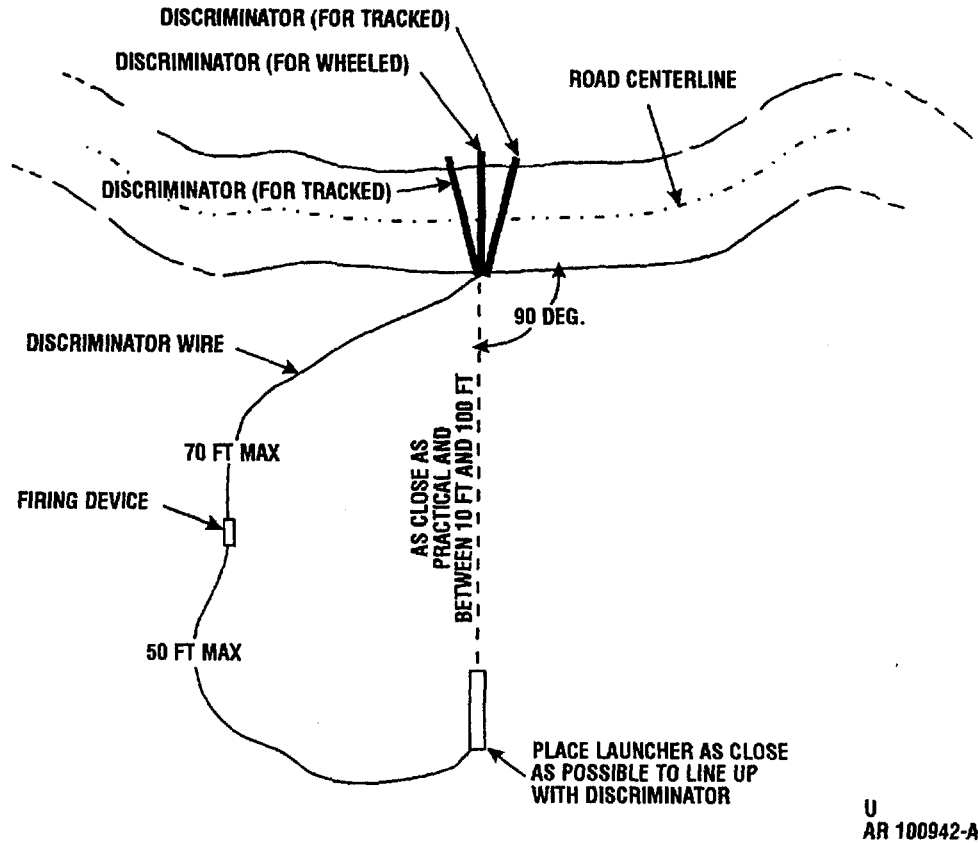

Figure 2-64. Preferred launcher placement.

(7) Remove tape and unwind cable assembly (fig. 2-65).

(8) Position rocket cable assembly for connecting to firing device, approximately same distance as between launcher and target impact point.

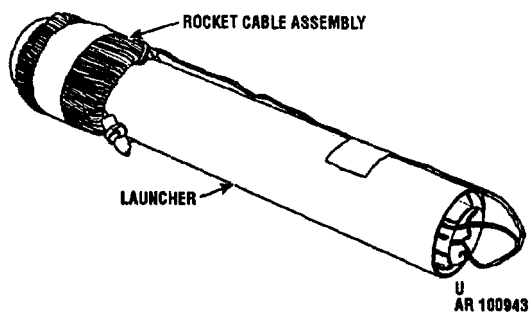

Figure 2-65. Launcher with cable assembly attached to rocket.

**CAUTION**  
 ASSURE THAT FIRING DEVICE IS NOT LOCATED IN LINE OF FIRE AND TAKE CARE NOT TO DISTURB POSITION OF DISCRIMINATOR. DO NOT CONNECT CABLE ASSEMBLY TO FIRING DEVICE AT THIS TIME.

(9) Move to site selected for launcher. Assure that intended launcher position affords clear line of fire to target impact area (fig. 2-64).



f. *Emplacement in Earth, Sand, or Other Loose Material.*

- (1) In soft earth, loose sand, etc., scoop up mound approximately 2 feet in diameter to height of 6 to 8 inches (fig. 2-66).
- (2) Remove circular wooden blocks from launcher end.
- (3) Supporting head of rocket, firmly push rocket slowly forward until safety band is exposed (fig. 2-67).
- (4) Remove safety band.
- (5) Depress ejection pin and push rocket into launcher until ejection pin is held in

depressed position by launcher tube (fig. 2-68).

- (6) Continue to push rocket through launcher until contact rings exposed at aft end. Assure that grounding clip is connected to aluminum grounding ring on rocket (fig. 2-69).
- (7) Remove shorting clip from copper ring by pulling cord of tagged shorting clip and push rocket back into launcher.

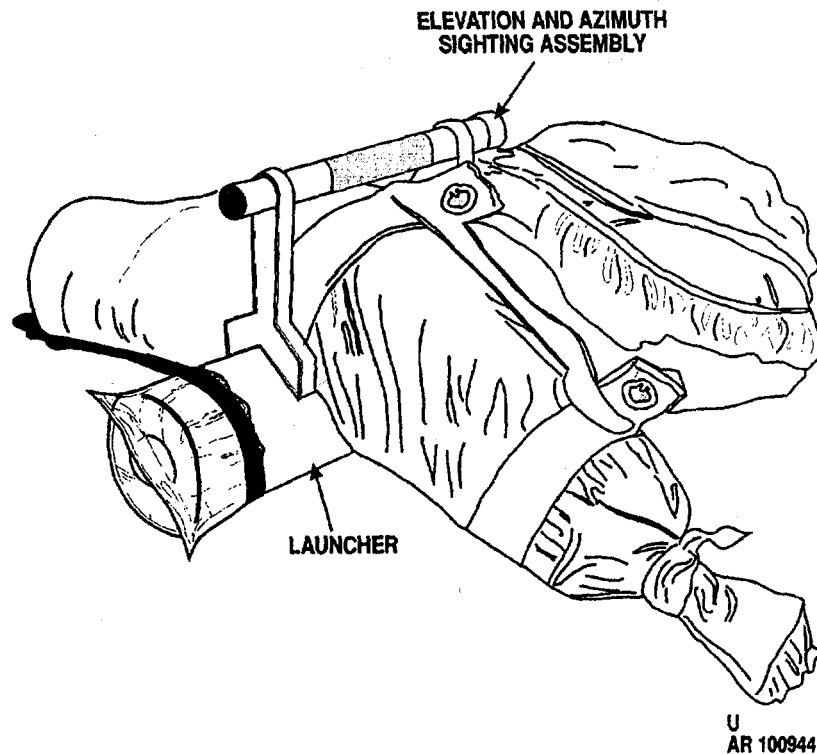

Figure 2-66. Emplaced launcher and sighting assembly, weighted.

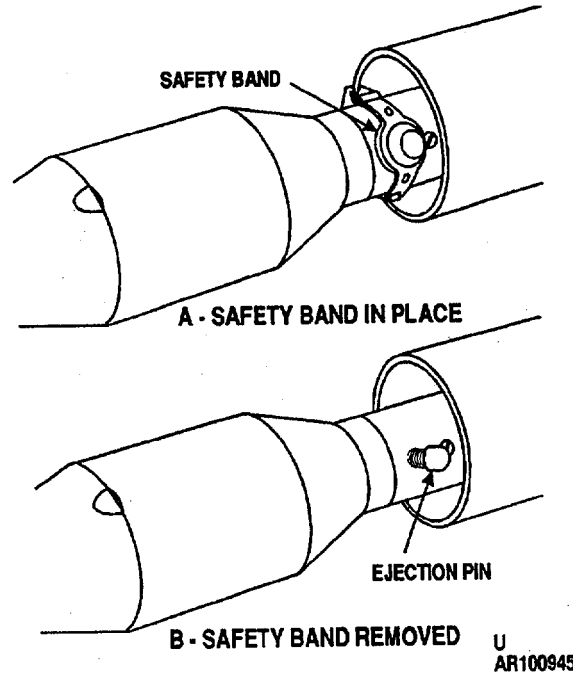

Figure 2-67. Safety band in place and removed.

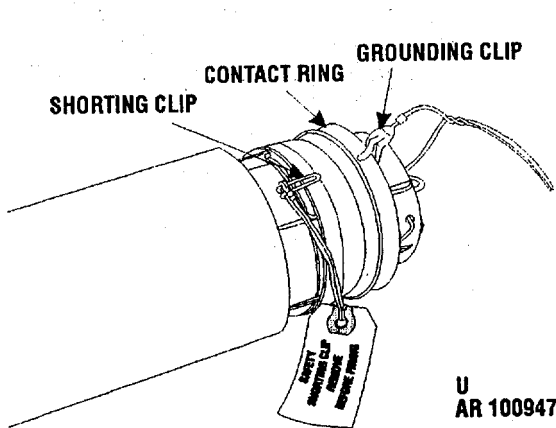

Figure 2-68. Depressing ejection pin.

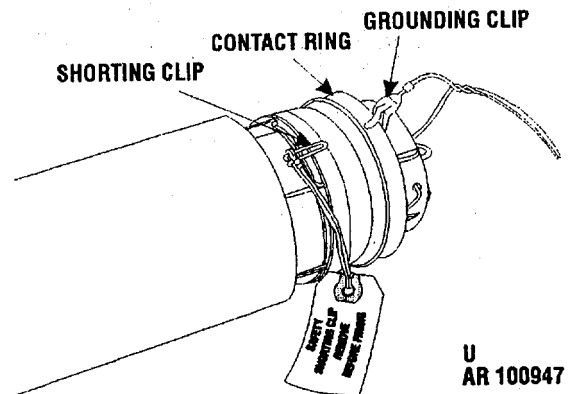
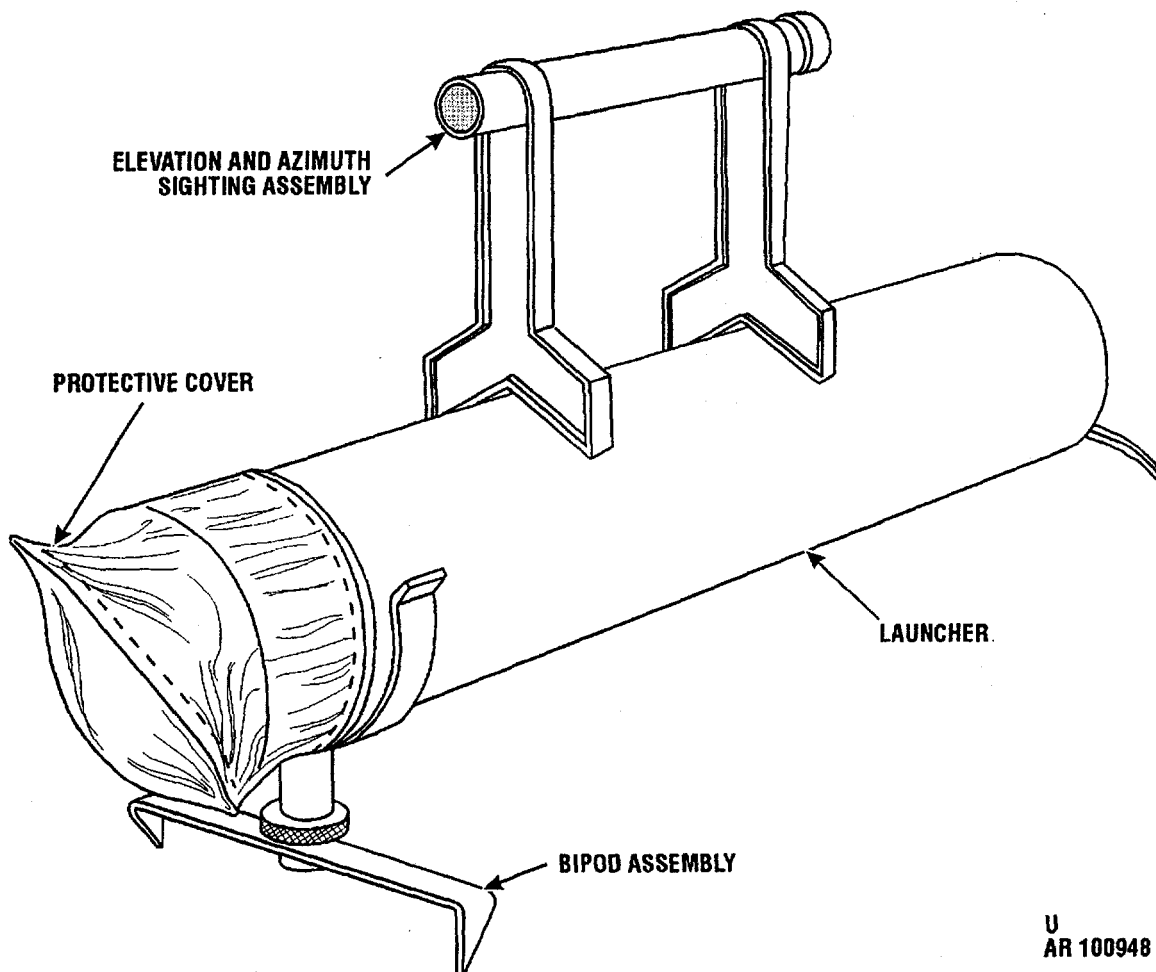

Figure 2-69. Exposed shorting clip.

**CAUTION**  
**DO NOT REMOVE GROUNDING CLIP**

- (8) Place waterproof plastic covers over ends of launcher and tape in position (fig. 2-70).
- (9) Aim launcher in general direction of target impact point and bed down on scooped-up mound.
- (10) Support launcher by packing earth around its sides. Keep forward and aft ends of launcher clear; allow clear area for positioning of sighting assembly.
- (11) Position sighting assembly on launcher surface so that peepsight is aft, and both V-shaped supports of sighting assembly straddle launcher tube circumference. Assure supports rest firmly on launcher tube surface.



U  
 AR 100948

Figure 2-70. Launcher with bipod assembly and elevation and azimuth sighting assembly.

**WARNING**  
**IN POSITIONING PEEPSIGHT, KEEP**  
**HANDS AND ARMS CLEAR OF**  
**LAUNCHER ENDS.**

- (12) Break twig or stick to length of approximately 1 meter (39 inches).
- (13) Return to road center and target impact point, position stick upright at this point (center of discriminator) and support (rocks, sticks, etc.).
- (14) Return to launcher and sight through peepsight of sighting assembly to top of stick. Steady sighting assembly with light touch while sighting. Adjust position of launcher only (proper elevation is achieved by adding or removing earth at aft end), treating both devices as a single unit; position both by manipulating rear of launcher.

**WARNING**  
**IN ALL HANDLING AND SIGHTING**  
**OPERATIONS, REMAIN CLEAR OF**  
**REAR AND FRONT OF LAUNCHER.**  
**SIGHT WITH BODY STRETCHED AT**  
**RIGHT ANGLES TO LAUNCHER.**

- (15) Temporarily remove sighting assembly.
- (16) Fill dispenser pouch with loose earth to about 6 inches from top to allow for tying. Fill accessories pouch with loose earth so as to allow for closing and snapping of cover.
- (17) Close both pouches.
- (18) Lay dispenser pouch across launcher about 1 inch to rear of forward taped plastic cover.
- (19) About 2 inches aft of dispenser pouch, place accessories pouch over launcher. Rear of launcher must remain clear.
- (20) Reposition sighting assembly, straddling dispenser pouch. Assure legs of sighting assembly are positioned on launcher and are not caught in or resting on pouch, plastic cover, dirt or tape.

- (21) Reconnect firing device to discriminator and assure that indicator light is not lit.
- (22) If light is lit, check and straighten any kinks or twists in discriminator that could cause enough pressure to complete electrical circuitry.
- (23) If light continues to glow, do not use system.
- (24) If light goes out, proceed with next step.

**NOTE**  
**All traces of implanted mine system**  
**must be carefully camouflaged.**

- (25) Recheck camouflaged discriminator, disguising any exposed section.

- NOTE**
- **Avoid applying pressure to, or changing position of, discriminator. All other components of system must be disguised.**
  - **Make final check through sighting device to assure that proper aim has been maintained. If aim has not been maintained, adjustments may be made by carefully manipulating rear of launcher. Then remove sight and camouflage light. Remove sighting stick.**

- (26) Remove dust cap from rocket cable assembly connector; lift up safety cover and remove dust cap on firing device connector labeled ROCKET; and join connectors (fig. 2-63).

**WARNING**  
**DO NOT ATTEMPT TESTING AFTER**  
**ROCKET CABLE ASSEMBLY IS**  
**CONNECTED TO FIRING DEVICE.**

- (27) Throw toggle switch to ARM position.

**WARNING**

**MINE SYSTEM IS NOW FULLY ARMED AND WILL FIRE WHEN PRESSURE IS APPLIED TO DISCRIMINATOR. STAND CLEAR OF FRONT AND REAR OF LAUNCHER (Fig. 2-71).**

g. *Emplacement on Rock, Shale, etc.*

- (1) If rocky terrain or suitable mound cannot be formed to support launcher, use bipod assembly.

- (2) Complete steps f(2) (8), above.
- (3) Affix bipod base assembly to bipod clip on forward portion of launcher immediately behind taped plastic cover.
- (4) Generally aline launcher in direction of target impact point and set firmly on bipod assembly. Force bipod spikes to take advantage of whatever grip is available. Allow forward end of launcher at least 5 inches clearance from ground.

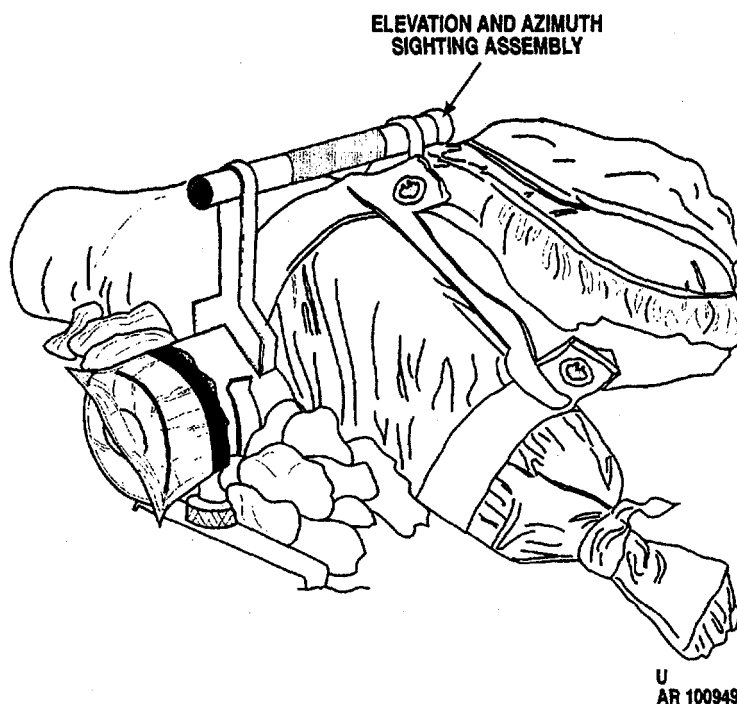

**Figure 2-71. Emplaced launcher and sighting assembly with bipod weighted.**

**NOTE**

**A knurled, threaded assembly on bipod assembly allows for elevation adjustment.**

- (5) Support launcher by packing available earth, rock, gravel, etc., around sides of launcher. Keep forward and aft ends of launcher clear.

- (6) Follow steps f(11) (15), above.
- (7) Fill dispenser pouch with whatever anchoring material (earth, rock, gravel, etc.) is available, to about 6 inches from top to allow for tying. Fill accessories pouch so as to allow for easy closing.
- (8) Close both pouches.
- (9) Follow steps f(18) (27), above.

**WARNING**

**MINE SYSTEM IS NOW FULLY ARMED AND WILL FIRE WHEN PRESSURE IS APPLIED TO DISCRIMINATOR. STAND CLEAR OF FRONT AND REAR LAUNCHER.**

h. *Disarming and Removal.*

- (1) Carefully remove camouflage from firing device and throw toggle switch to SAFE position.
- (2) Disconnect rocket cable assembly from firing device.
- (3) Replace connector dust cap at end of rocket cable assembly.
- (4) Remove camouflaging material from launcher.
- (5) Rewind rocket cable assembly and place at side of launcher.
- (6) Remove waterproofing covers from ends of launcher.
- (7) Push rocket back through launcher until copper ring is exposed. Replace tagged shorting clip on copper ring just forward of aluminum grounding ring.

**WARNING**

**COMPLETE ABOVE STEPS BEFORE PROCEEDING.**

- (8) Firmly support rocket warhead to prevent launcher damage. Push rocket nose out of launcher until ejection pin to rear of warhead is exposed. Place safety band over ejection pin and secure; push rocket back into launcher.
- (9) If bipod base assembly was used, remove; wind rocket cable assembly around, and tape to launcher.
- (10) Replace circular packing blocks in launcher.

- (11) Unload and shake out accessories pouch and dispenser pouch, but not in vicinity of launcher and components. Keep entire system as clean as possible.
- (12) Pack launcher in dispenser pouch.
- (13) Disconnect discriminator from firing device, and replace dust caps.
- (14) Rewind discriminator device and wire onto spool.
- (15) Remove batteries from firing device. Unless immediate use is intended, discard batteries.
- (16) Place bipod base assembly, waterproofing covers, sighting assembly, and firing device in accessories compartment and tape on covers.
- (17) Slide discriminator spool into accessories pouch.
- (18) Fasten accessories pouch and dispenser pouch together.

**NOTE**

Item may now be retained for reuse.

i. *Emplacement Life.* Emplacement life is not applicable to the 3.5-inch rocket. However, the effectivity of the mine M24 system is dependent on the life and efficiency of the batteries in the arming device M61.

## **2-11. Mine, Antitank, Practice: Heavy, M12A1 and M20**

a. Figures corresponding to these mines are found in paragraph 2-7 (mine M15). Practice mines M12A1 and M20 simulate mine M15, except for the use of practice fuze M604 instead of the M603. Practice fuze M604 operates similarly to the M603 except that on initiation a smoke charge functions, emitting a cloud of smoke and creating a noise which indicates the functioning of the mine.

b. Procedures for laying and arming, boobytrapping, disarming and removal (neutralizing), and refuzing procedures for these mines are as follows:

- (1) Mine, antitank, practice: heavy, M12A1 (fig. 1-16).

(a) *Casualty effect and danger area.*

1 Mine M12A1 is used in the training of personnel in the proper method to be observed in the care, handling, and use of heavy service antitank mines. It is shipped empty and filled in the field with sand to simulate weight of service mines.

2 Practice fuze M604 and practice activator M1 contain smoke charges to simulate functioning of the mine. Personnel are warned to be clear and under cover when mine functions, since smoke charges explode to emit a cloud of smoke and a loud noise.

(b) *Laying and arming.*

- 1 Remove mine from packing.
- 2 Examine for cracks, dents, or other signs of unserviceability. If damage is found, replace mine with new one.
- 3 Using arming plug wrench M20 (fig. 2-20), unscrew arming plug from mine.
- 4 Inspect fuze well and arming plug threads for presence of foreign material and, if present, remove. Presence of water in fuze well can be dangerous in areas where temperature drops below freezing and ice forms.
- 5 Remove fuze M604 from its metal shipping container and inspect for serviceability. If evidence of unserviceability is found, replace fuze with new one.
- 6 Use hook end of arming wrench to remove safety fork from cover assembly of fuze. Save safety fork (clip) for use in disarming fuze.

- 7 Insert fuze gently into primary fuze well of mine until it seats firmly. Avoid pressure on pressure plate of fuze when inserting fuze into fuze well. Assure proper clearance between fuze pressure-plate button and shutter of arming plug, by fully seating on internal shoulder of mine fuze well.

**NOTE**

Because of tolerances permitted in the manufacture, the pressure plate of the fuze M604 may interfere with the movement of the arming plug. The shutter moves from an outside to a center position as the arming knob is turned from the SAFE to the ARMED position. To predetermine whether there will be proper clearance, an arming wrench M20 of recent manufacture, with a depth gage consisting of a lip projecting from its side, is provided. Use the depth gage as instructed in paragraphs 8 and 9 below.

- 8 After insertion of the fuze into the fuze well of the mine, and before screwing the arming plug into place, lay the arming wrench on its side on top of the pressure plate of the mine so that the depth gage extends into the fuze well towards the fuze.
- 9 When the end of the gage touches the pressure plate of the fuze, it indicates improper clearance. The lack of proper clearance can be remedied by screwing the arming plug into the mine slightly less than its full normal distance so that the arming plug shutter can be moved freely to the ARMED position. Never leave setting knob pointed to DANGER.
- 10 With setting knob and shutter in SAFE position, screw arming plug into mine (see NOTE above).
- 11 Dig 15-inch diameter hole, approximately 5-6 inches deep, with sides sloping approximately 45 degrees.

12. Lay mine on firm foundation with top surface of pressure plate not more than 3 inches beneath ground level.
13. Just before mine is covered, arm mine, using arming wrench, by turning setting knob red pointer from SAFE through DANGER to ARMED. Do not attempt to force setting knob to Armed position.
14. Camouflage mine in accordance with instructions in FM 20-32.

(c) *Boobytrapping.* Boobytrapping of mine requires a practice activator, the correct primed firing device, and one or more tripwires.

1. Remove tape and shipping sleeve from secondary fuze well (side well, bottom well, or both).
2. Inspect secondary fuze well carefully to assure it is free of foreign matter.
3. Remove plug and its gasket from head of practice activator M1; screw activator hand tight into secondary fuze well of mine.
4. Assuring that small rubber gasket is in place inside activator, screw firing device hand tight into activator. (Firing device requires no blasting cap when used with activator).
5. Install tripwires, as required.
6. Arm firing device by removing its safety pins, always removing positive safety pin last.
7. Save safety pins, activator plug and its gasket for use in disarming and removal.

(d) *Disarming and Removal (Neutralizing).*

1. Carefully uncover concealed mine. Examine side TM 9-1345-203-12 and bottom secondary fuze wells for

boobytrapping devices (secondary fuzes). Tripwires may have been installed, which will initiate secondary fuze by either pull or release.

2. Cut all slack tripwires. Do not cut any taut tripwires.

**WARNING**

**IF TAUT TRIPWIRES ARE ENCOUNTERED WHEN ATTEMPTING TO NEUTRALIZE MINE, DO NOT CUT WIRES UNDER ANY CIRCUMSTANCES. ATTACH LONG ROPE OR WIRE TO MINE WITHOUT DISTURBING TAUT WIRE. THEN, REMOVE MINE CAUTIOUSLY MINE MAY DETONATE BY PULLING ON LONG ROPE OR WIRE FROM PROTECTED POSITION. IF THIS METHOD IS NOT PRACTICABLE, REFER MATTER TO SPECIALLY TRAINED PERSONNEL.**

3. Replace all safety pins in firing devices, always replacing positive safety pin first. Refer to TM 9-1375-213-12 for instructions pertaining to particular firing device involved.
4. Unscrew firing devices from activator.
5. Unscrew activator. Replace plug and its gasket in head of activator.
6. Turn setting knob of arming plug to SAFE position.
7. Remove arming plug by unscrewing in counterclockwise direction.
8. Remove fuze by grasping fuze pressure plate with fingers. Fuze should come out easily. Do not attempt to remove fuze if frozen in place.
9. Insert safety fork (clip) in fuze.



10. After removing fuze, screw arming plug back into place, hand tight, with pointer on setting knob pointing to SAFE.
11. Remove tripwires and replace tape over secondary fuze well.
12. If required, remove sand from mine.
13. Restore mine and fuze to original position and packing.
14. Mine may be laid and removed any number of times, provided neither fuzes nor mines show evidence of damage or deterioration.

(e) *To Reuse Functioned Mine and*

*Fuze.*

1. If mine and fuzes have functioned and mine casing is undamaged, replace main fuze and practice activator with new ones.

2. Retain firing mechanism of firing device. Base coupling with fired primer should be replaced. Firing mechanism may be recocked by placing end of stick, pencil, or nail against firing pin and pushing back until it is held in place by release pin.
3. Install safety pin.
4. Restore mine, new fuze, new practice activator, and firing device to original condition and packing.

(2) *Mine, Antitank, Practice: Heavy, M20 (fig. 1-17).* Laying and arming, boobytrapping, functioning, disarming, removal (neutralizing), recovery, and refuzing procedures for the practice mine M20 and practice fuze M604, are similar to those found in paragraphs b(l) (a) through (e).

## CHAPTER 3 OPERATOR MAINTENANCE INSTRUCTIONS

### Section I. SERVICE UPON RECEIPT OF MATERIEL

#### 3-1. General

a. Upon receipt of mine materiel, verify each packaged item against the requisition list.

If marking on packaging conflicts with nomenclature on requisition, check with ammunition supply personnel to determine if an issue error has been made.

b. Unless packing boxes show evidence of moisture or damage to the extent that contents may be unusable, do not open until materiel is to be used.

c. All standard precautions for care and handling of ammunition are applicable to mine items.

#### 3-2. Unpackaging Precautions

##### a. Inspection.

(1) Inspect markings on packaging for legibility of lot number. If illegible, open box, note lot number stenciled on inner pack or item, and restore illegible numbers.

(2) Visually inspect each box/container for damage or indication that the contents may be damaged.

(3) Unpack only as far as necessary to determine the serviceability of the materiel. Do not open undamaged barrier bags or juggle wrapped containers.

(4) If outer box/container is damaged beyond repair, transfer contents to a serviceable box/container and mark accordingly.

(5) If necessary, visually inspect each item according to procedures in chapter 4.

(6) If barrier bags are damaged but ammunition is serviceable, repackage per paragraph 4-9 and give priority of issue.

(7) Operator personnel will repack unused items in original serviceable outer containers to preserve their serviceability.

#### NOTE

**Save some boxes and packing material for immediate re-use. Contact Direct Support Maintenance for disposition of remainder of boxes.**

b. *Pallets.*

#### WARNING

**WEAR GLOVES AND SAFETY GLASSES OR GOGGLES WHEN CUTTING STRAPPING. AVOID BEING STRUCK BY ENDS OF STRAPS WHEN TENSION IS RELEASED.**

c. *Wirebound Boxes (fig. 3-1).*

- (1) Cut lead seal wire with pliers and remove.
- (2) Bend wire loops up straight using a salee closer (fig. 3-2), screwdriver, or pliers.
- (3) Lift lid panel to open box.
- (4) Remove top, packing (if any) from box.
- (5) Remove inner packs.

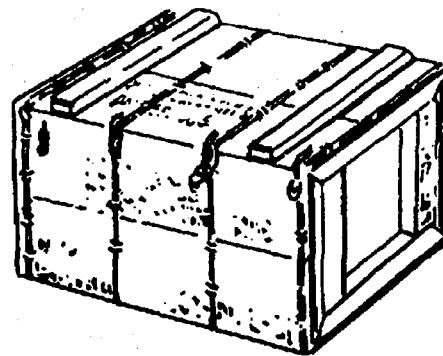

CLOSED AND SEALED

AR 100793

Figure 3-1. Typical wirebound box.

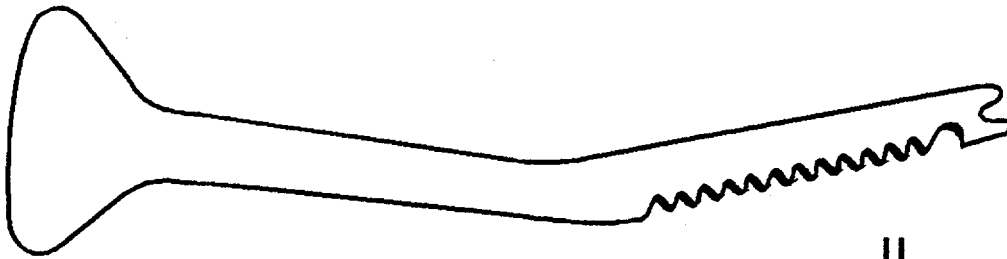

**U**  
**AR 5648**

**Figure 3-2. Sallee Closer.**

d. *Wood Boxes with Hasp and Hinge.*

- (1) Cut steel strapping with metal cutting shears.
- (2) Remove and dispose of straps.

**WARNING**

**TO PREVENT INJURY, RELEASE TENSION BY PRESSING DOWN ON TOP OF BOX WHILE CUTTING STRAPS ON SIDE OF BOX.**

- (3) Cut lead seal wire with pliers and remove.
- (4) Turn catch and open hasp.

- (5) Lift box top to open.
- (6) Remove top padding/filler (if any) from box.
- (7) Remove inner pack(s). Fiber Containers (fig. 3-3).
- (1) Remove sealing tape(s) by pulling end tab or tear strip.
- (2) Twist end cap and pull off. If container has two end caps, do not remove second end cap until contents have been removed from the open end.
- (3) Remove any padding pieces from container.
- (4) Remove contents by pulling out item. Container may be tilted to allow item to slide out far enough to be grasped by hand.

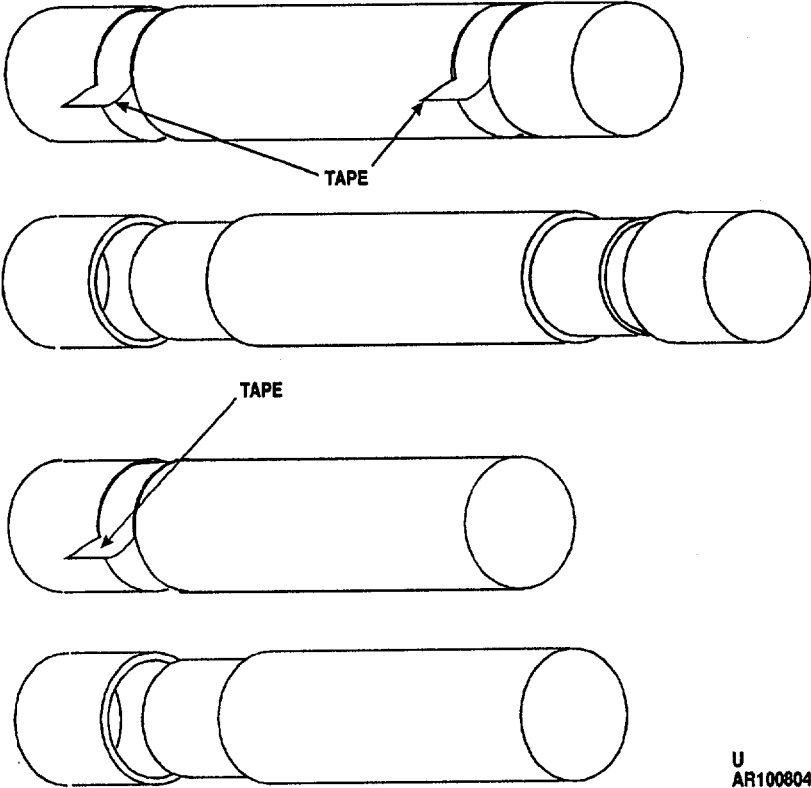

U  
AR100804

Figure 3-3. Typical fiber containers.

- f. *Vapor Barrier Bags.*
- (1) Cut barrier bag open along the edge with most excess material as close to seal as possible.
  - (2) Cut or remove tape from inner container.
  - (3) Open container and remove padding, if any.
  - (4) Remove items. If all items are not removed, close and seal package following procedures in Chapter 4.
- g. *Ammunition Metal Container (fig. 3-4).*
- (1) Using key attached to container (or from another container), remove sealing strip.
  - (2) Remove top of can.
  - (3) Remove any padding from container.
  - (4) Remove contents.
- h. *Mine Canister Metal Container (fig. 3-5).*
- (1) Cut metallic seals with pliers and remove.
  - (2) Rotate cover and remove.
  - (3) Remove cushion.
  - (4) Untighten strap.
  - (5) Pull strap and remove contents.

**NOTE**

**Save all packing materials for future use, if needed, to repack mine canisters.**

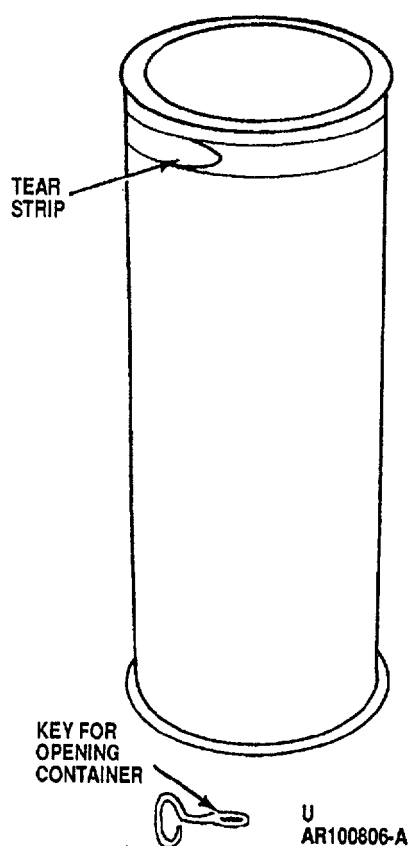

**Figure 3-4. Ammunition metal container.**

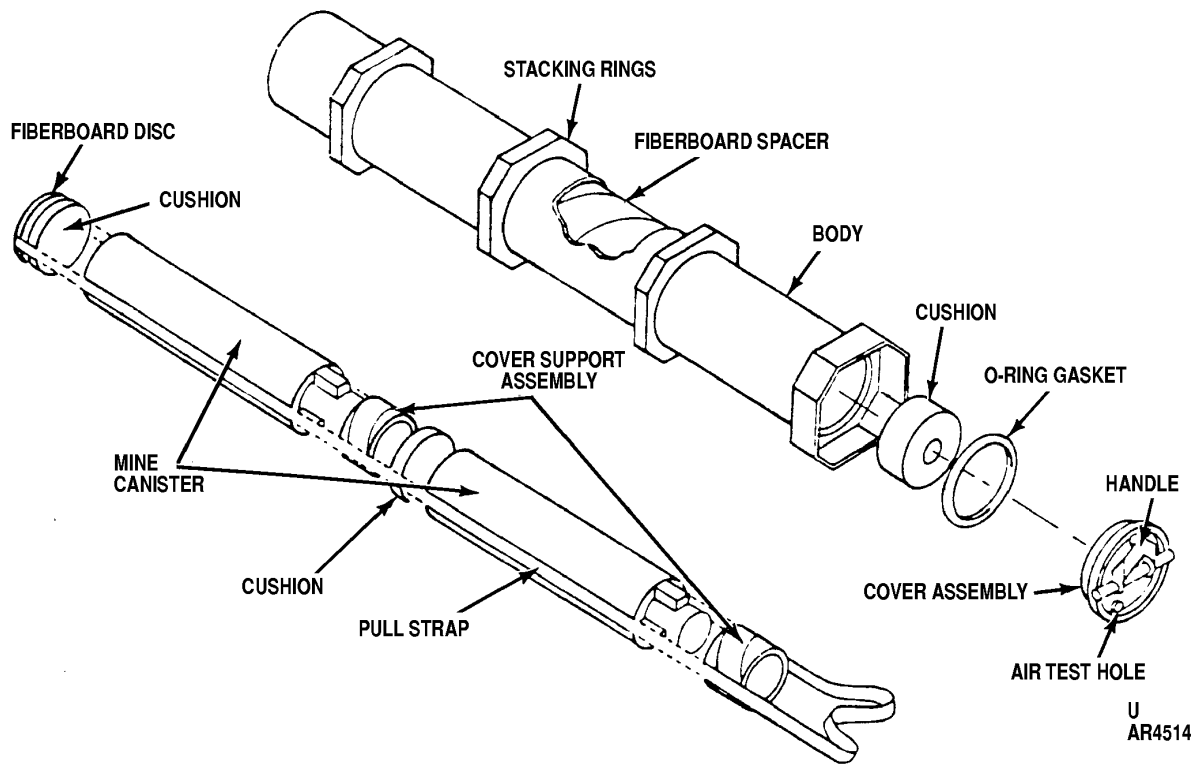

Figure 3-5. Mine canister metal container.

**SECTION II. TOOLS AND EQUIPMENT**

**3-3. Common Tools and Equipment**

Standard and commonly used tools and equipment having general application to this ammunition are authorized for issue by tables of organization and equipment (TOE).

**3-4. Repair Parts and Special Tools**

Repair parts and special tools required at organizational level are listed in Appendix B.

**SECTION III. MAINTENANCE**

**3-5. General**

Maintenance at the operator level consists mainly of preventive maintenance. Before deployment, inspect items for defects that may cause materiel not to function as designed.

**3-6. Inspection**

- a. Inspect mines, mine canisters, and relevant materiel for defects (table 3-1).
- b. Do not use defective items; turn in to authorized disposal personnel.

**NOTE**

Do Not attempt to remove rust or corrosion for M15 AT Mine secondary fuze wells. If corrosion is present in either secondary fuze well, return to the mine to the ASP as an unserviceable asset; explosive exudate may be present, treat accordingly.

- c. Lightly rusted or corroded items with metal components are serviceable and safe to use. Excessive rust or corrosion should be removed at organizational level if item is not to be used at once.

**Table 3-1. Defective Material - Operator Level**

Item	Defect
Mines	<ol style="list-style-type: none"> <li>1. Exuding</li> <li>2. Badly crushed, crumbled, dented, cracked, or broken body.</li> <li>3. Case rusted with penetration</li> <li>4. Water-soaked.</li> <li>5. Extreme corrosion</li> </ol>
Mine Canisters	<ol style="list-style-type: none"> <li>1. Deep dents; cracked, broken, or punctured tube wall.</li> <li>2. Body rusted with penetration.</li> <li>3. Water-soaked.</li> <li>4. Extreme corrosion.</li> <li>5. Broken selector.</li> </ol>

**3-6 Change 3**

**3-7. Cleaning/Preservation**

- a. Wipe clean items that have dirt, mud, grease, or sand. Use clean, dry cloth or other nonabrasive material.
- b. Wipe off light rust, which can be removed from metal components with clean, dry cloth.

**3-8. Adjustment of Firing Device and Fuze Safety Pin**

- a. Inspect for missing safety pins.
- b. Inspect safety pins for security.
- c. Adjust by spreading legs of cotter pin(s).

**3-9. Inspection of Mine Canisters**

- a. Check that arming slide is flush or below side of breech housing. This is the safe position for the slider.
- b. Check for mine canister identification for mission desired.
- c. Check that mine canister surface is free of foreign material.
- d. Check that the mine canister closure cap is on muzzle end of tube and that there are eight staked fastening locations.
- e. Check that the selector switch is not damaged or broken.

**CHAPTER 4  
UNIT MAINTENANCE INSTRUCTIONS**

**4-1. General**

a. Maintenance at the organizational level is performed by designated personnel in using units. Its purpose is to prevent further deterioration of ammunition which has been exposed to rough handling or adverse weather conditions. Direct support units may be called upon to provide technical assistance and packaging materials.

b. Responsibilities for maintenance are limited to those functions specified in Appendix C, Maintenance Allocation Chart (MAC). Only maintenance operations for which procedures are given in this manual or in the weapon operator's manual are authorized.

c. Maintenance shall be performed at least 90 feet from any ammunition magazine or storage shelter.

d. Remove ammunition from packaging before performing maintenance on packaging materials.

**4-2. Expendable Materials**

a. Paint, cleaning compounds, and other expendable materials authorized for use by organizational maintenance personnel are listed in Appendix D.

b. Expendable materials should be requisitioned through normal channels on an as required basis.

**4-3. Inspection of Packaging**

If receipt inspection or storage inspection of packaging reveals damage or deterioration to the extent that serviceability of the ammunition is questionable, unpack ammunition (using procedures in paragraphs 3-1 and 3-2) and visually inspect inner packs and/or items. Unpack only as far as necessary to determine serviceability.

a. *Packaging Defects.* Specific inspection criteria and identification of defects (as acceptable, repairable or irreparable) are outlined in table 4-1. The most commonly encountered packaging defects are listed below:

- (1) Outer containers (boxes) damaged, weathered, or rotted to the extent contents are not protected.
- (2) Inner container damaged to the extent contents are not protected or cannot be readily removed.
- (3) Container cap or closure insecure to the extent contents are not protected.
- (4) Inner containers wet (except metal), rusted, moldy, or mildewed.
- (5) Hardware or banding loose, missing, broken, or ineffective.
- (6) Handle or cleat missing or broken.
- (7) Contents loose to the extent item may be damaged in handling.

**Table 4-1. Inspection Criteria for Packaging**

Wooden boxes and crates

Component	Acceptable	Repairable	Irreparable at organizational level
Hardware	Operative and tight. Nails, screws and fasteners present and in good condition.	Inoperative or loose. Nails, screws and fasteners which can be replaced or properly sealed.	None None
Ends	Free from damage.	Broken or missing cleats and handles.	Damage which requires disassembly of box.
Wood	Splits less than 3-inches long no closer than 1 inch to edge of board or adjoining split. The board must be secured by at least one nail on each side of the split when it extends to the end of the board.	Splits over 3 inches but no closer than 1 inch to edge of board or adjoining split, or 1/8-inch wide, which can be repaired by use of corrugated fasteners.	Splits closer than 1 inch to edge of board or adjoining split or over 1/8-inch wide.



**Table 4-1. Inspection Criteria for Packaging - Continued**

Component	Acceptable	Reparable	Irreparable at organizational level
Strapping	Warping which does not prevent sealing of box or insertion of required ammunition.	None	Warping which prevents insertion or removal of rounds and/or sealing of the boxes.
	Light mold which can be brushed off. Mildew stains which do not effect legibility of markings.	None	Excessive mildew and mold which cannot be removed and which render markings illegible.
	Sound tight knots the diameter of which do not exceed 3/4 the width of the board.	None	Holes or loose knots which exceed 1-1/2 inches in largest diameter or 1/3 width of board.
	Skids securely attached to box - or crate. Knots no greater than 1/4 the width of skid.	Loose skids.	Knots greater than 1/4 the width of skid.
	Present and unweakened by rust or distortion.	Missing, rusted or distorted.	None

Wirebound boxes

Wirebound box	Slight scratches, non-penetrating dents.	Slight dry rot or fungus.	Completely crushed or broken. Badly dry rotted or fungus-covered inside and out. Insect infested. Warping that prevents reassembly.
Bound panels	Slight scratches, non-penetrating dents.	Small break or split in panel. Markings illegible. Surface damage leaving protruding splinters.	Panel broken in more than one place. Panel extensively worn punctured.
End panels	Intact and fully secured.	Slight rust. Staples missing.	One wire or more broken. Wire rusted through.

Fiber containers

Metal ends	Minor rust, cracks, indentions or splits which would not impair water proofing or serviceability of container.	None	Perforations, excessive rust, or ends which are crushed or not securely crimped to body.
Body and cap	No tears, cuts, or gouges.	Cuts, tears, or gouges not closer than 1 inch to closure less than 1/2 square inch in area and unpenetrated layers which can be spot painted.	Cuts, tears, or gouges closer than 1 inch to closure more than 1/2 square inch in area, or through all impregnated layers.
	No mold, mildew or rot.	None	Molded, mildewed or rotted.
	Free from wrinkles caused by looseness between layers.	None	Wrinkled or peeling.
	Blisters with combined area totaling less than 1/2 square inch.	None	Blisters with combined area of more than 1/2 square inch.
No moisture absorption.	None	Wet or soft containers.	

**Table 4-1. Inspection Criteria for Packaging - Continued**

Metal containers

Body	Dents less than 1/4 inch deep	Dents deeper than 1/4 inch which may be removed without weakening structure of container	Dents which impair the structural integrity of the material
	Tight seams which prevent entrance of moisture Free from rust	None	Loose or leaking seams
Cap and covers	Free from perforations.	Minor rust which can be removed	Rust which has caused pitting and perforations.
	Dents which do not prevent cover from closing.	None	Perforated
	Free from rust.	Dents which can be removed.	Dents which cannot be removed and/or prevent assembly to body
		Minor rust which can be removed.	Rust which has caused excessive pitting.

b. *Corrective Action.*

(1) Replace unserviceable containers using procedures in paragraph 4-9.

(2) Repair broken or damaged boxes using procedures in paragraph 4-7.

(3) Tighten or replace hardware or banding using procedures in paragraph 4-6.

**4-4. Inspection of Mines and Mine Canisters**

a. *Material Defects.* Specific defects (identified as acceptable, repairable or irreparable) and inspection criteria are outlined in Table 4-2 and Table 4-3. The most commonly encountered types of materiel defects are listed and illustrated below.

(1) Peeling, blistered, or scratched protective coatings on painted surfaces.

(2) Cracks, dents, and other obvious damage to components.

(3) Missing, illegible, incorrect, or misleading markings.

b. *Corrective Action.*

(1) Acceptable material to be repackaged using procedures in paragraph 4-9.

(2) Repairable items to be cleaned. Clean flaked or blistered coating and touch up paint and marking, following procedures in paragraph 4-5.

(3) Remark, following procedures in paragraph 4-5

c. *Disposition of Irreparable Items.* For disposition of irreparable ammunition, contact the next higher Maintenance level. Contact EOD personnel for disposition of mines considered to be hazardous.

**Table 4-2. Inspection Criteria for Mines and Fuzes**

Item	Acceptable	Repairable	Irreparable
Markings	Legible and correct	Illegible. Correct data available for remarking.	Correct data cannot be determined.
Paint or protective coat	No scratches, peeling, or blistering	Scratches, peeling, or blistering in spots.	Scratches peeling, or blistering requiring complete repaint.
Body	Free from rust.	Minor rust which can be removed with wire brush, sandpaper, or steel wool.	Extensive rust cannot be removed with wire brush, sandpaper, or steel wool.

**Table 4-2. Inspection Criteria for Mines and Fuzes - Continued**

Item	Acceptable	Reparable	Irreparable
Fuze well	Light corrosion on liner	Minor rust or corrosion which can be removed.  Light rust which can be removed	Beyond repair due to extensive corrosion and etching. Damaged threads. Heavy rust on threads
Markings	Correct and legible	Missing, illegible, incorrect or misleading, and correct data is available for remarking.	Correct data cannot be determined.
Body	Free from corrosion. Free from cracks Threads undamaged.	None. None. None.	Extensive corrosion. Cracks in metal parts. Threads damaged.
Safety pin and pull wire (when used)	Safety pins in position. Pull wire with light corrosion.	None. None.	Safety pins not in position. Pull wire broken or heavily corroded.
Body marking	Minor cuts, scratches, and dents. Legible and correct.	None.  Illegible, correct data available for remarking.	Severe cuts, tears, and dents.  Correct data cannot be determined. Cracked bodies.
Body	Free from corrosion.	None.	Corroded.
Secondary fuze wells	Free from corrosion.	None	Corrosion.

**Table 4-3. Inspection Criteria for Mine Canisters**

Marking	Legible and correct.	Illegible, correct data available for remarking.	Correct data cannot be determined.
Body	Free of rust  Dents less than 1/4 inch deep  No cracked, broken, or punctured metal parts.	Minor rust which can be removed with wire brush, sandpaper, or steel wool. None  None	Extensive rust cannot be removed with wire brush, sandpaper, or steel wool. Dents deeper than 1/3 inch. Cracked, broken, or punctured metal parts.
Closure cap	No missing screws or rivets.	None.	Missing screws or rivets.
Connector	Free of damage.	None.	Cannot mate with connector in launcher rack.
Arming Slider	Flush or below side of breech housing.	None.	Not flush or above side of breech housing.
Selector Switch	Broken.	None.	Cannot include faults simulation.

**4-5. Cleaning, Touch-Up, and Marking of Mines and Mine Canisters**

a. *Cleaning.*

**NOTE**

Rags will be stored in noncombustible self-closing containers. Wastes or used rags will be placed in water-filled containers. Areas will be well ventilated where solvents and paints are used.

**WARNING**

**PRIMERS (FOR MINE FUZE) WILL BE CLEANED ONLY WITH RAGS DAMPENED WITH ALCOHOL OR ACETONE.**

(1) Remove dirt, mud, and other foreign material using rags or brushes. Use rags dampened with alcohol or acetone to remove grease.

(2) Using nonferrous brush, remove flaked, chipped, blistered, or peeling paint.

(3) Remove rust using nonferrous brush or sandpaper.

**NOTE**

**Clean fuze well and threads with small stainless steel brush and rags dampened with alcohol.**

(4) Inspect cleaned item for cracks or other damage or deterioration.

(5) Allow solvent-cleaned surfaces to dry thoroughly before painting.

b. *Touch-up.*

(1) Use masking tape to cover existing markings which are in good condition and parts, such as fuze threads, etc., which should not be painted.

(2) Using a spray can or brush, cover bare metal with primer and allow to dry.

(3) Using a spray can or brush, paint primed area with two coats, allowing first coat to dry before applying second.

(4) After paint has dried, remove masking tape.

c. *Remarking.*

(1) Observe markings on a like item for correct positioning of data.

(2) Using a felt marker or small brush and paint, restore any illegible or missing markings. (See tabulated data in Chapter 1 for color identification.) (3) Allow markings to dry before handling or repacking.

**4-6. Maintenance of Packaging Hardware**

a. *Repair of Damaged Hardware.* Hardware which has been damaged to the point that it is inoperable is usually irreparable; however, minor damage can usually be corrected by straightening, as follows: (1) Using pliers, carefully bend damaged item until its configuration is the same as the serviceable item.

(2) Test repaired hardware for proper functioning.

b. *Replacement of Irreparable Hardware.*

Hardware which cannot be repaired can be replaced with a serviceable item cannibalized from an unserviceable container, as follows:

(1) Using a screwdriver, remove unserviceable hardware.

(2) Attempt to reinstall serviceable hardware in existing holes. Secure with screws.

(3) If screws are missing or cannot be tightened in existing holes, proceed as follows: (a) Replace missing screws with others obtained from an unserviceable box.

(b) If screws cannot be tightened, move hardware (with box top in place) to a different location where screws can be secured. If necessary, carve notch to accommodate hinge pin.

(c) Mark location for attaching screws and remove hardware.

(d) Drive and remove a small nail at each location to provide a pilot hole.

(e) Place hardware and screws in position and secure.

c. *Replacing Broken, Loose, or Deteriorated Strapping.*

(1) Cut pieces of 5/8-inch banding of sufficient length to go around box plus about 6 to 8 inches.

(2) Position strap(s) under box.

- (3) Insert one strap end into strap stretcher so that strap is held firmly by stretcher, with about 3 inches of strap protruding.
- (4) Place clip over strap end.
- (5) Thread loose end of strap through clip and into stretcher head.
- (6) Tighten strap by repeated movement of ratchet lever until edges begin to cut into box.
- (7) Using banding crimper, crimp clip in two places.
- (8) Release locking pawl on stretcher and slide stretcher out.
- (9) Cut off excess strapping.
- (10) Repeat (3) through (9), above, for each strap.

#### 4-7. Maintenance of Packaging Containers and Materials

a. *Cleaning of Wood and Wirebound Boxes.* Using rags, soap and water, wire brush, or sandpaper, as necessary, remove mud, dirt, or foreign material such as slightly dry rot, mildew, or fungus.

b. *Repair of Cracks and Splits in Wood.*

- (1) Hold board tight so that the crack or split is closed.
- (2) Hammer corrugated fasteners into wood at 4 to 6-inch intervals. Fasteners should be centered across crack.

c. *Repair of Wirebound Panels.* The normal method of repair for wirebound boxes is replacement of the damaged section or the whole box with a good section or box from expended ammunition. Always assure that the correct markings, including lot number of the items within it, are on the replacement box. If no replacement section or box is available, minor repairs may be made to damaged panels to restore the box to a serviceable state.

(1) Splinters should be scraped off and the area smoothed with a pocket knife and sandpaper, if necessary.

(2) Cracked or penetrated panels may be reinforced by nailing a similar or smaller sized panel from a scrap box over the damaged one. Nail from the inside and hammer over the nail points.

(3) Broken wires may be spliced with available scrap wire. Twist the splice wire together with the broken ends for at least 6 inches on each side of the break and hammer the wires flat against the panel(s).

d. *Repair of Broken Cleats, Battens, or Wood Handles.*

- (1) Remove broken cleat with claw hammer or pry bar.
- (2) Remove serviceable cleat with claw hammer or pry bar from an otherwise unserviceable box.
- (3) Position serviceable cleat in box and secure with three to five small nails.
- (4) Bend nails over inside of box with hammer.

e. *Repair of Rope or Strap Handles.*

- (1) Remove cleats holding handle with claw hammer or pry bar.
- (2) Remove serviceable handle from an otherwise unserviceable box by removing the holding cleats with claw hammer or pry bar.

#### NOTE

**Do not remove nails or staples attaching handles to cleats.**

- (3) Position serviceable handle and cleats and attach to box with three to five nails in each cleat.
- (4) Bend nails over inside of box with hammer.

f. *Painting of Wood Boxes.* Normally, used boxes will not be painted except to obliterate previous markings or to indicate less than full pack (paragraph 4-10).

**4-8. Marking of Packaging Material**

a. *Markings on Outer Box.* The following information must be legible on each box:

Title	Example
Nomenclature	MINE, APERS, M16: W/COMBINATION FUZE M605
National Stock Number (Including DODIC)	1345-00-028-5131 K092
Lot Number	IOP 7-7
Date of Manufacture	12-55
Quantity	4 (Usually precedes nomenclature)

**NOTE**

Ends of box will have DODIC and Lot Number.

b. *Markings on Inner Container.* The following information must be legible on each inner container:

Title	Example
Nomenclature	MINE, APERS, M16: W/COMBINATION FUZE M605
DODIC	K092
Lot Number	IOP 7-7
Quantity	1

c. *Restoration of Markings.*

- (1) Carefully observe information and location of markings on packaging of like item.
- (2) Using waterproof ink marker, china marking pencil, or small brush and paint, restore markings which are faded, obliterated during cleaning, or painted over.
- (3) Check markings for accuracy and allow to dry.
- (4) Repack mines following procedures in paragraph 4-9.

**4-9. Repacking Procedures**

**NOTE**

Packing Materials, Accessories, and Tools, Appendix B, reflect most recent packaging. See Appendix E for packing and marking data.

a. *General.*

- (1) Always repack mines in serviceable packaging containers.
- (2) Select packaging components from those for similar mine items.
- (3) Use filler pads, as required, for a tight pack.
- (4) Remark package, as necessary, to assure proper markings (paragraph 4-8).

b. *Metal Container.*

- (1) Place item in container so that it is firmly seated in filler materials.
- (2) Cover any sensitive parts, such as primers, with padding.
- (3) Place top on container.
- (4) Seal with plastic filament tape or black nylon tape by wrapping joint in a double layer and folding edges over top.

c. *Vapor Barrier Bag.*

- (1) Place protective materials around sensitive parts (primer, etc.) of item.
- (2) Place the item(s) into paperboard box.
- (3) Close paperboard box and seal with tape.
- (4) Insert box in barrier bag.
- (5) Exhaust air from bag, fold edges over, and seal with tape.

d. *Wood Box With Hasp and Hinge.*

- (1) Place inner pack(s) in box. Position items to balance load for carrying.
- (2) Use filler material or empty inner containers when box is not full. Place padding on top of items.
- (3) Close box top.
- (4) Close hasp.
- (5) Rotate hasp catch to latch position.

e. *Wirebound Box.*

- (1) Position inner pack(s) on bottom of box. Position items to balance load for carrying.

- (2) Place box ends in position with enough filler material to make a tight pack.
- (3) Raise box front into position and hold.
- (4) Raise box back into position and hold.
- (5) Close top, being careful to fit wire loops on top over wire loops on front.
- (6) Bend wire loops flat against box using a sallee closer (fig. 3-2).

f. *Pallet.*

- (1) Arrange boxes, etc., on pallet in the same configuration as the original load, if possible. For M15 AT Mines orient boxes on their sides to prevent water from collecting in the bottom secondary fuze well. Distribute load for balance.
- (2) Place separators between rows.
- (3) Place top in position.
- (4) Cut 1-1/4 inch banding pieces about 2 feet longer than pallet girth.
- (5) Position straps under part of pallet bottom.
- (6) Position wood strips under straps to protect ammunition packaging.
- (7) Insert one strap end from rear into strap stretcher so that strap is held firmly by stretcher and about 4 to 6 inches of strap protrudes.
- (8) Place clip over strap end.
- (9) Thread loose end of that strap through clip and into stretcher head.
- (10) Tighten strap by repeated movement of ratches lever until edges begin to cut into wood.

- (11) Using banding crimper, crimp clip in two places.
- (12) Release locking pawl on stretcher and slide stretcher out.
- (13) Cut off excess strapping.
- (14) Repeat steps (7) through (13), above, for each strap.

#### 4-10. **Painting and Marking of Boxes with Light Loads**

##### **NOTE**

Organizations will apply this procedure only when boxes with less than full contents are to be returned to storage area or transported to new location. When painting of boxes is required, remarking (except quantity) may be avoided by applying masking tape in markings prior to painting.

Boxes with less than full contents will be painted orange, as follows:

- a. Check contents with markings on box to verify that nomenclature and lot number are correct.
- b. Make diagram of markings on box and record all markings except quantity figure.
- c. Apply orange enamel to all outer surfaces of box. If enamel is not available, use orange lacquer.
- d. When box is dry, remark box with correct markings (paragraph *b*, above).
- e. Count quantity of items in box and mark number on box in the same position as the original quantity figure.
- f. Mark the words "BOX" on each side of box, using approximately the same letters as original markings.

## CHAPTER 5 SHIPMENT/MOVEMENT AND STORAGE

---

### Section I. SHIPMENT/MOVEMENT

#### 5-1. Precautions

- a. Provide adequate protection for land mines during transportation.
- b. Assure that mines will not be damaged, contaminated or otherwise degraded so that their usefulness becomes impaired or that they become dangerous.

#### 5-2. Instructions

- a. *Transportation.*

#### NOTE

Blocking and bracing must be adequate to withstand sudden stops and starts, as well as off-road operation.

- (1) Block and brace packages being transported in trucks, jeeps, and other tactical vehicles.
- (2) If packing is broken or damaged but munitions remain serviceable, restore or replace packing by using acceptable packing material. Assure that all markings (e.g., lot number, nomenclature, NSN, etc.) are transferred to new packing.

- b. *Handling.*

#### WARNING

**AVOID IMPROPER HANDLING - IT MAY PROVE HAZARDOUS TO PERSONNEL AND IMPAIR RELIABILITY AND SAFETY OF MATERIALS.**

- (1) Retain materials in their packing until issued.
- (2) Do not roll, drop, throw, or subject boxes to rough handling.

#### 5-3. Data

The following information appears on the outer pack:

- a. Department of Transportation (DOT) shipping class and designation.
- b. National Stock Number (NSN) and Department of Defense Identification Code (DODIC).
- c. Ammunition lot number.
- d. Gross weight of packing container and contents.
- e. Cubical displacement of packing container.
- f. Date manufactured.
- g. Descriptive nomenclature of packed item.
- h. Storage temperature limit (if nonstandard).

### Section II. STORAGE

#### 5-4. Precautions

- a. Select level, well drained sites free from readily ignitable and flammable materials.
- b. Provide nonflammable or fire-resistant overhead covers (e.g. tarpaulin) for all items. Maintain overhead covers

between cover and items. Keep cover at least 6 inches from pile on ends and at sides to permit circulation of air.

- c. Temporarily store unserviceable items in segregated area for inspection and repacking.



**5-5. Data**

*a. Field Storage Compatibility Groups.*

(1) *General.* Storage compatibility groups are the primary groupings for segregating ammunition for storage in the field. Safety procedures covering storage are based on the following factors: Normally only one kind of material is stored in a stack. Always keep initiating devices separated from other high explosives. Arrange items in stacks so as to facilitate inventory and inspection.

**NOTE**

Where camouflage is a consideration, stacks may be stepped-in toward top (terraced or pyr-

amid stacking) to decrease shadows. Whenever desirable, components of complete rounds may be stored within the same FSU.

(2) *Field storage category for explosive materials.* Explosives and components, such as blasting caps, firing devices, and safety fuzes are included in category E of field storage categories.

*b. Quantity-Distance for Field Storage Categories.* Procedures specified in table 5-1 are to be used for guidance in field storage of military explosives. It must be emphasized that any reduction of distances or increase in tonnages will increase the probability of loss of life and ammunition (see also AR 385-64 and DA Pam 385-64).

Table 5-1. Quantity-Distance Data for Field Storage Category E.

			Minimum distance in feet between		
	Gross tons per FSU	Stacks unbarricaded	Stacks barricaded	FSU unbarricaded	Categories
Less than 5	50	75	60	300	900
5-10 maximum	50	105	75	300	900

*c. Permanent Installation Storage.* For permanent storage, standard quantity-distance classes and storage compatibility groups given in AR 385-64 and DA Pam 385-64.

**5-6. Procedures**

*a.* When stacking, use heavy, well supported dunnage to prevent stack from sinking, and to keep bottom tier off ground.

*b.* Use hardstand of gravel and sand rather than excessive dunnage.

*c.* Allow at least 6-inch clearance beneath pile for air circulation.

*d.* Dig suitable trenches around stacking area to prevent water from flowing under pile.

## APPENDIX A REFERENCES

### A.1 SCOPE.

This appendix lists all Army regulations, field manuals, forms, pamphlets, and technical manuals referenced in this manual. The publication index (DA Pam 25-30) should be consulted frequently for latest changes or revisions of references given in this appendix and for new publications relating to the material covered in this manual.

### A.2 ARMY REGULATIONS.

Malfunctions Involving Ammunition and Explosives .....	AR 75-1
Accident Reporting and Records.....	AR 385-40
Range Safety .....	AR 385-63
U.S. Army Explosives Safety Program.....	AR 385-64

### A.3 FIELD MANUALS.

Ammunition Handbook: Tactics, Techniques, and Procedures for Munition Handlers.....	FM 4-30.13
Explosives and Demolitions.....	FM 5-250
Mine/Countermine Operations at the Company Level .....	FM 20-32

### A.4 FORMS.

U.S. Army Accident Report.....	DA Form 285
Recommended Changes to Publications and Blank Forms.....	DA Form 2028

### A.5 PAMPHLETS.

Consolidated Index of Army Publications and Blank Forms.....	DA Pam 25-30
Ammunition and Explosive Safety Standard .....	DA Pam 385-64
The Army Maintenance Management System (TAMMS) Users Manual.....	DA Pam 750-8

### A.6 TECHNICAL MANUALS .

Operator's Manual for Dispenser, Mine: M139 (NSN 1095-01-235-3139) (EIC: 3V8) for Ground Volcano for 5-Ton Mounting Kit (1095-01-252-2818) (EIC: 3V9), M548A1 Mounting Kit (1095-01-331-6755) (EIC: 3WD) and Palletized Mounting Kit (1095-01-492-4259).....	TM 9-1095-208-10-1
Ammunition, General.....	TM 9-1300-200
Ammunition, Maintenance.....	TM 9-1300-250

A.6 TECHNICAL MANUALS - Continued.

Direct Support and General Support Maintenance Manual for Land Mines .....	TM 9-1345-203-34
Use of Mine, Antitank: HE, Heavy M15 as Substitute for Charge Assembly, Demolition: M37 or M183 .....	TM 9-1375-200/2
Destruction of Conventional Ammunition and Improved Conventional Munitions (ICM) to Prevent Enemy Use .....	TM 43-0002-33

**APPENDIX B  
PACKING MATERIALS, ACCESSORIES, AND TOOLS**

**Section I. INTRODUCTION**

**B-1. Scope**

This appendix lists packing materials, accessories, and tools required for the performance of unit maintenance of land mines.

**B-2. General**

This appendix is divided into the following sections:

*a. Section II - Packing Materials and Accessories.* A list of packing materials and accessories authorized for the performance of maintenance at the unit level.

*b. Section III- Special Packing Tools.* A list of special packing tools and equipment authorized for the performance of maintenance at the unit level.

**B-3. Explanation of Columns**

The following provides an explanation of columns in Section II and III.

*a. Part Number.* Indicates the primary number used by the manufacturer which controls the design and characteristics of the item. Drawings can be obtained from originating source (see CAGE Code).

*b. Contractor and Government Entity Code (CAGE) - (Formerly known as Federal Supply Code for Manufacturers (FSCM)).* A five-digit code used to identify the manufacturer, distributor, or Government agency/activity that supplies the item.

*c. Figure Number.* This column lists the number of the figure where the item is identified/located.

*d. Description.* Indicates the Federal item name and any additional description of the item required.

**Section II. PACKING MATERIALS, AND ACCESSORIES**

Part No. (Dwg No.)	CAGE Code	Figure No.	Description
8861849	19203		BOX, AMMUNITION: for Mine, APERS, M14 and components.
7548171	19203		BOX, AMMUNITION: for Mine, AT, Heavy Practice M20.
7548396	19203		BOX, PACKING, AMMUNITION: for Mine, Heavy Practice M12A1 and components
8822122	19203		BOX, PACKING, AMMUNITION: for Mine, APERS, M26
7548392	19203	2-19	BOX, PACKING, ASSEMBLY: for Mine, AT, M15 and components.
7548179	19203		BOX, PACKING, AMMUNITION: for Mine, APERS, M16 series and components.

Part No. (Dwg No.)	CAGE Code	Figure No.	Description
8800900	19203		BOX, PACKING, AMMUNITION: for Mine, APERS, M18A1 w/ accessories.
8830877	19203		BOX, PACKING, AMMUNITION: for Mine, AT, M19 and components.
8830860	19203	2-54	BOX, PACKING, AMMUNITION: for Mine, AT, M21 and components.
8880988	19203		BOX, PACKING, AMMUNITION: for Mine AT, M24 and components.
8845546	19200	2-14	BOX, PACKING, AMMUNITION: for Mine, APERS, M86.
8800900	19203		BOX, PACKING, AMMUNITION: for Mine, APERS, Practice M68 with accessories.
7548180	19203	2-18	BOX, PACKING, ASSEMBLY: Mine, APERS, Practice M8/M8A1 and components.
8865541	19200	2-13	CONTAINER, SHIPPING AND STORAGE: PA19, Mine, APERS, M86.
9390404	19200		CONTAINER, AMMUNITION: PA113 for M87, M88, and M89.
12630920-1	19200		COVER ASSEMBLY, SUPPORT:
12630920-2	19200		COVER ASSEMBLY, SUPPORT:
12561553	19200		CUSHIONING MATERIAL, PACKAGING:
12630932	19200		CUSHIONING MATERIAL, PACKAGING:
MIL-P-15011	81349		PALLET, MATERIAL HANDLING: 40 in. X 48 in. for Mines, AP, M14, M16, M18, AT, M15, and M19.
937178	19200		RETAINER, PACKING:
8794342-6	19200		SEAL, ANTIPIRFERAGE:
12561555	19200		SPACER, SLEEVE:
12630919	19200		WEBBER, TEXTILE:

## Section III. SPECIAL PACKING TOOLS

Part No. (Dwg No.)	CAGE Code	Figure No.	Description
8864731	19203		SALLEE CLOSER: (5120-00-319-5434)
GGG-S-291	70786		SHEARS, METAL CUTTING, HAND: 2 1/2-in. (5100-00-293-0089)
MIL-S-43104	81349		STRAPPING AND SEALING KIT: 1-1/4 in. Strapping Type V (3540-00-565-6244)
MIL-S-43104	80244		STRAPPING AND SEALING KIT: 5/8 in. Strapping Type III. (3540-00-565-6242)

**THIS PAGE INTENTIONALLY LEFT BLANK**  
**B-4**

# APPENDIX C

## MAINTENANCE ALLOCATION CHART (MAC)

### Section I. INTRODUCTION

#### C.1 THE ARMY MAINTENANCE SYSTEM MAC.

C.1.1 This introduction provides a general explanation of all maintenance and repair functions authorized at the two maintenance levels under the Two-Level Maintenance System concept.

C.1.2 The MAC designates overall authority and responsibility for the performance of maintenance functions on the identified end item or component. The application of the maintenance functions to the end item or component shall be consistent with the capacities and capabilities of the designated maintenance levels, which are shown on the MAC in column (4) as:

- Field - Includes three subcolumns, Crew (C), Service (O) and Field (F) maintenance.
- Sustainment - Includes two subcolumns, Below Depot (H) and Depot (D) maintenance.

C.1.3 The tools and test equipment requirements (immediately following the MAC) list the tools and test equipment (both special tools and common tool sets) required for each maintenance function as referenced from the MAC.

C.1.4 The remarks (immediately following the tools and test equipment requirements) contain supplemental instructions and explanatory notes for a particular maintenance function.

#### C.2 MAINTENANCE FUNCTIONS.

Maintenance functions are limited to and defined as follows:

C.2.1 Inspect. To determine the serviceability of an item by comparing its physical, mechanical, and/or electrical characteristics with established standards through examination (e.g., by sight, sound, or feel). This includes scheduled inspection and gagings and evaluation of cannon tubes.

C.2.2 Test. To verify serviceability by measuring the mechanical, pneumatic, hydraulic, or electrical characteristics of an item and comparing those characteristics with prescribed standards on a scheduled basis, i.e., load testing of lift devices and hydrostatic testing of pressure hoses.

C.2.3 Service. Operations required periodically to keep an item in proper operating condition; e.g., to clean (includes decontaminate, when required), to preserve, to drain, to paint, or to replenish fuel, lubricants, chemical fluids, or gases. This includes scheduled exercising and purging of recoil mechanisms.

C.2.4 Adjust. To maintain or regulate, within prescribed limits, by bringing into proper position, or by setting the operating characteristics to specified parameters.

C.2.5 Align. To adjust specified variable elements of an item to bring about optimum or desired performance.

C.2.6 Calibrate. To determine and cause corrections to be made or to be adjusted on instruments of test, measuring, and diagnostic equipment used in precision measurement. Consists of comparisons of two instruments, one of which is a certified standard of known accuracy, to detect and adjust any discrepancy in the accuracy of the instrument being compared.

C.2.7 Remove/Install. To remove and install the same item when required to perform service or other maintenance functions. Install may be the act of emplacing, seating, or fixing into position a spare, repair part, or module (component or assembly) in a manner to allow the proper functioning of an equipment or system.

C.2.8 Replace. To remove an unserviceable item and install a serviceable counterpart in its place. "Replace" is authorized by the MAC and assigned maintenance level is shown as the third position code of the Source, Maintenance and Recoverability (SMR) code.

C.2.9 Repair. The application of maintenance services, including fault location/troubleshooting, removal/installation, disassembly/assembly procedures, and maintenance actions to identify troubles and restore serviceability to an item by correcting specific damage, fault, malfunction, or failure in a part, subassembly, module (component or assembly), end item, or system.



**NOTE**

The following definitions are applicable to the “repair” maintenance function:

Services - Inspect, test, service, adjust, align, calibrate, and/or replace.

Fault location/troubleshooting - The process of investigating and detecting the cause of equipment malfunctioning; the act of isolating a fault within a system or Unit Under Test (UUT).

Disassembly/assembly - The step-by-step breakdown (taking apart) of a spare/functional group coded item to the level of its least component, that is assigned as SMR code for the level of maintenance under consideration (i.e., identified as maintenance significant).

Actions - Welding, grinding, riveting, straightening, facing, machining, and/or resurfacing.

**C.2.10 Overhaul.** That maintenance effort (service/action) prescribed to restore an item to a completely serviceable/operational condition as required by maintenance standards in appropriate technical publications. Overhaul is normally the highest degree of maintenance performed by the Army. Overhaul does not normally return an item to like new condition.

**C.2.11 Rebuild.** Consists of those services/actions necessary for the restoration of unserviceable equipment to a like new condition in accordance with original manufacturing standards. Rebuild is the highest degree of materiel maintenance applied to Army equipment. The rebuild operation includes the act of returning to zero those age measurements (e.g., hours/miles) considered in classifying Army equipment/components.

**C.3 EXPLANATION OF COLUMNS IN THE MAC.**

**C.3.1 Column (1) - Group Number.** Column (1) lists Functional Group Code (FGC) numbers, the purpose of which is to identify maintenance significant components, assemblies, subassemblies, and modules with the Next Higher Assembly (NHA).

**C.3.2 Column (2) - Component/Assembly.** Column (2) contains the item names of components, assemblies, subassemblies, and modules for which maintenance is authorized.

**C.3.3 Column (3) - Maintenance Function.** Column (3) lists the functions to be performed on the item listed in column (2). (For a detailed explanation of these functions refer to “Maintenance Functions” outlined above.)

**C.3.4 Column (4) - Maintenance Level.** Column (4) specifies each level of maintenance authorized to perform each function listed in column (3), by indicating work time required (expressed as manhours in whole hours or decimals) in the appropriate subcolumn. This work time figure represents the active time required to perform that maintenance function at the indicated level of maintenance. If the number or complexity of the tasks within the listed maintenance function varies at different maintenance levels, appropriate work time figures are to be shown for each level. The work time figure represents the average time required to restore an item (assembly, subassembly, component, module, end item, or system) to a serviceable condition under typical field operating conditions. This time includes preparation time (including any necessary disassembly/assembly time), troubleshooting/fault location time, and quality assurance time in addition to the time required to perform the specific tasks identified for the maintenance functions authorized in the MAC. The symbol designations for the various maintenance levels are as follows:

Field:

- C - Crew maintenance
- O - Service maintenance
- F - Field maintenance

Sustainment:

- L - Specialized Repair Activity (SRA)
- H - Below depot maintenance
- D - Depot maintenance

**NOTE**

The “L” maintenance level is not included in column (4) of the MAC. Functions to this level of maintenance are identified by a work time figure in the “H” column of column (4), and an associated reference code is used in column (6), Remarks Code. This code is keyed to the remarks and the SRA complete repair application is explained there.

**C.3.5 Column (5) - Tools and Equipment Reference Code.** Column (5) specifies, by code, those common tool sets (not individual tools), common Test, Measurement and Diagnostic Equipment (TMDE), and special tools, special TMDE and special support equipment required to perform the designated function. Codes are keyed to the entries in the tools and test equipment table.

C.3.6 Column (6) - Remarks Code. When applicable, this column contains a letter code, in alphabetical order, which is keyed to the remarks table entries.

**C.4 EXPLANATION OF COLUMNS IN THE TOOLS AND TEST EQUIPMENT REQUIREMENTS.**

C.4.1 Tool or Test Equipment Reference Code. The tool or test equipment reference code correlates with a code used in column (5) of the MAC.

C.4.2 Maintenance Level. The lowest level of maintenance authorized to use the tool or test equipment.

C.4.3 Nomenclature. Name or identification of the tool or test equipment.

C.4.4 National Stock Number. The NSN of the tool or test equipment.

C.4.5 Tool Number. The manufacturer's part number, model number, or type number.

**C.5 EXPLANATION OF COLUMNS IN THE REMARKS.**

C.5.1 Remarks Code. The code recorded in column (6) of the MAC.

C.5.2 Remarks. This column lists information pertinent to the maintenance function being performed as indicated in the MAC.

## Section II. MAINTENANCE ALLOCATION CHART FOR LAND MINES

**Maintenance Allocation Chart for Land Mines**

(1)  Group Number	(2)  Component/Assembly	(3)  Maintenance Function	(4) Maintenance Level					(5)  Tools and Equipment Ref Code	(6)  Remarks Code
			Field			Sustainment			
			Crew	Service	Field	Below Depot	Depot		
			C	O	F	H	D		
0100	Mines, Antipersonnel Service	Inspect	X						
0101	a. Mines, APERS: M14	Test					X		
		Unpack	X						
		Repack	X						
		Clean	X						
	b. Detonator M46	Inspect	X						
		Test					X		
		Unpack	X						
		Repack	X						
		Clean	X						

Maintenance Allocation Chart for Land Mines - Continued

(1) Group Number	(2) Component/Assembly	(3) Maintenance Function	(4) Maintenance Level					(5) Tools and Equipment Ref Code	(6) Remarks Code
			Field			Sustainment			
			Crew	Service	Field	Below Depot	Depot		
			C	O	F	H	D		
0102	c. Wrench M22	Inspect	X						
		Unpack	X						
		Repack	X						
		Clean	X						
		Install	X						
	d. Packing Material	Inspect		X					
		Clean		X					
		Mark		X					
		Repair		X					
	a. Mine, APERS, M16 Series	Inspect	X						
		Test					X		
		Unpack	X						
		Repack	X						
		Clean	X						
		Touchup		X					
		Mark			X				
		Paint			X				
		b. Fuze, Mine Comb, M605	Inspect	X					
			Test			X			
	Unpack		X						
	Repack		X						
	Clean		X						
	Touchup			X					
	Mark				X				
	c. Spool wire	Inspect	X						
		Test			X				
		Unpack	X						
		Repack	X						
Clean		X							
d. Wrench M25	Install	X							
	Repack	X							
	Clean	X							

Maintenance Allocation Chart for Land Mines - Continued

(1) Group Number	(2) Component/Assembly	(3) Maintenance Function	(4) Maintenance Level					(5) Tools and Equipment Ref Code	(6) Remarks Code
			Field			Sustainment			
			Crew	Service	Field	Below Depot	Depot		
			C	O	F	H	D		
0103	e. Packing Material	Inspect		X					
		Touchup		X					
		Install		X					
		Repair			X				
		Replace			X				
	a. Mine, APERS: M18A1	Inspect	X						
		Test					X		
		Unpack	X						
		Repack	X						
	b. Bandoleer M7	Clean	X						
		Inspect	X						
		Unpack	X						
		Repack	X						
	c. Test Set M40	Clean	X						
		Inspect	X						
		Test	X						
		Unpack	X						
	d. Firing Device M57	Repack	X						
		Clean	X						
		Inspect	X						
		Test	X						
	e. Adapter	Unpack	X						
		Repack	X						
		Clean	X						
		Install	X						
	f. Blasting Cap Assy M4	Inspect	X						
		Test	X						
		Unpack	X						
Repack		X							
Clean		X							
		Install	X						

Maintenance Allocation Chart for Land Mines - Continued

(1) Group Number	(2) Component/Assembly	(3) Maintenance Function	(4) Maintenance Level					(5) Tools and Equipment Ref Code	(6) Remarks Code
			Field			Sustainment			
			Crew	Service	Field	Below Depot	Depot		
			C	O	F	H	D		
1040	g. Packing Material	Inspect		X					
		Clean		X					
		Mark		X					
		Repair		X					
		Replace		X					
	a. Mine, APERS: M26	Inspect	X						
		Test					X		
		Unpack	X						
		Repack	X						
		Clean	X						
010401	b. Packing Material	Inspect	X						
		Inspect		X					
		Clean		X					
		Mark		X					
		Repair		X					
	a. Mine, APERS: M86	Replace		X					
		Inspect	X						
		Test					X		
		Unpack	X						
		Repack	X						
b. Bandoleer	Clean	X							
	Inspect	X							
	Unpack	X							
	Repack	X							
	Clean	X							
c. Packing Material	Inspect		X						
	Clean		X						
	Touchup		X						
	Mark			X					
	Paint			X					
	Repair		X						
	Replace		X						

Maintenance Allocation Chart for Land Mines - Continued

(1) Group Number	(2) Component/Assembly	(3) Maintenance Function	(4) Maintenance Level					(5) Tools and Equipment Ref Code	(6) Remarks Code
			Field			Sustainment			
			Crew C	Service O	Field F	Below Depot H	Depot D		
0200	Mines, Antipersonnel, Practice	Inspect	X						
0201	a. Mine, APERS, Practice: M8 Series	Test					X		
		Unpack	X						
		Repack	X						
		Clean	X						
		Touchup		X					
		Mark			X				
		Paint			X				
		Repair		X					
	b. Mine Cap	Inspect	X						
		Unpack	X						
		Repack	X						
		Clean	X						
		Install	X						
		Replace	X						
	c. Simulator (Projectile)	Inspect	X						
		Test					X		
		Unpack	X						
		Repack	X						
		Clean	X						
		Install	X						
		Replace	X						
	d. Spotting Charge	Inspect	X						
		Test					X		
		Unpack	X						
		Repack	X						
		Clean	X						
		Install	X						
		Replace	X						

Maintenance Allocation Chart for Land Mines - Continued

(1) Group Number	(2) Component/Assembly	(3) Maintenance Function	(4) Maintenance Level					(5) Tools and Equipment Ref Code	(6) Remarks Code
			Field			Sustainment			
			Crew	Service	Field	Below Depot	Depot		
			C	O	F	H	D		
0202	e. Fuze, Mine, Combo, Prac: M10A1	Inspect	X						
		Test					X		
		Unpack	X						
		Repack	X						
		Clean	X						
		Touchup		X					
		Mark			X				
		Paint			X				
		Repair		X					
	Replace	X							
	f. Igniter Assembly	Inspect	X						
		Test					X		
		Unpack	X						
		Repack	X						
		Clean	X						
		Install	X						
		Replace	X						
	g. Spool Assembly	Inspect	X						
		Unpack	X						
		Repack	X						
		Clean	X						
		Install	X						
	h. Packing Material	Inspect			X				
		Clean			X				
		Mark			X				
		Repair			X				
		Replace			X				
	a. Mine, APERS, Prac: M35	Inspect	X						
Test		X							
Unpack		X							
Repack		X							
Clean		X							
Touchup			X						
Mark			X						
Install		X							
Paint				X					

Maintenance Allocation Chart for Land Mines - Continued

(1) Group Number	(2) Component/Assembly	(3) Maintenance Function	(4) Maintenance Level					(5) Tools and Equipment Ref Code	(6) Remarks Code
			Field			Sustainment			
			Crew	Service	Field	Below Depot	Depot		
			C	O	F	H	D		
0203	b. Dye Capsule	Inspect	X						
		Test	X						
		Unpack	X						
		Repack	X						
		Clean	X						
		Install	X						
		Replace	X						
	c. Simulator and Barrel Assy	Inspect	X						
		Unpack	X						
		Repack	X						
		Clean	X						
		Install	X						
		Replace	X						
		d. Cartridge Case and Sleeve Assy	Inspect	X					
	Test						X		
	Unpack		X						
	Repack		X						
	Clean		X						
	Install		X						
	Replace		X						
	e. Spring Housing Retainer	Inspect	X						
		Unpack	X						
		Repack	X						
		Clean	X						
		Install	X						
		Replace	X						
		a. Mine, APERS, Prac: M68	Inspect	X					
Test	X								
Unpack	X								
Repack	X								
Clean	X								
b. Bandoleer M7	Inspect		X						
	Unpack		X						
	Repack	X							
	Clean	X							



Maintenance Allocation Chart for Land Mines - Continued

(1) Group Number	(2) Component/Assembly	(3) Maintenance Function	(4) Maintenance Level					(5) Tools and Equipment Ref Code	(6) Remarks Code
			Field			Sustainment			
			Crew	Service	Field	Below Depot	Depot		
			C	O	F	H	D		
0204	c. Test Set	Inspect	X						
		Test	X						
		Unpack	X						
		Repack	X						
		Clean	X						
	d. Firing Device M57	Inspect	X						
		Test	X						
		Unpack	X						
		Repack	X						
		Clean	X						
	e. Adapter	Install	X						
		Inspect	X						
		Test	X						
		Unpack	X						
		Repack	X						
	f. Blasting Cap Assy M10	Clean	X						
		Install	X						
		Inspect	X						
		Test	X						
		Unpack	X						
	g. Packing Material	Repack	X						
		Clean	X						
		Install	X						
		Inspect		X					
		Clean		X					
	a. Mine, APERS, Training: M81	Mark		X					
		Repair		X					
		Replace		X					
Inspect		X							
Test		X							
	Unpack	X							
	Repack	X							
	Clean	X							
	Touchup		X						
	Mark			X					
	Paint			X					
	Repair		X						

Maintenance Allocation Chart for Land Mines - Continued

(1) Group Number	(2) Component/Assembly	(3) Maintenance Function	(4) Maintenance Level					(5) Tools and Equipment Ref Code	(6) Remarks Code	
			Field			Sustainment				
			Crew	Service	Field	Below Depot	Depot			
			C	O	F	H	D			
0300 0301	b. Fuze, Mine, AP, Inert M605	Inspect	X							
		Test	X							
		Unpack	X							
		Repack	X							
		Clean	X							
		Install	X							
		Paint			X					
	c. Spool, Wire	Repair	X							
		Inspect	X							
		Test			X					
		Unpack	X							
		Repack	X							
		Clean	X							
		Install	X							
	d. Wrench M25	Unpack	X							
		Repack	X							
	e. Packing Material	Inspect		X						
		Clean		X						
		Mark		X						
		Repair		X						
		Replace		X						
	0300 0301	Mine, Antitank (Service)	Inspect	X						
			Test					X		
Unpack			X							
a. Mine, AT: M15		Repack	X							
		Clean	X							
		Touchup		X						
		Mark			X					
		Paint			X					
		b. Fuze M603	Inspect	X						
			Test					X		
			Unpack	X						
			Repack	X						
Clean			X							
Install			X							
Replace		X								

Maintenance Allocation Chart for Land Mines - Continued

(1) Group Number	(2) Component/Assembly	(3) Maintenance Function	(4) Maintenance Level					(5) Tools and Equipment Ref Code	(6) Remarks Code
			Field			Sustainment			
			Crew	Service	Field	Below Depot	Depot		
			C	O	F	H	D		
0302	c. Fuze M624	Inspect	X						
		Test					X		
		Unpack	X						
		Repack	X						
		Clean	X						
		Install	X						
		Replace	X						
	d. Activator M2	Inspect	X						
		Test					X		
		Unpack	X						
		Repack	X						
		Clean	X						
		Install	X						
		Paint			X				
	e. Wrench M20	Unpack	X						
		Repack	X						
	f. Packing Material	Inspect		X					
		Clean		X					
		Mark		X					
		Repair		X					
		Replace		X					
	a. Mine, AT: M19	Inspect	X						
		Test					X		
		Unpack	X						
	b. Fuze M606	Repack	X						
		Clean	X						
Touchup			X						
Inspect		X							
Test						X			
c. Detonator M50	Replace	X							
	Inspect	X							
	Test					X			
	Unpack	X							
	Repack	X							
	Clean	X							
	Install	X							

Maintenance Allocation Chart for Land Mines - Continued

(1) Group Number	(2) Component/Assembly	(3) Maintenance Function	(4) Maintenance Level					(5) Tools and Equipment Ref Code	(6) Remarks Code	
			Field			Sustainment				
			Crew	Service	Field	Below Depot	Depot			
			C	O	F	H	D			
0303	d. Activator M2	Inspect	X							
		Test					X			
		Unpack	X							
		Repack	X							
		Clean	X							
		Install	X							
		Replace	X							
	e. Wrench M22	Unpack	X							
		Repack	X							
	f. Packing Material	Inspect		X						
		Clean		X						
		Mark		X						
		Repair		X						
		Replace		X						
	a. Mine, AT: M21	Inspect	X							
		Test						X		
		Unpack	X							
		Repack	X							
		Clean	X							
		Touchup		X						
		Mark			X					
		Paint			X					
		b. Fuze M607	Inspect	X						
			Test						X	
	Unpack		X							
	Repack		X							
	Clean		X							
	Install		X							
c. Booster M120	Inspect	X								
	Test						X			
	Unpack	X								
	Repack	X								
	Clean	X								
	Install	X								
d. Wrench M22	Replace	X								
	Unpack	X								
	Repack	X								

Maintenance Allocation Chart for Land Mines - Continued

(1) Group Number	(2) Component/Assembly	(3) Maintenance Function	(4) Maintenance Level					(5) Tools and Equipment Ref Code	(6) Remarks Code
			Field			Sustainment			
			Crew	Service	Field	Below Depot	Depot		
			C	O	F	H	D		
0304	e. Packing Material	Inspect		X					
		Clean		X					
		Mark		X					
		Repair		X					
		Replace		X					
	a. Mine, OFF Route, AT: M24	Inspect	X						
		Test					X		
		Unpack	X						
		Repack	X						
		Clean	X						
		Touchup		X					
		Mark			X				
		Paint			X				
		b. Rocket 3.5 w/Fuze M404	Inspect	X					
			Test					X	
	Unpack		X						
	Repack		X						
	Clean		X						
	c. M2 Discriminator Wire	Inspect	X						
		Test					X		
		Unpack	X						
		Repack	X						
		Clean	X						
	d. M2 Discriminator Wire	Inspect	X						
		Test	X						
Unpack		X							
Repack		X							
Clean		X							
e. Packing Material	Inspect		X						
	Clean		X						
	Mark		X						
	Repair		X						
	Replace		X						

Maintenance Allocation Chart for Land Mines - Continued

(1) Group Number	(2) Component/Assembly	(3) Maintenance Function	(4) Maintenance Level					(5) Tools and Equipment Ref Code	(6) Remarks Code	
			Field			Sustainment				
			Crew	Service	Field	Below Depot	Depot			
			C	O	F	H	D			
0400 0401	Mines, Antitank, Practice a. Mine, AT, Prac M12A1	Inspect	X							
		Test					X			
		Unpack	X							
		Repack	X							
		Clean	X							
		Touchup		X						
		Mark			X					
		Paint			X					
		b. Fuze, Mine, At Prac: M604	Inspect	X						
			Test						X	
	Unpack		X							
	Repack		X							
	Clean		X							
	Install		X							
	Paint				X					
	Replace		X							
	c. Activator Prac M1		Inspect	X						
			Test						X	
		Unpack	X							
		Repack	X							
		Clean	X							
		Install	X							
		Inspect	X							
		Replace	X							
		d. Firing Device M2	Inspect	X						
			Test						X	
	Unpack		X							
	Repack		X							
	Clean		X							
	Install		X							
	Inspect		X							
	Replace		X							
	e. Wrench M20		Inspect	X						
Test										
Unpack		X								
Repack		X								
Clean		X								
Install		X								
Inspect		X								

Maintenance Allocation Chart for Land Mines - Continued

(1) Group Number	(2) Component/Assembly	(3) Maintenance Function	(4) Maintenance Level					(5) Tools and Equipment Ref Code	(6) Remarks Code
			Field			Sustainment			
			Crew	Service	Field	Below Depot	Depot		
			C	O	F	H	D		
0402	f. Packing Material	Inspect		X					
		Clean		X					
		Mark		X					
		Repair		X					
		Replace		X					
	a. Mine, AT, Prac: M20	Inspect	X						
		Test					X		
		Unpack	X						
		Repack	X						
		Clean	X						
		Touchup		X					
		Mark			X				
	b. Fuze, Mine, At Prac: M604	Inspect	X						
		Test					X		
		Unpack	X						
		Repack	X						
		Clean	X						
		Mark			X				
		Install	X						
		Paint			X				
		Replace	X						
	c. Activator Prac M1	Inspect	X						
		Test					X		
		Unpack	X						
		Repack	X						
		Clean	X						
		Install	X						
		Paint			X				
		Replace	X						
	d. Firing Device M3	Inspect	X						
		Test					X		
		Unpack	X						
		Repack	X						
	Clean	X							
	Install	X							
	Replace	X							
e. Wrench M20	Unpack	X							
	Repack	X							

Maintenance Allocation Chart for Land Mines - Continued

(1) Group Number	(2) Component/Assembly	(3) Maintenance Function	(4) Maintenance Level					(5) Tools and Equipment Ref Code	(6) Remarks Code
			Field			Sustainment			
			Crew	Service	Field	Below Depot	Depot		
			C	O	F	H	D		
0403	f. Packing Material	Inspect		X					
		Clean		X					
		Mark		X					
		Repair		X					
		Replace		X					
	a. Mine, AT, Training: M80	Inspect	X						
		Test					X		
		Unpack	X						
		Repack	X						
		Clean	X						
	b. Fuze, Mine, AT, Prac M605	Touchup		X					
		Mark			X				
		Inspect	X						
		Test					X		
		Unpack	X						
	c. Activator Prac M1	Repack	X						
		Clean	X						
		Mark			X				
		Install	X						
		Paint			X				
	d. Wrench M20	Replace	X						
		Inspect	X						
		Test					X		
		Unpack	X						
		Repack	X						
	e. Packing Material	Clean							
		Install	X						
		Replace	X						
		Inspect		X					
		Replace		X					



Maintenance Allocation Chart for Land Mines - Continued

(1) Group Number	(2) Component/Assembly	(3) Maintenance Function	(4) Maintenance Level					(5) Tools and Equipment Ref Code	(6) Remarks Code
			Field			Sustainment			
			Crew	Service	Field	Below Depot	Depot		
			C	O	F	H	D		
0500	Fuzes, Mine:								
0501	a. Fuze, Mine: Comp, Prac, M10A1	Inspect	X						
		Test					X		
		Unpack	X						
		Repack	X						
		Clean	X						
		Touchup		X					
		Mark			X				
		Install	X						
		Paint			X				
		Repair		X					
		Replace	X						
	b. Primer, Igniter	Inspect	X						
		Test					X		
		Unpack	X						
		Repack	X						
		Clean	X						
		Touchup		X					
		Mark			X				
		Install	X						
		Paint			X				
		Repair					X		
		Replace	X						
	c. Packing Material	Inspect		X					
		Clean		X					
		Mark		X					
		Repair		X					
		Replace		X					
0502	a. Fuze, Mine, AT, M603	Inspect	X						
		Test					X		
		Unpack	X						
		Repack	X						
		Clean	X						
		Touchup		X					
		Mark			X				
		Install	X						
		Paint			X				
		Repair		X					
		Replace	X						

Maintenance Allocation Chart for Land Mines - Continued

(1) Group Number	(2) Component/Assembly	(3) Maintenance Function	(4) Maintenance Level					(5) Tools and Equipment Ref Code	(6) Remarks Code
			Field			Sustainment			
			Crew	Service	Field	Below Depot	Depot		
			C	O	F	H	D		
0503	b. Packing Material	Inspect		X					
		Clean		X					
		Mark		X					
		Repair		X					
		Replace		X					
	a. Fuze, Mine, AT Prac M604	Inspect	X						
		Test					X		
		Unpack	X						
		Repack	X						
		Clean	X						
		Touchup		X					
		Install	X						
		Paint			X				
		Replace	X						
0504	b. Packing Material	Inspect		X					
		Clean		X					
		Mark		X					
		Repair		X					
		Replace		X					
	a. Fuze, Mine-Combo M605	Inspect	X						
		Test					X		
		Unpack	X						
		Repack	X						
		Clean	X						
		Touchup		X					
		Install	X						
		Paint			X				
		Replace	X						
b. Packing Material	Inspect		X						
	Clean		X						
	Mark		X						
	Repair		X						
	Replace		X						

Maintenance Allocation Chart for Land Mines - Continued

(1) Group Number	(2) Component/Assembly	(3) Maintenance Function	(4) Maintenance Level					(5) Tools and Equipment Ref Code	(6) Remarks Code
			Field			Sustainment			
			Crew	Service	Field	Below Depot	Depot		
			C	O	F	H	D		
0505	a. Fuze, Mine: M624	Inspect	X						
		Test					X		
		Unpack	X						
		Repack	X						
		Clean	X						
		Install	X						
		Replace	X						
	b. Packing Material	Inspect		X					
		Clean		X					
		Mark		X					
Repair			X						
Replace			X						
0600	Miscellaneous Components								
0601	a. Activator, AT Mine: Prac, M1	Inspect	X						
		Test					X		
		Unpack	X						
		Repack	X						
		Clean	X						
		Install	X						
		Replace	X						
	b. Packing Material	Inspect		X					
		Clean		X					
		Mark		X					
Repair			X						
Replace			X						
0602	a. Activator, AT, Mine: M2	Inspect	X						
		Test					X		
		Unpack	X						
		Repack	X						
		Clean	X						
		Install	X						
		Replace	X						
	b. Packing Material	Inspect		X					
		Clean		X					
		Mark		X					
Repair			X						
Replace			X						

Maintenance Allocation Chart for Land Mines - Continued

(1) Group Number	(2) Component/Assembly	(3) Maintenance Function	(4) Maintenance Level					(5) Tools and Equipment Ref Code	(6) Remarks Code
			Field			Sustainment			
			Crew	Service	Field	Below Depot	Depot		
			C	O	F	H	D		
0603	a. Arming Plug, AT, Mine: M4 Series	Inspect	X						
		Test					X		
		Unpack	X						
		Repack	X						
		Clean	X						
		Install	X						
		Replace	X						
	b. Packing Material	Inspect		X					
		Clean		X					
		Mark		X					
Repair			X						
Replace			X						
0604	a. Body, AP, Mine: M8A1	Inspect	X						
		Test					X		
		Unpack	X						
		Repack	X						
		Clean	X						
		Install	X						
		Replace	X						
	b. Packing Material	Inspect		X					
		Clean		X					
		Mark		X					
0605	a. Booster, AT Mine: M120	Inspect	X						
		Test					X		
		Unpack	X						
		Repack	X						
		Clean	X						
		Install	X						
		Replace	X						
	b. Packing Material	Inspect		X					
		Clean		X					
		Mark		X					
			X						
			X						

Maintenance Allocation Chart for Land Mines - Continued

(1) Group Number	(2) Component/Assembly	(3) Maintenance Function	(4) Maintenance Level					(5) Tools and Equipment Ref Code	(6) Remarks Code
			Field			Sustainment			
			Crew	Service	Field	Below Depot	Depot		
			C	O	F	H	D		
0606	a. Cap, AP, Mine	Inspect	X						
		Test					X		
		Unpack	X						
		Repack	X						
		Clean	X						
		Install	X						
		Replace	X						
	b. Packing Material	Inspect		X					
		Clean		X					
		Mark		X					
Repair			X						
Replace			X						
0607	a. Charge, Spotting, Mine:	Inspect	X						
		Test					X		
		Unpack	X						
		Repack	X						
		Clean	X						
		Install	X						
		Replace		X					
	b. Packing Material	Inspect		X					
		Clean		X					
		Mark		X					
Repair			X						
Replace			X						
0608	a. Primer, Igniter, Mine Fuze	Inspect	X						
		Test					X		
		Unpack	X						
		Repack	X						
		Clean	X						
		Install	X						
		Replace		X					
	b. Packing Material	Inspect		X					
		Clean		X					
		Mark		X					
Repair			X						
Replace			X						

Maintenance Allocation Chart for Land Mines - Continued

(1) Group Number	(2) Component/Assembly	(3) Maintenance Function	(4) Maintenance Level					(5) Tools and Equipment Ref Code	(6) Remarks Code
			Field			Sustainment			
			Crew	Service	Field	Below Depot	Depot		
			C	O	F	H	D		
0609	a. Retainer, AT Booster	Inspect	X						
		Test					X		
		Unpack	X						
		Repack	X						
		Clean	X						
	b. Packing Material	Install	X						
		Replace		X					
		Inspect		X					
		Clean		X					
		Mark		X					
0610	a. Simulator, AP Projectile, Mine M8	Repair		X					
		Replace		X					
		Inspect	X						
		Test					X		
		Unpack	X						
	b. Packing Material	Repack	X						
		Clean	X						
		Install	X						
		Replace		X					
		Inspect		X					
0700 0701	Mine Canister	Clean		X					
		Touchup		X					
		Mark			X				
		Inspect	X						
		Unpack	X						
	a. Canister, Mine: M87 and M87A1	Repack	X						
		Clean	X						
		Touchup		X					
		Mark			X				
		Inspect	X						
b. Container, Ammunition, PA113	Unpack	X							
	Repack	X							
	Clean	X							
	Touchup		X						
	Mark			X					
0701	a. Canister, Mine: M87 and M87A1	Inspect		X					
		Unpack	X						
		Repack	X						

Maintenance Allocation Chart for Land Mines - Continued

(1) Group Number	(2) Component/Assembly	(3) Maintenance Function	(4) Maintenance Level					(5) Tools and Equipment Ref Code	(6) Remarks Code
			Field			Sustainment			
			Crew	Service	Field	Below Depot	Depot		
			C	O	F	H	D		
0702	c. Packing Material	Inspect		X					
		Clean		X					
		Repair		X					
		Replace		X					
	a. Canister, Mine, Practice: M88	Inspect		X					
		Unpack	X						
		Repack	X						
		Clean	X						
		Touchup		X					
		Mark			X				
	b. Container, Ammunition, PA113	Inspect	X						
		Unpack	X						
		Repack	X						
		Clean	X						
Touchup			X						
Mark				X					
0703	c. Packing Material	Inspect		X					
		Clean		X					
		Repair		X					
		Replace		X					
	a. Canister, Mine, Training: M89	Unpack	X						
		Repack	X						
		Clean	X						
		Touchup		X					
	b. Container, Ammunition, PA113	Mark			X				
		Inspect	X						
		Unpack	X						
		Repack	X						
	c. Packing Material	Clean	X						
		Touchup		X					
Mark				X					
Inspect			X						
Clean			X						
Repair			X						

**Section III. TOOLS AND TEST EQUIPMENT  
FOR  
LAND MINES**

None

**Section IV. REMARKS  
FOR  
LAND MINES**

None



**THIS PAGE INTENTIONALLY LEFT BLANK**

## APPENDIX D

EXPENDABLE AND DURABLE ITEMS LIST

---

## SECTION I. INTRODUCTION

**D-1. SCOPE**

This appendix lists expendable and durable items you will need to operate and maintain the land mine.

These items are authorized to you by CTA 50970, Expendable Items (except Medical, Class V, Repair Parts, and Heraldic items).

**D-2. EXPLANATION OF COLUMNS**

a. Column (1) Item number. This number is assigned to the entry in the listing for referencing when required.

b. Column (2) Level. This column identifies the lowest level of maintenance that requires the listed item.

- 0 - Unit Maintenance
- F - Direct Support Maintenance
- H - General Support Maintenance

c. Column (3) National Stock Number. This is the National Stock Number (NSN) assigned to the item; use it to request or requisition the item.

d. Column (4) Description. Indicates the federal item name and, if required, a description to identify the item. The last line for each item indicates the Commercial and Government Entity Code (CAGEC) parentheses followed by the part number.

e. Column (5) Unit of Measure (U/M)/Unit of Issue (U/I). This column indicates the measure used in performing the actual maintenance function. This measure is expressed by a two-character alphabetical abbreviation (i.e., EA, IN, PR). If the unit of measure differs from the unit of issue, as shown in the Army Master Data File (AMDF), requisition the lowest unit of issue that will satisfy your requirements.

## SECTION II. EXPENDABLE AND DURABLE ITEMS LIST

(1) Item Number	(2) Level	(3) National Stock Number	(4) Description	(5) U/M
1	0	6810-00-184-4796	ACETONE, TECHNICAL: 5 gallon can (81348) 0-A-51	CN
2	0	8040-00-273-8716	ADHESIVE: (81348) MMM-A-121	CN
3	0	6810-00-543-7415	ALCOHOL, DENATURED: Grade III (81348) OE760	GL
4	0	7920-00-900-3577	BRUSH: 3/4 in. x 1-3/8 in. (17987) 15SS	EA
5	0	8020-00-240-6361	BRUSH, ARTISTS: Flat chisel edge (81348) H-B-118	EA
6	0	8020-00-246-8504	BRUSH, ARTISTS: Flat round edge (81348) H-B-118	EA
7	0	7920-00-255-5135	BRUSH, WIRE SCRATCH: Beryllium copper alloy, curved handle, 14 in. x 15/16 in. block, 6 in. x 1-1/4 in. wire brush (81348) HB178	EA
8	0	7920-00-269-0933	BRUSH, WIRE SCRATCH: Beryllium copper alloy, straight handle, 7 in. x 1 in. block, 6 in. x 1-1/4 in. wire brush (81348) HB178	EA
9	0	6850-00-174-9672	CORROSION REMOVING COMPOUND: Liquid, Type II, 1 gal bottle (81349) MILC10578	GL
10	0	7930-00-249-8036	DETERGENT, GENERAL PURPOSE: Powder, 5 lb container (58536) A-A-1376	CO
11	0	8010-00-297-2119	ENAMEL: Blue, No. 35109 (96906) MS35527-3	GL
12	0	8010-00-902-0182	ENAMEL: Forest green, No. 34079 (81348) TT-E-516	CN
13	0	8010-00-297-2116	ENAMEL: Olive drab, No. 34088 (96906) MS35527-10	GL

(1) Item Number	(2) Level	(3) National Stock Number	(4) Description	(5) U/M
14	O	8010-00-848-9272	ENAMEL: Olive drab, No. 34088 (81348) TT-E-516	PT
15	O	5315-00-597-9766	FASTENER CORRUGATED WOOD JOINT: Sawtooth edge 1/2 in. deep, 100 per box (81348) FF-F-133	BX
16	O	7510-00-161-0815	INK, MARKING STENCIL: White No. CN 37875, 1 gallon unit Type 2, weather resistant package (80244) A-A-208	
17	O	7520-00-973-1059	MARKER, TUBE TYPE: Black felt chisel tip, pocket clip provided (81348) GG-M-00114	PK
18	O	5315-00-889-2743	NAIL: Style 4, Type II, size 4, 1-1/2 in. LB (81348) FF-N-105	
19	O	5315-00-889-2744	NAIL: Type II, size 4A 2 in. (81348) FF-N-105	LB
20	O	5350-00-271-7930	PAPER, ABRASIVE: Flint, Class I (81348) P-P-105	PK
21	O	7920-00-205-1711	RAG, WIPING: Cotton, unbleached, mixture, 50 lb bale (58536) A-A-2552	BE
22	O	5340-01-264-2350	SEAL, ANTIPILFERAGE: (19203) 8794342-6	EA
23	O	8135-00-239-5291	SEAL, STRAPPING: 5/8 in. (81348) QQS-766	BX
24	O	8135-00-239-5294	SEAL STRAPPING: 1-1/4 in. (19203) 805417	BX
25	O	6850-00-295-7685	SILICONE, COMPOUND: 1-10 lb. unit package (81349) MIL-S-8660	CN
26	O	6850-00-880-7616	SILICONE, COMPOUND: 1 - 8 oz. unit package (81349) MIL-S8660	TU
27	O	6850-00-664-4959	SILICONE, COMPOUND: G-697 (81349) MIL-C-21567	GL

(1) Item Number	(2) Level	(3) National Stock Number	(4) Description	(5) U/M
28	O	6850-00-702-4297	SILICONE, COMPOUND: G-697, 1 - 8 oz. unit package (81349) MIL-C-21567	TU
29	O	5315-00-664-7035	STAPLE WIRING: Flat hd 7/32 in. w, 5/8 in. lg, 0.72 in thickness copper finish (81348) FF-N-105	HD
30	O	8135-00-209-7959	STRAP: 3/4 in. wide (81348) QQ-S-781	
31	F	8135-00-281-4071	STRAPPING: Steel 5/8 in. wide, 0.020 in. thick (81348) QQ-S-781	COIL
32	O	8135-00-283-0671	STRAPPING: Steel 1-1/4 in. (19203) 945013	COIL
33	O	7510-00-283-0612	TAPE, MASKING: 1 in. wide, Type II (58536) A-A-883	RO
34	O	7510-00-266-6711	TAPE, PRESSURE SENSITIVE ADHESIVE: 3/4 in. (58536) A-A-883	RO
35	O	7510-00-266-6715	TAPE, PRESSURE SENSITIVE ADHESIVE: 2 in. (58536) A-A-1830	RO
36	O	8010-00-160-5794	THINNER, PAINT PRODUCTS: (81318) TT-T-306	GL
37	O	5350-00-242-4405	WOOL, METALLIC: Steel, Type I, 1 lb. LB roll (59536) A-A-1043	

**APPENDIX E  
PACKING, MARKING, AND STORAGE DATA**

**Section I. INTRODUCTION**

**E-1. Scope**

This appendix contains information required by organizational level of maintenance for repacking of land mines.

**E-2. Explanation of Columns**

- a. *Item.* Column 1 indicates the nomenclature of the munition.
- b. *Outer Pack.* Column 2 indicates the type of package.
- c. *Inner Pack.* Column 3 indicates the type of pack.
- d. *Number of Items in Package.* Column 4 indicates the quantity of munitions in the outer pack.

e. *Number of Items per Inner Pack.* Column 5 indicates the quantity of munitions in the inner pack.

f. *Total Weight (lbs).* Column 6 indicates total weight of the outer and inner pack and contents.

g. *Total Explosives Weight (lbs).* Column 7 indicates the total weight of explosives of the packaged munitions.

h. *Cube.* Column 8 indicates result of the length, multiplied by the width, multiplied by height of the outer pack.

i. *Field Storage Compatibility.* Column 9 indicates the primary groups into which ammunition is segregated for storage in the field.

**Section II. PACKING, MARKING, AND STORAGE DATA**

(1)  Item	(2)  Outer pack	(3)  Inner pack	(4)  No. items in package	(5) No. items per inner pack	(6) <sup>1</sup> Total weight (lbs)	(7) <sup>1</sup> Total explosive weight (ft)	(8) Cube category	(9) <sup>2</sup> Field storage
MINE, ANTIPERSONNEL, NM: M14, W/INTEGRAL FUZE	Wood box	Fiber carton.	90	90				
Detonator M46	Barrier bag			90	48	5.6	1.8	E
Wrench M22				9				
MINE, ANTIPERSONNEL: M16 SERIES, W/FUZE, MINE: COMBINATION M605	Wirebound box	Metal container	4	4				
Fuze M605	Fiber box			4	39	5.4	0.72	E
Spool Assembly	Barrier bag			2				
Wrench M25				1				

Section II. PACKING, MARKING, AND STORAGE DATA - Continued

(1) Item	(2) Outer pack	(3) Inner pack	(4) No. items in package	(5) No. items per inner pack	(6) <sup>1</sup> Total weight (lbs)	(7) <sup>1</sup> Total explosive weight (ft)	(8) Cube category	(9) <sup>2</sup> Field storage
MINE, ANTIPERSONNEL: M18A1, W/ACCESSORIES								
Bandoleer M7	Wirebound box	Fiberboard box	6	6				
Test Set M40		Barrier bag		1	53.0	9.0	1.2	E
Firing Device M57				6				
Blasting Cap Assembly M4				6				
Identification Tag				6				
Bandoleer M7	Wirebound box	Fiberboard box	6	6				
Blasting Cap Assembly M4		Barrier bag		6	47.0	9.0	1.2	E
				6				
MINE, ANTIPERSONNEL: M26, HE, W/INTEGRAL FUZE	Wood box	Fiber container	18	18	60.0	6.75	1.5	E
MINE, ANTIPERSONNEL: M86	Wirebound box	Shipping & Storage metal container	24	12	50	1.16	1.3	D
SHIPPING & STORAGE METAL CONTAINER PA19			2					
BANDOLEER			12	6				
MINE, ANTIPERSONNEL, PRACTICE: M8/M8A1 AND FUZE, MINE COMBINATION: M10, M10A1, M10OA2			2	2				
Fuze	Wood box	Metal container		2				
Tube Assemblies		Fiber cartons		20				
Igniter Assemblies		Barrier bag		20				
Spotting Charges				20	37.0	0.6	1.3	E
Mine Caps				20				
				20				
MINE, ANTIPERSONNEL, PRACTICE: NM: M68 W/ACCESSORIES								
Bandoleer M7	Wirebound box	Fiberboard box	6	6				

## Section II. PACKING, MARKING, AND STORAGE DATA - Continued

(1) Item	(2) Outer pack	(3) Inner pack	(4) No. items in package	(5) No. items per inner pack	(6) <sup>1</sup> Total weight (lbs)	(7) <sup>1</sup> Total explosive weight (ft)	(8) Cube category	(9) <sup>2</sup> Field storage
Test Set M40		Barrier bag		6				
Firing Device M57				6	52.0	0	1.2	E
Blasting Cap Assembly M10				6				
MINE, ANTITANK, HE, HEAVY, M15, W/FUZE MINE, AT, M603	Wood box	Metal container	1	1				
Fuze M603				1	45.0	22.75	1.17	E
Activator M1				1				
Wrench M20				1				
Fuze, Mine: M624	Wood box	Metal container	12	3	4.2	10.8 g	1.0	E
Shipping and Storage Container: M19A1			4					
Fiber Container			12	3				
MINE, ANTITANK: HE, NM, M19, W/FUZE, MINE AT, M606	Wirebound box	Plastic box Barrier bag	4	4				
Detonator Holder Assembly M50				4	124.5	85	3.9	E
Activator M2				4				
Wrench M22				2				
MINE, ANTITANK: HE, HEAVY, M21, W/FUZE, MINE, AT, M607	Wirebound box	Wood container	4	4				
Fuze M607		Wood support		4	90.0	42	N/A	E
Booster M120		Barrier bag			4			
Wrench M26				2				
MINE, ANTITANK: HE, M24, W/FUZE M404	Wirebound box	Fiber box	2	2	54.5	3.76	2.7	E
MINE, ANTITANK PRACTICE: HEAVY, M12A1, W/FUZE M604 (fuze shipped separately)	Wood box	N/A	2	2	35.0	N/A	1.6	E
MINE, ANTITANK PRACTICE: HEAVY, M20, W/FUZE M604 (fuze shipped separately)	Wood box	N/A	3	3	50.0	N/A	2.9	E



## Section II. PACKING, MARKING, AND STORAGE DATA - Continued

(1) Item	(2) Outer pack	(3) Inner pack	(4) No. items in package	(5) No. items per inner pack	(6) <sup>1</sup> Total weight (lbs)	(7) <sup>1</sup> Total explosive weight (ft)	(8) Cube category	(9) <sup>2</sup> Field storage
Wrench M20				1				
FUZE, MINE COMBINATION ANTIPERSONNEL: M605	Wood box	Metal container	240	4	128	0.73	1.9	E
FUZE, MINE COMBINATION ANTIPERSONNEL: practice M10A1 w/o primer-igniter	Wood box	Fiberboard carton Barrier bag	180	10	66.0	N/A	2.4	E
FUZE, MINE, AT, M603	Wood box	Metal container	144	1	45.0	0.18	1.9	E
FUZE, MINE, AT, M607	Wood box	Fiberboard carton Barrier bag	100	100	82.0	0.11	3.3	E
FUZE, MINE AT: practice M604	Wood box	Metal container	180	1	62.0	6.8	1.9	E
ACTIVATOR, ANTITANK MINE: M2	Wood box	Metal container	180	1	54.5	1.3	2.30	E
ARMING PLUG, ANTI-TANK MINE: M4	Wood box	N/A	128	N/A	66.2	N/A	1.32	E
BOOSTER, ANTITANK MINE: M120	Wood box	Fiberboard carton Barrier bag	1200	200	63.0	29.5	1.7	E
RETAINER, ANTITANK MINE: M120 booster	Fiberboard drum	N/A	25,000	N/A	100	N/A	0.03	E
ACTIVATOR, ANTITANK MINE: practice M1	Wood box	Metal container	180	1	54.5	0.6	2.30	E
BODY MINE: for practice Apers Mine M8A1	Packed as required					N/A		E
CAP, MINE: for practice Apers Mine M8	Packed as required					N/A		E
CHARGE, SPOTTING, MINE: for practice Apers Mine M8	Wood box	Paperboard box Barrier bag	6000	60	55	14	2.4	E
PRIMER-IGINITER, MINE FUZE: for fuze mine combination M10A1 for practice Apers Mine M8	Wood box	Paperboard box Barrier bag	720	20	64.0	0.51	2.4	E
SIMULATOR, MINE, PROJECTILE: for practice Apers Mine M8	Packed as required							E

**Section II. PACKING, MARKING, AND STORAGE DATA - Continued**

(1) Item	(2) Outer pack	(3) Inner pack	(4) No. items in package	(5) No. items per inner pack	(6) <sup>1</sup> Total weight (lbs)	(7) <sup>1</sup> Total explosive weight (lbs)	(8) Cube (ft)	(9) <sup>2</sup> Field storage category
CANISTER, MINE: M87	N/A	Ammuniton container	40	2	1875	303.5	37.6	
CANISTER, MINE, PRACTICE: M88	N/A	Ammuniton container	40	2	1875	0.5	37.6	
CANISTER, MINE, TRAINING: M89	N/A	Ammuniton container	40	2	1900	N/A	37.6	
CANISTER, MINE: M87A1	N/A	Ammuniton container	40	2	1875	323.5	37.6	

## Footnotes:

<sup>1</sup>values are nominal.<sup>2</sup>Refer to paragraph 5-5.

THIS PAGE INTENTIONALLY LEFT BLANK

By Order of the Secretary of the Army:

Official:

YVONNE M. HARRISON  
Administrative Assistant to the  
Secretary of the Army  
00903

DENNIS J. REIMER  
General, United States Army  
Chief of Staff

Official:

Distribution:

To be distributed in accordance with DA Form 12-40E, Block 0950, requirements for TM 9-1345-203-12.

<b>RECOMMENDED CHANGES TO PUBLICATIONS AND BLANK FORMS</b> For use of this form, see AR 25-30; the proponent agency is ODISC4.						Use Part II ( <i>reverse</i> ) for Repair Parts and Special Tool Lists (RPSTL) and Supply Catalogs/Supply Manuals (SC/SM).	DATE
TO: ( <i>Forward to proponent of publication or form</i> ) ( <i>Include ZIP Code</i> )						FROM: ( <i>Activity and location</i> ) ( <i>Include ZIP Code</i> )	
<b>PART I - ALL PUBLICATIONS (EXCEPT RPSTL AND SC/SM) AND BLANK FORMS</b>							
PUBLICATION/FORM NUMBER <b>TM 9-1375-225-12</b>						DATE <b>18 Jun 99</b>	TITLE <b>SOF Demo Kit, M303</b>
ITEM NO.	PAGE NO.	PARA-GRAPH	LINE NO.*	FIGURE NO.	TABLE NO.	RECOMMENDED CHANGES AND REASON <i>(Provide exact wording of recommended changes, if possible).</i>	
1	1-2	1.2.4				Change "Rock Island, IL 61201" to read "Aberdeen Proving Ground, MD 21010". Reason: Wrong Address.	
2	2-3			2-6		Add "LOCKWASHER" to the illustration. Reason: Missing from illustration.	
<i>* Reference to line numbers within the paragraph or subparagraph.</i>							
TYPED NAME, GRADE OR TITLE						TELEPHONE EXCHANGE/AUTOVON, PLUS EXTENSION	SIGNATURE

SAMPLE

**This Page Intentionally Left Blank**

<b>RECOMMENDED CHANGES TO PUBLICATIONS AND BLANK FORMS</b> <small>For use of this form, see AR 25-30; the proponent agency is ODISC4.</small>						<small>Use Part II (reverse) for Repair Parts and Special Tool Lists (RPSTL) and Supply Catalogs/Supply Manuals (SC/SM).</small>	<small>DATE</small>
<small>TO: (Forward to proponent of publication or form) (Include ZIP Code)</small> <b>LRED (AMSRD-AAR-AIL-LS)</b> <b>U.S. Army RDECOM, ARDEC</b> <b>Picatinny Arsenal, NJ 07806-5000</b>						<small>FROM: (Activity and location) (Include ZIP Code)</small>	
<b>PART I - ALL PUBLICATIONS (EXCEPT RPSTL AND SC/SM) AND BLANK FORMS</b>							
<small>PUBLICATION/FORM NUMBER</small> <b>TM 9-1345-203-12</b>						<small>DATE</small> <b>30 Oct 1995</b>	<small>TITLE</small> <b>Operator's and Unit Maintenance Manual for Land Mines</b>
<small>ITEM NO.</small>	<small>PAGE NO.</small>	<small>PARA-GRAPH</small>	<small>LINE NO.*</small>	<small>FIGURE NO.</small>	<small>TABLE NO.</small>	<small>RECOMMENDED CHANGES AND REASON</small> <i>(Provide exact wording of recommended changes, if possible).</i>	
<small>* Reference to line numbers within the paragraph or subparagraph.</small>							
<small>TYPED NAME, GRADE OR TITLE</small>				<small>TELEPHONE EXCHANGE/AUTOVON, PLUS EXTENSION</small>		<small>SIGNATURE</small>	

<b>TO:</b> <i>(Forward direct to addressee listed in publication)</i> <b>LRED (AMSRD-AAR-AIL-LS)</b> <b>U.S. Army RDECOM, ARDEC</b> <b>Picatinny Arsenal, NJ 07806-5000</b>	<b>FROM:</b> <i>(Activity and location) (Include ZIP Code)</i>	<b>DATE</b>
--	--	-------------

**PART II - REPAIR PARTS AND SPECIAL TOOL LISTS AND SUPPLY CATALOGS/SUPPLY MANUALS**

PUBLICATION NUMBER			DATE	TITLE				
PAGE NO.	COLM NO.	LINE NO.	NATIONAL STOCK NUMBER	REFERENCE NO.	FIGURE NO.	ITEM NO.	TOTAL NO. OF MAJOR ITEMS SUPPORTED	RECOMMENDED ACTION

**PART III - REMARKS** *(Any general remarks or recommendations, or suggestions for improvement of publications and blank forms. Additional blank sheets may be used if more space is needed.)*

TYPED NAME, GRADE OR TITLE	TELEPHONE EXCHANGE/AUTOVON, PLUS EXTENSION	SIGNATURE
----------------------------	--	-----------



**PIN: 074148-000**